



ARGÖN

A large circular diagram showing various components of a vinyl pool, including rectangular panels, triangular panels, and a central panel with an upward-pointing triangle. A thick black horizontal bar with rounded ends is overlaid across the middle of the diagram.

VINYL POOLS

ULTRA COMPACT NICHE LIGHT

INSTALLATION & OWNER'S MANUAL

CONTENTS

READ THIS FIRST	3
TOOLS REQUIRED	4
PRODUCT SUPPORT AND INFORMATION	4
INCLUDED PARTS	5
FINISHED INSTALLATION	6
INSTALLATION PROCEDURE	7
LIGHT ASSEMBLY	11
WINTERIZATION	14
KEY DIMENSIONS	17
TROUBLESHOOTING	18
ELECTRICAL GROUNDING / FCC COMPLIANCE	19



NOTICE

**FRESH WATER USE ONLY
HORIZONTAL MOUNT ONLY
NOT INTENDED FOR OPERATION OUT OF WATER**

FOR SUPPLY CONNECTION, USE ONLY AN ISOLATING LOW VOLTAGE POWER SUPPLY WITH UNGROUNDED OUTPUT, EVALUATED FOR SWIMMING POOL USE

READ THIS FIRST

Congratulations on your purchase of the **ARGON** underwater lighting system. All **ARGON** lights are manufactured by Spa Electrics in Australia from only the highest quality materials. For more information about Spa Electrics & our products, please visit www.spaelectrics.com

BEFORE YOU START:

- Cables can be shortened to suit individual installation requirements. Spa Electrics recommends all cabling is protected by conduit and that a junction box (or similar) is incorporated into pool cabling design to avoid siphoning.
- Ensure that the lighting system is installed by a qualified person (e.g. registered pool builder and/or licensed electrician), in accordance with local, state and national regulations.
- For safe and proper installation, ensure that only those parts supplied with the system are used.
- Maximum installation depth for the **ARGON** light is 20" below water line (to top of light).
- The **ARGON** light must be correctly installed in or on the wall of the pool with the top of the lens no less than 4" below the nominal water level.
- All lights should be mounted in a location that is easily accessible without the need for entering or lowering the pool water.
- 35" of cable has been supplied pre-assembled within niche assembly, and must remain stored within the Niche to ensure the light can be accessed above the waterline. [Maximum cable within niche = 47.25" (18AWG). See Page 16 for more information].

CLEANING

- Only use warm water and a soft brush or cloth to clean **ARGON** lights.
DO NOT use detergents or spirits as this can damage the light and void your warranty.

USE OF PRODUCT

- **DO NOT** operate light unless completely submerged in water.
- Operating the light for at least 15 minutes every week is advised (unless removed and stored safely for winter months).
- **ARGON** lights are suited for both domestic and commercial installations and can be operated continuously (24/7) if required.
- Temperature range for installation, operation and servicing: +32°F ~ +104°F (0°C ~ +40°C)



IMPORTANT NOTE

The ARGON light must only be used with a UL 12v AC listed Isolating Low Voltage power source intended for swimming pool use (not included).

Minimum power source wattage requirement - 15 Watts per light.

- DO NOT use electronic or switch-mode power supplies with ARGON lights. These power supplies will damage the light and void your product warranty.
- Pool chemicals & pH levels: Due to the corrosive nature of unbalanced pool chemicals, Spa Electrics strongly recommend that your pool water is balanced prior to installing your pool lights or any plastic or stainless steel components, and tested weekly to maintain these levels. pH levels should be maintained between 7.2 – 7.6 at all times to ensure the longevity of these components.
 - > Failure to do so can result in chemical damage to the light housing and pool fittings, including stainless steel components.
 - > Please note: Lights or components found to have excessive chemical damage will not be covered under our manufacturer's warranty policy.
- This light contains no user-serviceable parts; opening the light will void the product warranty.

TOOLS REQUIRED

- 3" Hole saw
- Box cutter / knife
- No. 2 Phillips screwdriver
- Flat-blade screw driver (for light-head removal)



IMPORTANT NOTES

- The use of power tools during installation is **not** recommended as these devices can cause faults and damage to light components.
- All installation steps should be carried out with manual tools only.
- The enclosed images are for illustrative purposes only. Appearances of parts and assemblies may vary from the enclosed illustrations.
- Please contact your reseller if you have any questions regarding the correct installation of this product.



WINTERIZATION

- Lights must be removed from pool wall and cable disconnected via plug connection & stored in a safe place.
- Winterization Cover must be fitted to Plug Top prior to reinstalling into niche for winter.
- Unless niche/conduit connection is adequately sealed (i.e. via included cable gland components), pool water level must be drained down 12" below the lowest light(s) position in pool wall.
- All conduits should be checked for accumulated water and drained if required.
- Follow instructions on page 14 OR consult your local pool professional for complete pool winterization process.

PRODUCT SUPPORT & INFORMATION

For the most up to date installation information and contact information for assistance in your region, please visit www.spaelectrics.com

INCLUDED PARTS

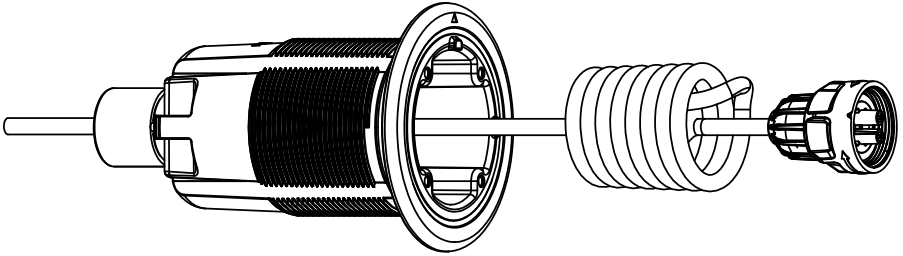

NICHE ASSEMBLY

CABLE

PLUG

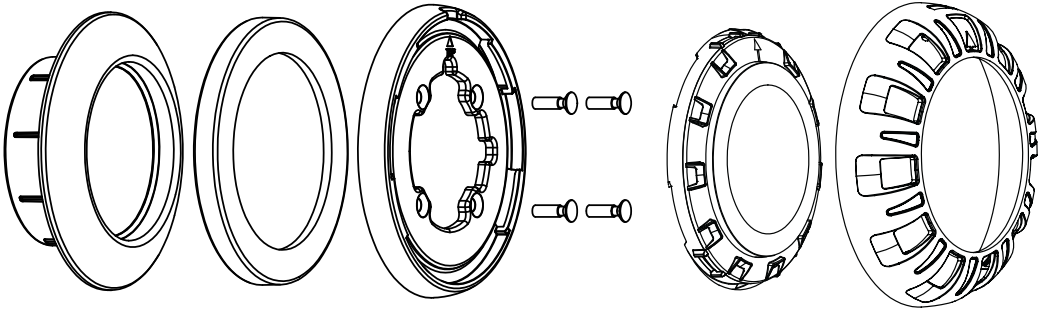

CONICAL
NUT

CONICAL
WASHER

CLAMP
RING

x 4
SCREWS

LIGHT
ASSEMBLY

LIGHT
RIM



1x WARRANTY CARD



1x INSTALLATION MANUAL

Also included is a Winterization Cover if required for seasonal upkeep. Winterization Cover can also be used as Construction Cap.



WINTERIZATION COVER

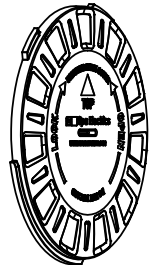

REQUIRED PART (NOT INCLUDED)

UL LISTED ISOLATING LOW VOLTAGE POWER SOURCE INTENDED FOR SWIMMING POOL USE.

Minimum power source wattage requirement - 15 Watts per light

Spa Electrics recommends "LVX" safety transformers (LVX 50 & LVX 100) for use with ARGON 3" lights

FINISHED INSTALLATION

STANDARD WALL MOUNTING

Depending on your installation requirements, conduits may run to a common junction box or return directly to the power supply. In either case, it is imperative that the conduit extends above the water level of the pool at some point in order to prevent siphoning.

NOTE: Conduit should contain a draw-wire to allow easy installation of power cable.

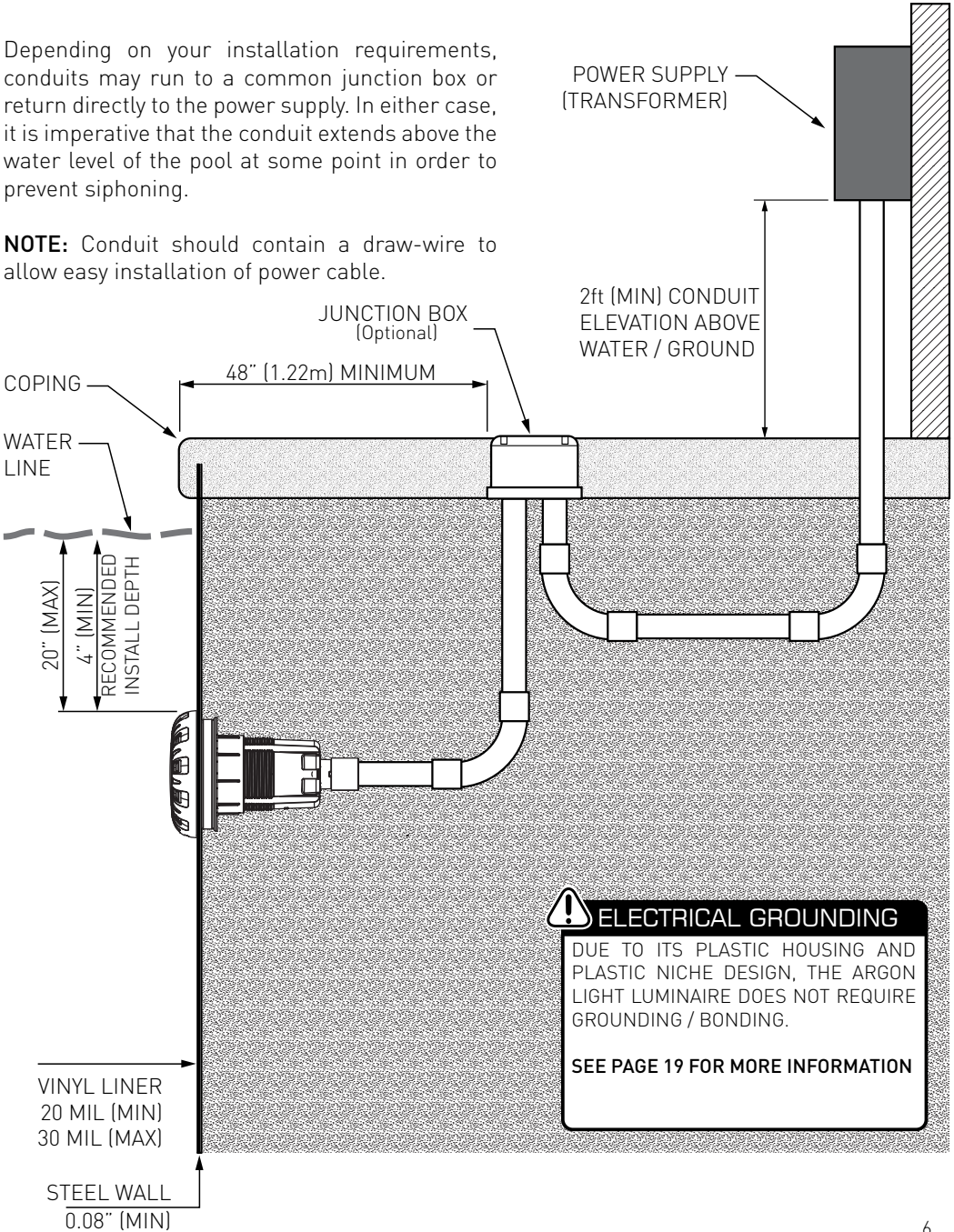

⚠ ELECTRICAL GROUNDING
DUE TO ITS PLASTIC HOUSING AND PLASTIC NICHE DESIGN, THE ARGON LIGHT LUMINAIRE DOES NOT REQUIRE GROUNDING / BONDING.
SEE PAGE 19 FOR MORE INFORMATION

INSTALLATION PROCEDURE

1 MOUNTING HOLE PREPARATION *

* MAY NOT BE REQUIRED IF PRE-PUNCHED / DRILLED HOLES AVAILABLE FOR LIGHT MOUNTING

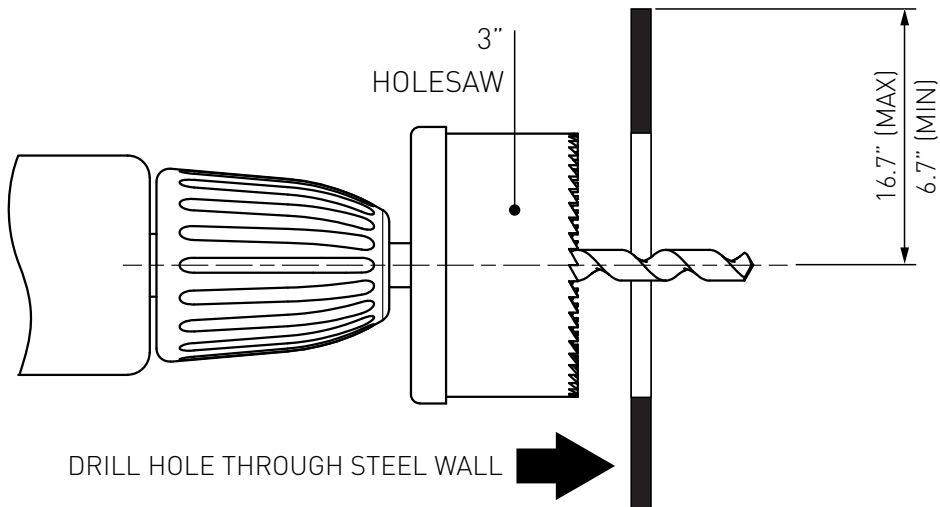

2 ORIENTATION OF NICHE "TOP"

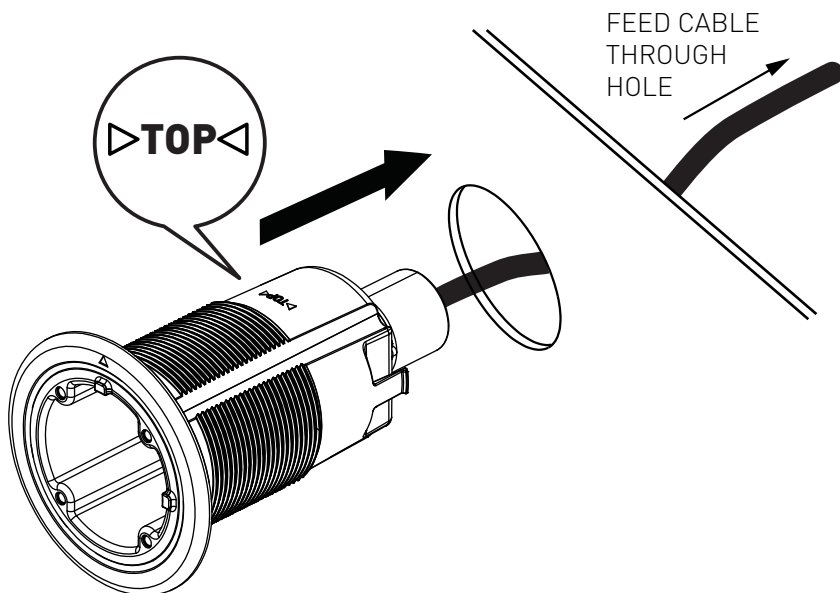

3

ASSEMBLE WASHER AND NUT

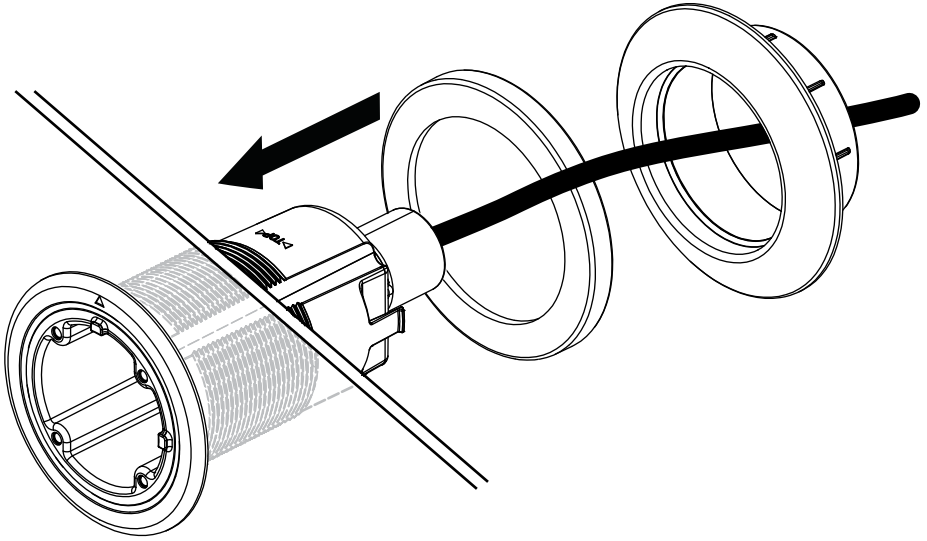

4

TIGHTEN NUT

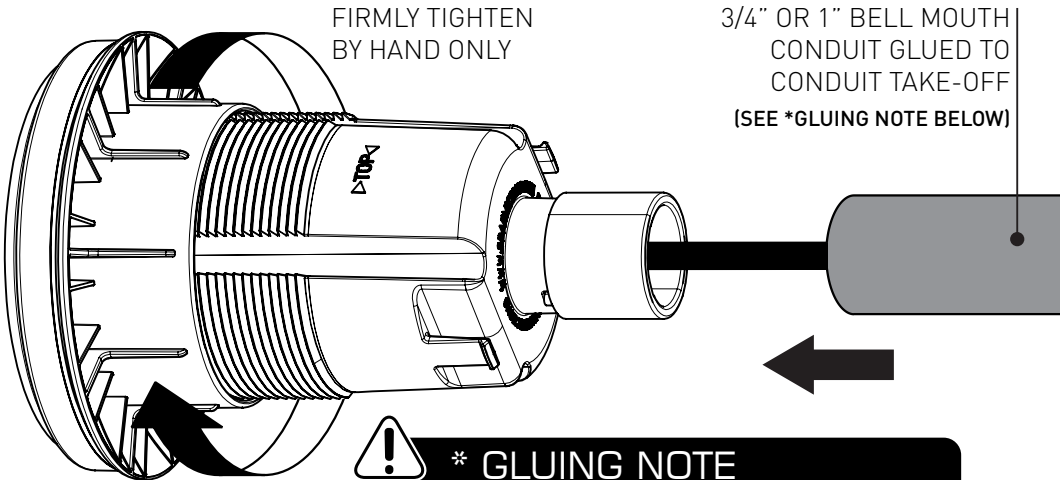

FIRMLY TIGHTEN
BY HAND ONLY

3/4" OR 1" BELL MOUTH
CONDUIT GLUED TO
CONDUIT TAKE-OFF
(SEE *GLUING NOTE BELOW)



* GLUING NOTE

ENSURE P.V.C. SOLVENT CEMENT IS SUITABLE
FOR NON-PRESSURE APPLICATIONS AND USE
WITH A.B.S. PLASTIC

5 AFTER VINYL IS INSTALLED - LOCATE THE LUGS ON FRONT

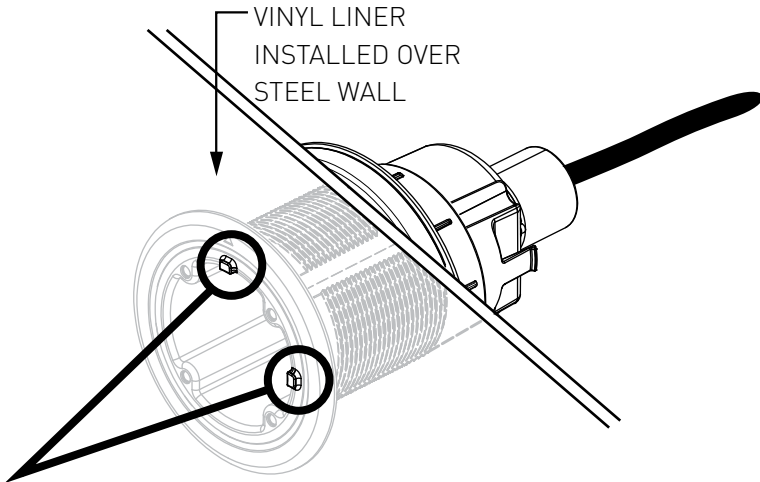

LOCATE THE TWO LUGS BY TOUCH THROUGH THE VINYL MATERIAL
- ONE AT 12 O'CLOCK UNDER THE TOP ARROW
- THE OTHER AT 3 O'CLOCK

6 LINE UP THE LUGS TO THE VINYL CLAMP RING

LOCATE THE
TWO LUG NOTCHES
ON THE CLAMP RING

LINE UP THE
LUG NOTCHES
WITH THE LUGS

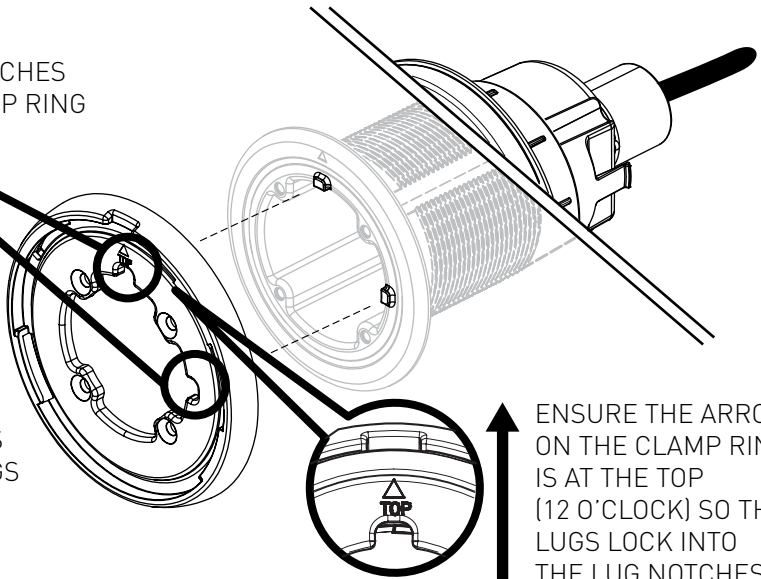

7

FASTEN THE VINYL CLAMP RING

FIRMLY TIGHTEN
FASTENERS MANUALLY
IN NUMBERED ORDER *

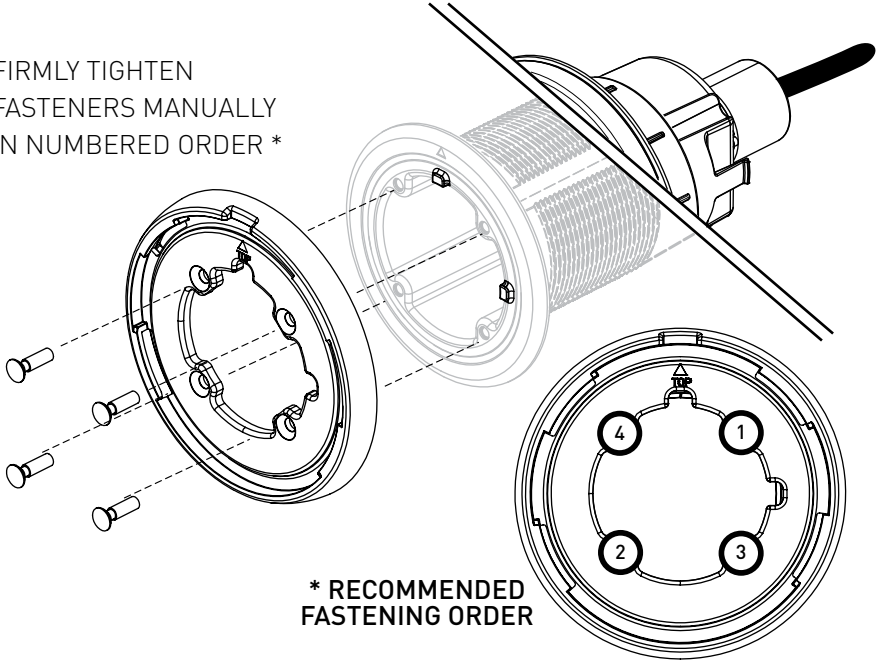

8

TRIM VINYL

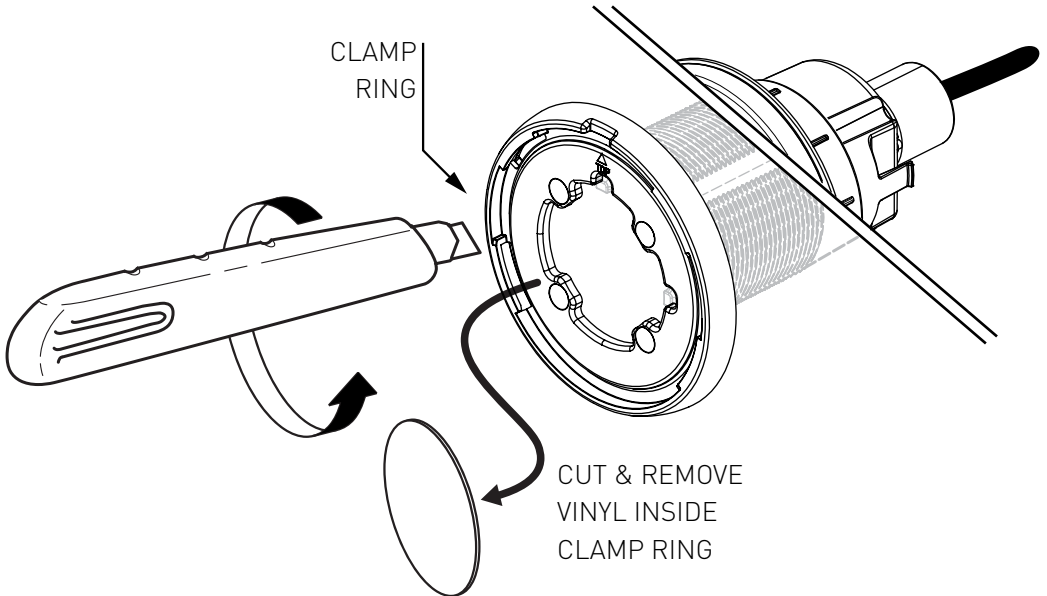

LIGHT ASSEMBLY

1 PULL OUT PLUG AND A SMALL AMOUNT OF CABLE

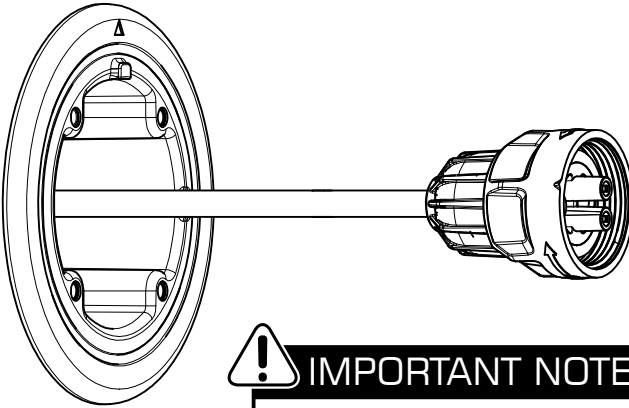

IMPORTANT NOTES

- DO NOT ADD SEALANTS, GREASES OR ADHESIVES
- ENSURE ALL SURFACES ARE CLEAN AND DRY
- **DO NOT ASSEMBLE UNDERWATER**

2 CONNECT THE TERMINALS

ALIGN THE TERMINAL PINS ON PLUG AND BACK OF LIGHT ASSEMBLY AND FIRMLY CONNECT TOGETHER

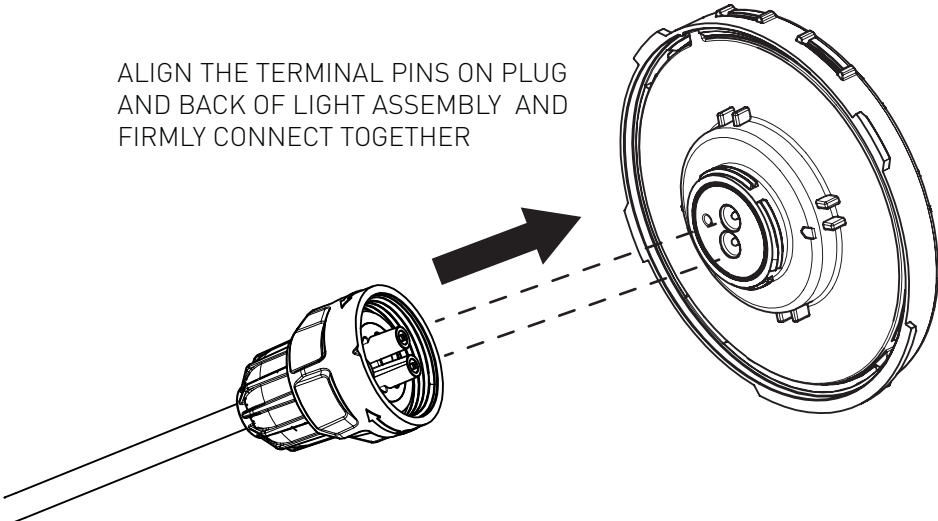

3

FASTEN PLUG TO LIGHT

TO LOCK INTO PLACE:
TWIST COLLAR CLOCKWISE
A FEW TIMES UNTIL
IT'S HAND TIGHT

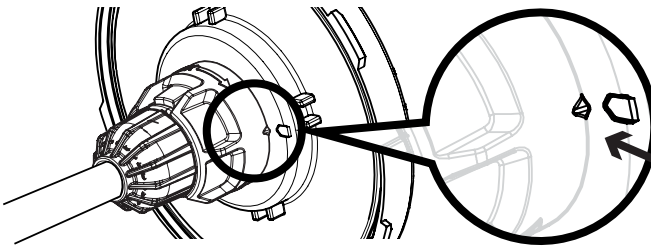
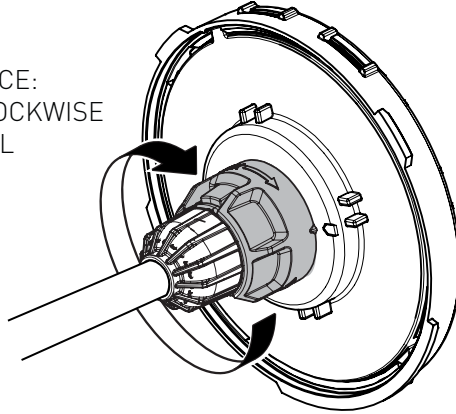

! IMPORTANT
ENSURE THE COLLAR
MARKER STOPS AT OR
PAST THE ALIGNMENT
MARKER ON THE
LIGHT HOUSING

4

COIL CABLE INSIDE NICHE

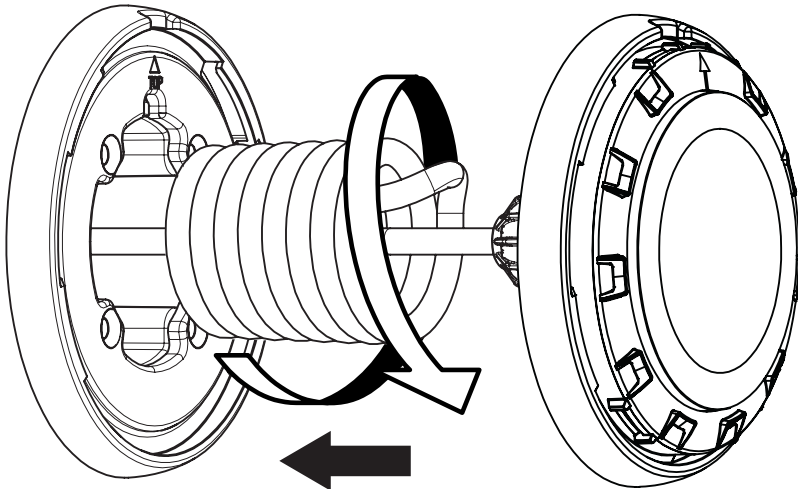

5

TWIST ON THE LIGHT ASSEMBLY TO CLAMP RING

1 PLACE THE LIGHT ASSEMBLY OVER THE CLAMP RING AT 10 O'CLOCK ...

2 ... AND THEN TWIST CLOCKWISE TO 12 O'CLOCK

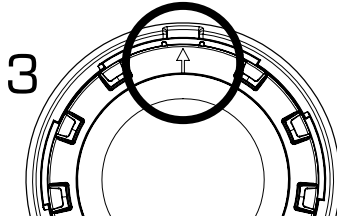
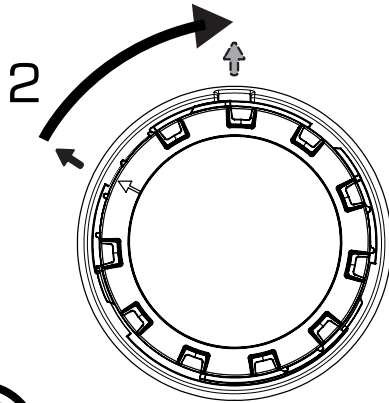
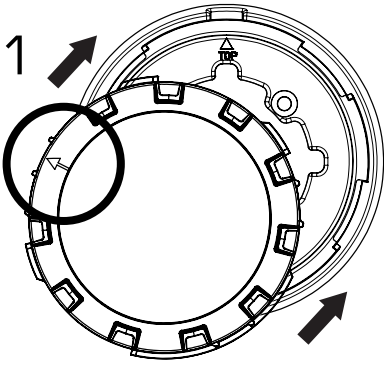

3 ENSURE THE 12 O'CLOCK MARKER ON THE CLAMP RING LINES UP WITH THE 12 O'CLOCK MARKER ON THE LIGHT ASSEMBLY

6

CONNECT ON LIGHT RIM

1 LINE UP BASE OF LIGHT RIM WITH BASE OF LIGHT ASSEMBLY (NOTE LOCK-IN TABS AT BASE OF INSIDE OF LIGHT RIM)

2 CLICK ON AND PUSH IN AT TOP

3 ENSURE LIGHT RIM CLICKS INTO PLACE

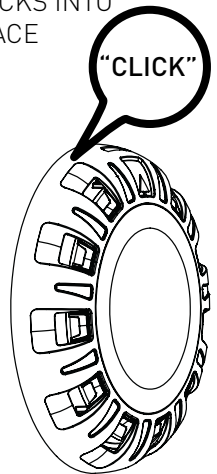
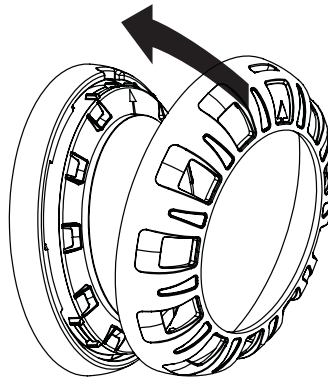
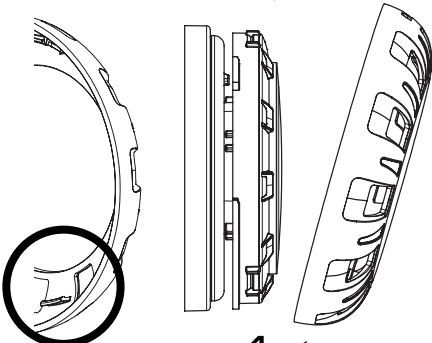

TWO LOCK-IN TABS AT BASE

WINTERIZATION

LIGHT REMOVAL

1 PUSH AND LEVER OFF LIGHT RIM WITH FLAT BLADE

INSERT FLAT BLADE SCREWDRIVER INTO NICHE ABOVE TOP 12 O'CLOCK ARROW AND LEVER OFF LIGHT RIM

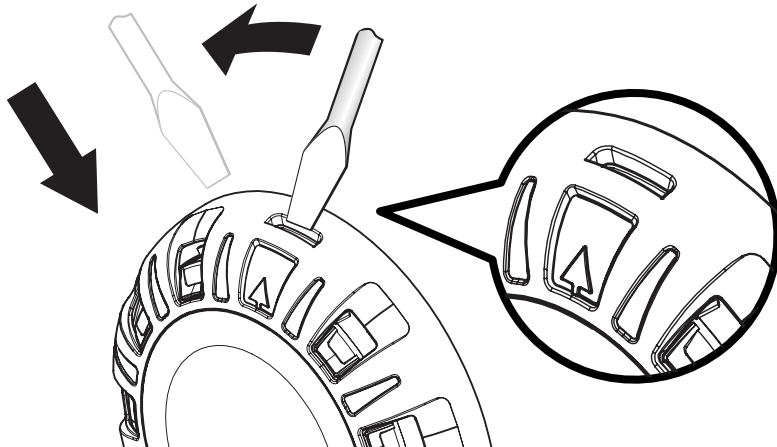

2 ROTATE AND PULL OUT LIGHT ASSEMBLY

ROTATE LIGHT ASSEMBLY COUNTER-CLOCKWISE SO THE ARROW ON THE LIGHT ASSEMBLY IS AT 10 O'CLOCK AND THEN PULL OUT THE LIGHT ASSEMBLY FROM NICHE

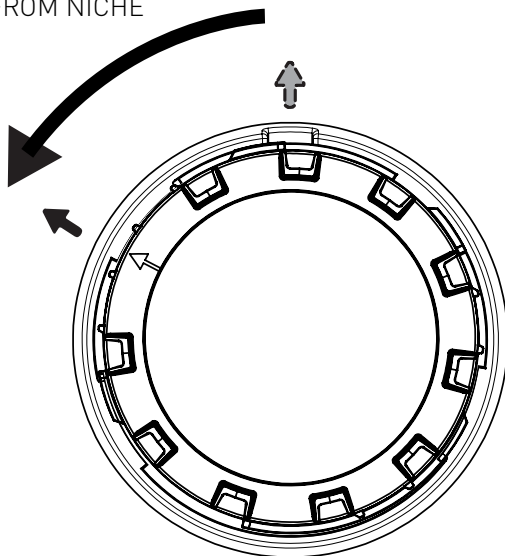

WINTERIZATION

LIGHT REMOVAL

3 REMOVE PLUG FROM LIGHT

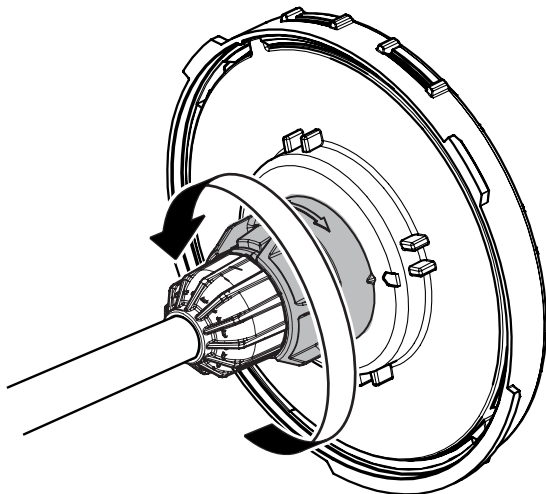

UNSCREW PLUG COLLAR
COUNTER-CLOCKWISE
UNTIL IT IS FREE SPINNING

4 DISCONNECT THE TERMINALS

DISCONNECT LIGHT ASSEMBLY
FROM PLUG BY PULLING APART

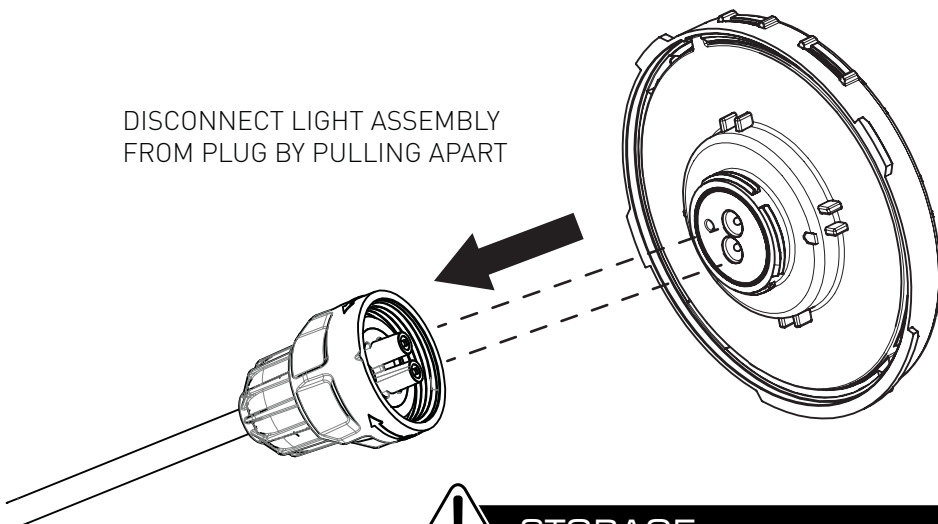

STORAGE

ENSURE LIGHT ASSEMBLY AND LIGHT RIM
IS SAFELY STORED FOR NEXT SEASON USE

WINTERIZATION

WINTERIZATION COVER ATTACHMENT

5 CONNECT WINTERIZATION COVER

- 1 ALIGN TERMINAL PINS ON PLUG WITH TERMINAL PINS ON BACK OF WINTERIZATION COVER AND FIRMLY ASSEMBLE PLUG TO COVER

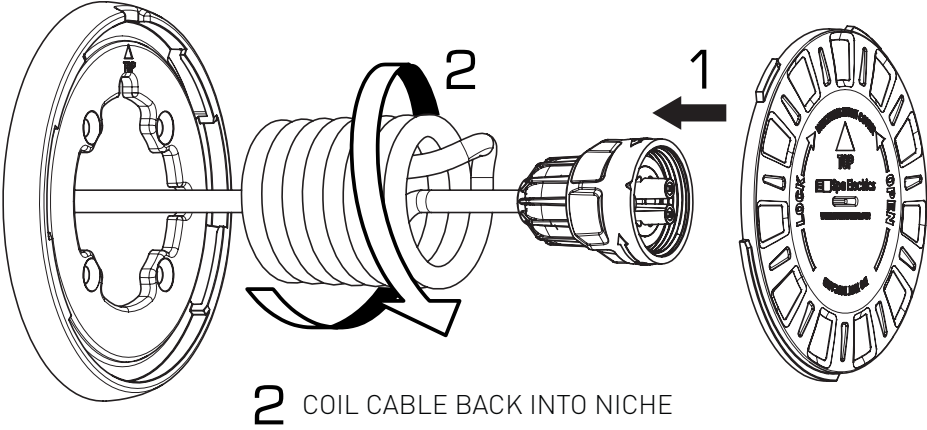

6 LOCK ON WINTERIZATION COVER

- PLACE WINTERIZATION COVER ONTO CLAMP RING AT 10 O'CLOCK AND TURN CLOCKWISE TO 12 O'CLOCK TO LOCK INTO PLACE

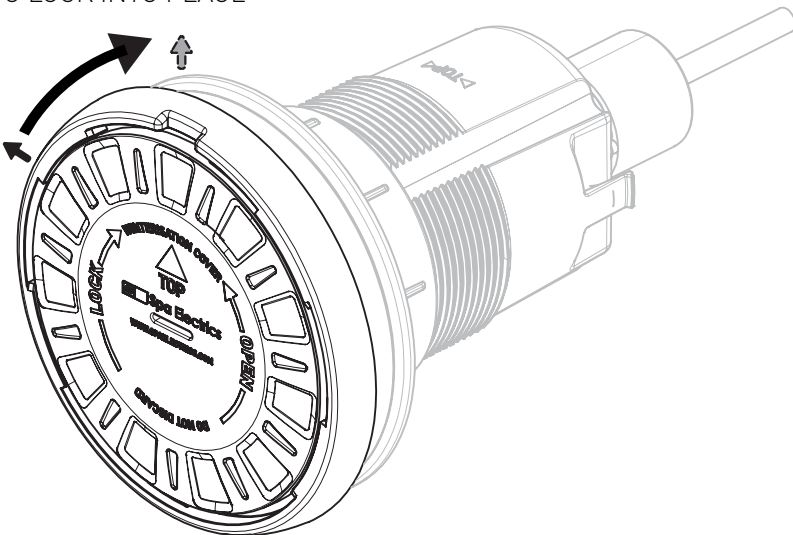

KEY DIMENSIONS

A NICHE

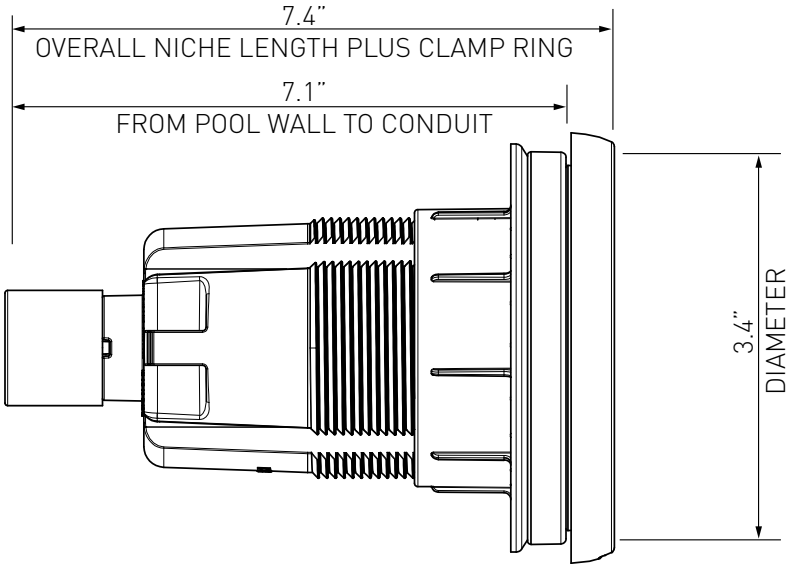

B INSTALLED LIGHT

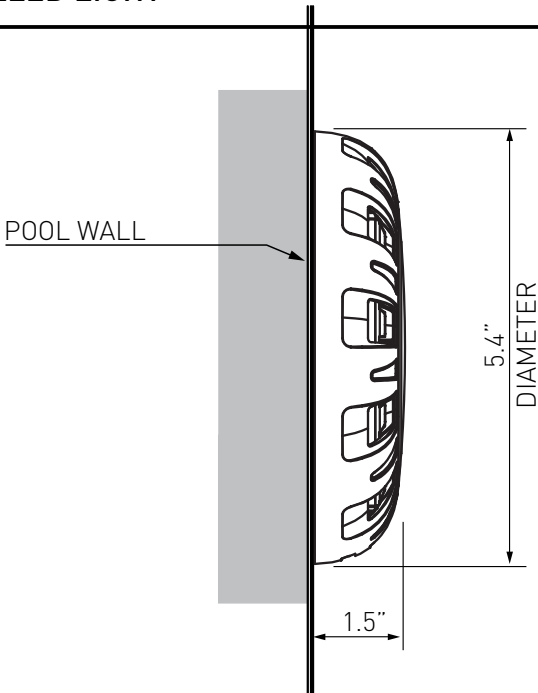

TROUBLESHOOTING

ISSUE	REASON	ACTION
Light returns to WHITE color during manual color change.	Light synchronization process has been triggered.	Refer to MULTI PLUS User Guide instructions. (Pg. 3)
Light flashes (RED)	Light over heating	Check light is fully submerged. Check vents are not obstructed
Light not operating (1)	Faulty connection to transformer	Ensure cable correctly connected to transformer terminals
Light not operating (2)	Mains power not connected	Check transformer is plugged into GPO and switched on
Light not operating (3)	Damaged cable	Disconnect plug top and test voltage under load using multi-meter (ie. 20w 12v)
Light not operating (4)	Transformer not working	Check fuses & test transformer using multimeter under load (ie.15W 12V)
Light not operating (5)	Damage caused by high voltage and/or incorrect power supply.	Return product to your local Spa Electrics reseller or Spa Electrics for repair
Light colors not synchronized	Incorrect operating mode selected.	Refer to MULTI PLUS setup procedure (pg. 3)

If these issues cannot be resolved with the above recommended actions, please contact your local Spa Electrics reseller or Spa Electrics directly.

Web: www.spaelectrics.com

ELECTRICAL GROUNDING

Underwriters Laboratories (UL) Statement

Per the NEC, NFPA 70, Article 680.23 (B)(5), states that bonding shall not be required for luminaires that are listed for the application and have no non-current carrying metal parts. In addition, per Article 680.26 (B)(4), exception states that Listed low-voltage lighting systems with non-metallic forming shells shall not require bonding.

Therefore, luminaires with polymeric/non-current carrying metal parts are not required to be grounded / bonded.

Manufacturers Statement

Spa Electrics ARGON luminaires with their plastic housing designs and plastic niches do not require grounding / bonding.

Spa Electrics ARGON lights have also been determined to comply with the applicable requirements for wet-niche, LED type Swimming Pool and Spa Luminaires.

FCC COMPLIANCE STATEMENT

This device complies with part 15 of the FCC rules. Operation is subject to the following two (2) conditions:

- (1) This device may not cause harmful interference, and
- (2) this device must accept any interference received, including interference that may cause undesired operation.

Note: This equipment has been tested and found to comply with the limits for a Class B digital device, pursuant to part 15 of the FCC Rules. These limits are designed to provide reasonable protection against harmful interference in a residential installation. This equipment generates, uses and can radiate radio frequency energy and, if not installed and used in accordance with the instructions, may cause harmful interference to radio communications. However, there is no guarantee that interference will not occur in a particular installation. If this equipment does cause harmful interference to radio or television reception, which can be determined by turning the equipment off and on, the user is encouraged to try to correct the interference by one or more of the following measures:

- Reorient or relocate the receiving antenna.
- Increase the separation between the equipment and receiver.
- Connect the equipment into an outlet on a circuit different to that to which the receiver is connected.
- Consult the dealer or an experienced radio / TV technician for help.

Do not make any changes or modifications to the equipment unless otherwise specified in the manual.



NOTE

PLEASE STORE THIS
MANUAL IN A SAFE PLACE
FOR FUTURE REFERENCE



Proudly manufactured by

Spa Electrics



www.spaelectrics.com

© COPYRIGHT 2020 SPA ELECTRICS PTY. LTD.
ALL RIGHTS RESERVED

US 20201113