

Parts List			
ITEM	QTY	PART NUMBER	DESCRIPTION
1	1	ESC-1336-B	BRACE, 41.79" X 30.9" TRD SUPPORT
2	1	ESC-1336-BB	BRACE, 19.86" X 17.79" BENCH SUPPORT
3	1	ESC-1336-BRC	REV. RAD, 4'-0" X 38.18" X 3" BOTTOM TRD RISER CAP
4	1	ESC-1336-BRR	REV. RAD, 4'-0" X 38.18" X 9" BOTTOM TREAD RISER, RIGHT
5	1	ESC-1336-CNR	REV. RAD, 2'-0" X 28.47" X 20" CRN TREAD RISER
6	1	ESC-1336-CRL	REV. RAD, 2'-0" X 28.47" X 3" CRN TREAD RISER CAP
7	1	ESC-1336-MRC	REV. RAD, 3'-0" X 43.24" X 3" MIDDLE TRD RISER CAP
8	1	ESC-1336-MRR	REV. RAD, 3'-0" X 43.24" X 20" MIDDLE TREAD RISER, RIGHT
9	1	ESC-1336-RIS	RADIUS, 7'-0" X 21" X 42" RISER
10	1	ESC-1336-SBL	RADIUS, 5'-6" X 25.5" X 3" STEP/BENCH RISER CAP
11	1	ESC-1336-SBR	RADIUS, 5'-6" X 25.5" X 20" STEP/BENCH TREAD RISER
12	1	ESC-1336-SWR	RADIUS, 7' 0" X 63" SIDE WALL, RIGHT
13	1	ESC-1336-TRC	REV. RAD, 2'-0" X 28.47" X 3" TOP TREAD RISER CAP
14	1	ESC-1336-TRR	REV. RADIUS, 2'-0" X 28.47" X 31" TOP TREAD RISER
15	1	SSC-1099	BEAD RECEIVER, 12' REQUIRED

APPLY TREAD EDGE TREATMENT TO ALL EXPOSED STEP TREADS. A TOTAL OF 185" OF TREATMENT REQUIRED FOR ALL TREADS.

PLEASE REFER TO:
CONTRACTOR NOTE

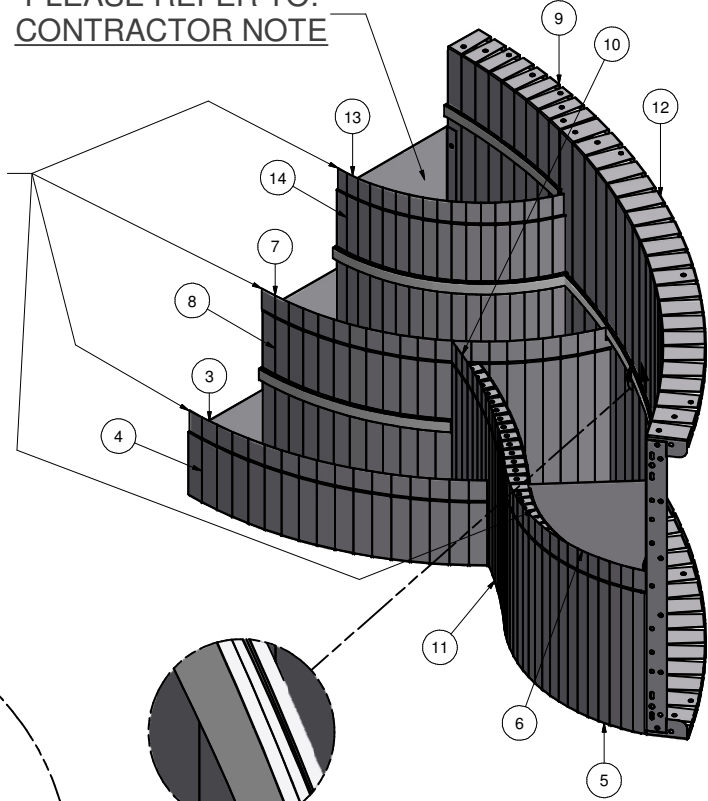

CONTRACTOR NOTE:
BACK FILL STEP & BENCH AREA WITH COMPACTED EARTH MATERIAL. FINISH BENCH AREA WITH 2" OF HARDEN FLOOR MATERIAL. LEVEL WITH TOP OF BEAD RECEIVER.

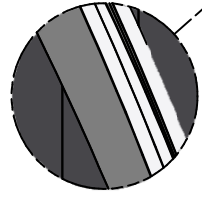
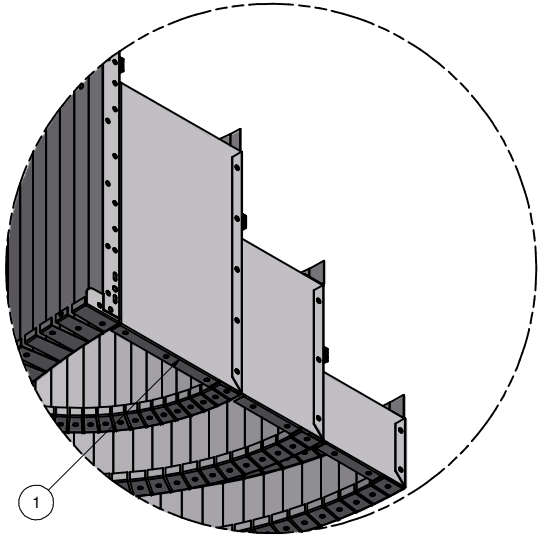
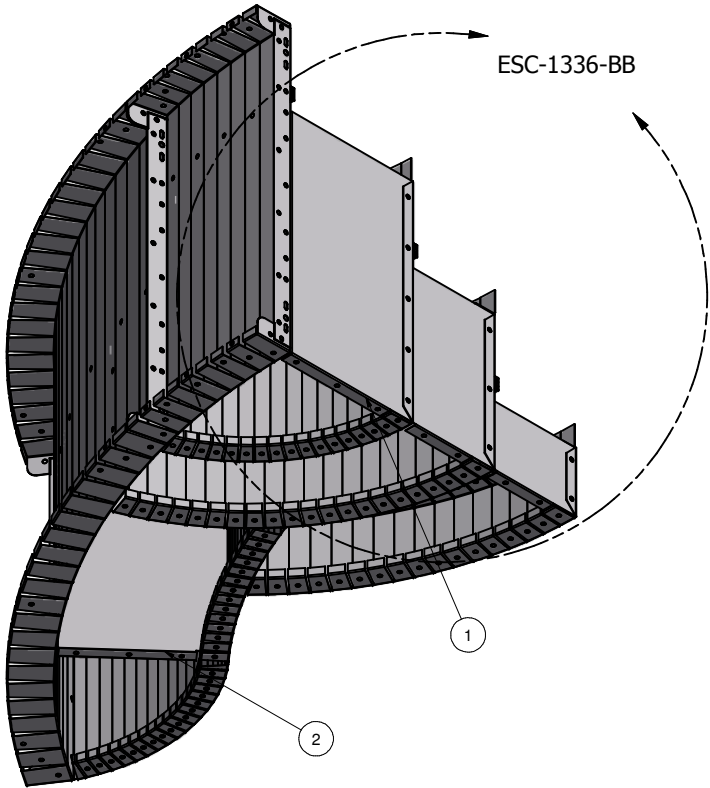

BEAD RECEIVER DETAIL

KEEP BEAD RECEIVERS ATTACHED TO THE STEP & BENCH TREADS, AND TO WALL PANELS FOR SHIPPING. A TOTAL OF 144" (12') OF BEAD RECEIVER IS REQUIRED.

ESC-1336-BB

7'R OPEN TOP WC STEP W/ BENCH - RIGHT

PART #: ESC-1336 	WEIGHT: 228.43 lbmass	MACHINE TIME: N/A	FILE/DIRECTORY: I:\PRODUCT_CATALOG\2013 SS\ESC-1336.idw
	TOLERANCES EXCEPT AS NOTED 0/0 0.0 0.00 0.000 0' ±1/8 ±0.25 ±0.0625 ±0.03125 ±1/2"	MATERIAL:	DATE: 12/20/2013
		DRAWN BY: GR	SHEET: 1 OF 14

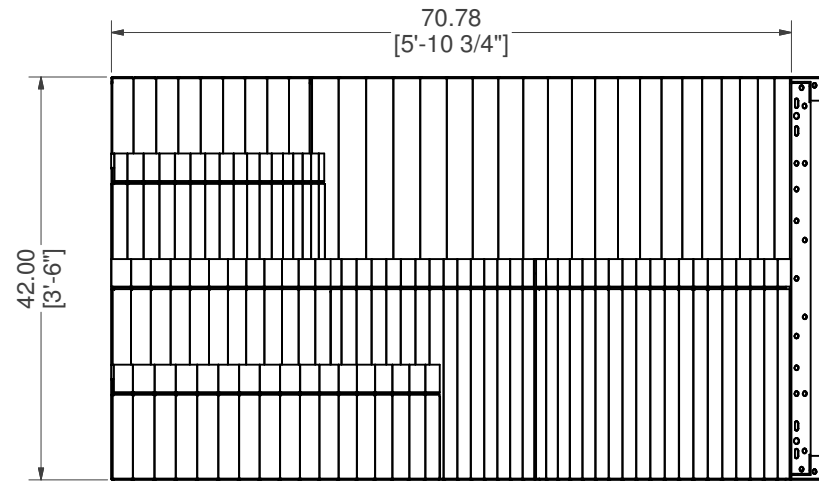
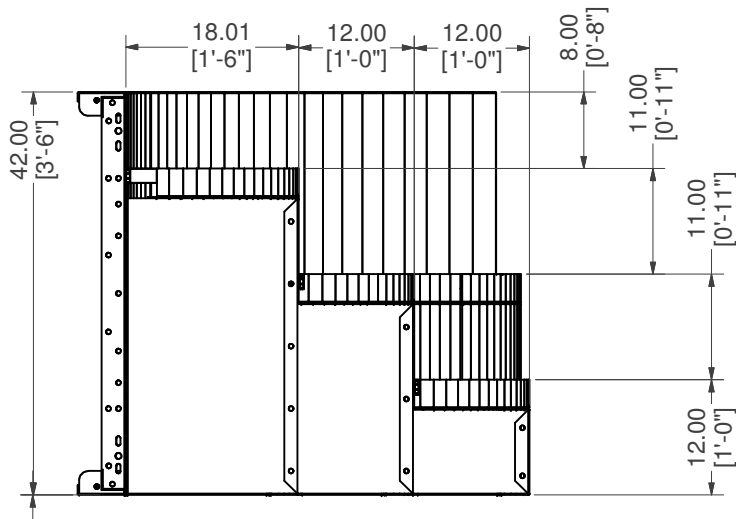
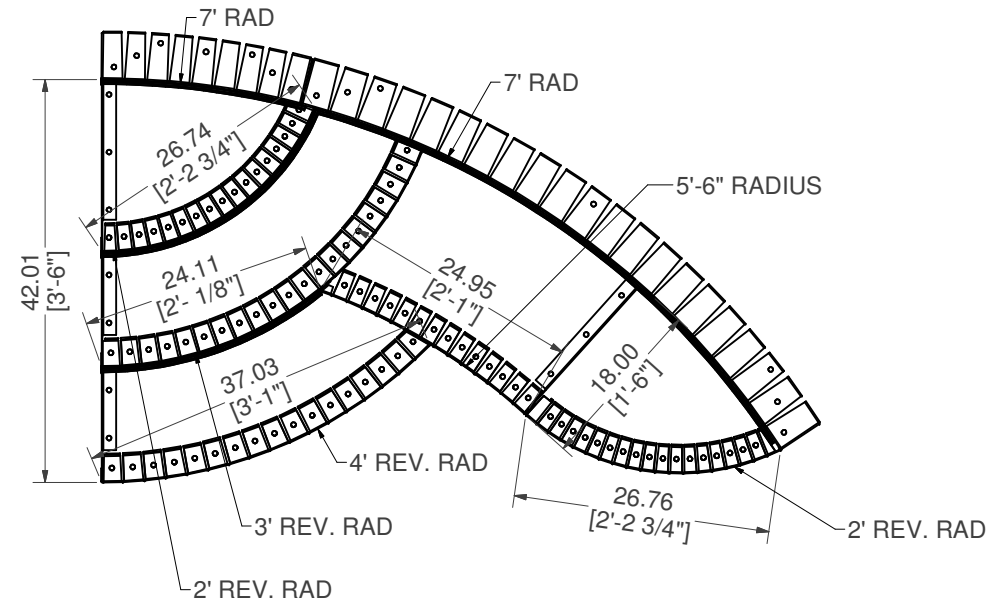
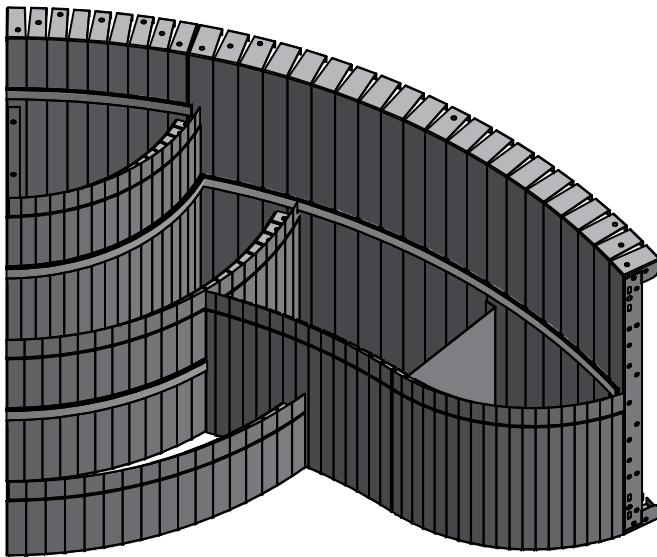

7'R OPEN TOP WC STEP W/ BENCH - RIGHT

PART #: 00
[0'-0"]

ESC-1336

WEIGHT:

228.43 lbmass

MACHINE TIME:

N/A

FILE/DIRECTORY:

I:\PRODUCT_CATALOG\2013 SS\ESC-1336.idw

TOLERANCES EXCEPT AS NOTED

0/0 0.0 0.00 0.000 0'
±1/8 ±0.25 ±0.0625 ±0.03125 ±1/2"

MATERIAL:

DRAWN BY:

GR

DATE:

12/20/2013

SHEET:

2 OF 14

NOTES:

