

Parts List			
ITEM	QTY	PART NUMBER	DESCRIPTION
1	152	COP-TSCREW-1	COPING TEK SCREW EACH
2	80	COP-KCVRET-W-1	COP COPING STIFFNER 1 5/8"-1PC
3	3	ESC-1418-BBR	BRACE, 7.5" X 11.86" BOTTOM RISER SUPPORT
4	3	ESC-1418-BR	STRAIGHT, 72" X 9.5" BOTTOM RISER
5	3	ESC-1418-BWR	STRAIGHT, 6'-0", 1 RIB, PLAIN
6	12	ESC-1418-LV	STRAIGHT, 71" X 1.5" X 1.5" LEVELER
7	3	ESC-1418-MBR	BRACE, 18" X 11.86" MIDDLE RISER SUPPORT
8	3	ESC-1418-MR	STRAIGHT, 72" X 19.5" MIDDLE RISER
9	2	ESC-1418-RSB	BRACE, 48" X 53" RISER SUPPORT
10	1	ESC-1418-SWL	STRAIGHT, 4'-0", 0 RIBS, PLAIN
11	1	ESC-1418-SWR	STRAIGHT, 4'-0", 0 RIBS, PLAIN
12	3	ESC-1418-TBR	BRACE, 38" X 11.86" TOP RISER SUPPORT
13	3	ESC-1418-TMBR	BRACE, 28" X 11.86" MIDDLE RISER SUPPORT
14	3	ESC-1418-TMR	STRAIGHT, 72" X 29.5" TOP MIDDLE RISER
15	3	ESC-1418-TR	STRAIGHT, 72" X 39.5" TOP RISER
16	1	OPC-CONREC-120	72" PVC CONCRETE RECEPTOR REQUIRED
17	2	OPN-AB90	2.5" X 2.5" X 48" X 90 DEG OPN CORNER BRACE
18	-	SCC-1099	BEAD RECEIVER, 74' REQUIRED

NOTE:
INCLUDE 3" DIAGONAL CORNER
FOAM INSERTS (PART# 12-159)
WITH THIS STEP, 6" LONG.

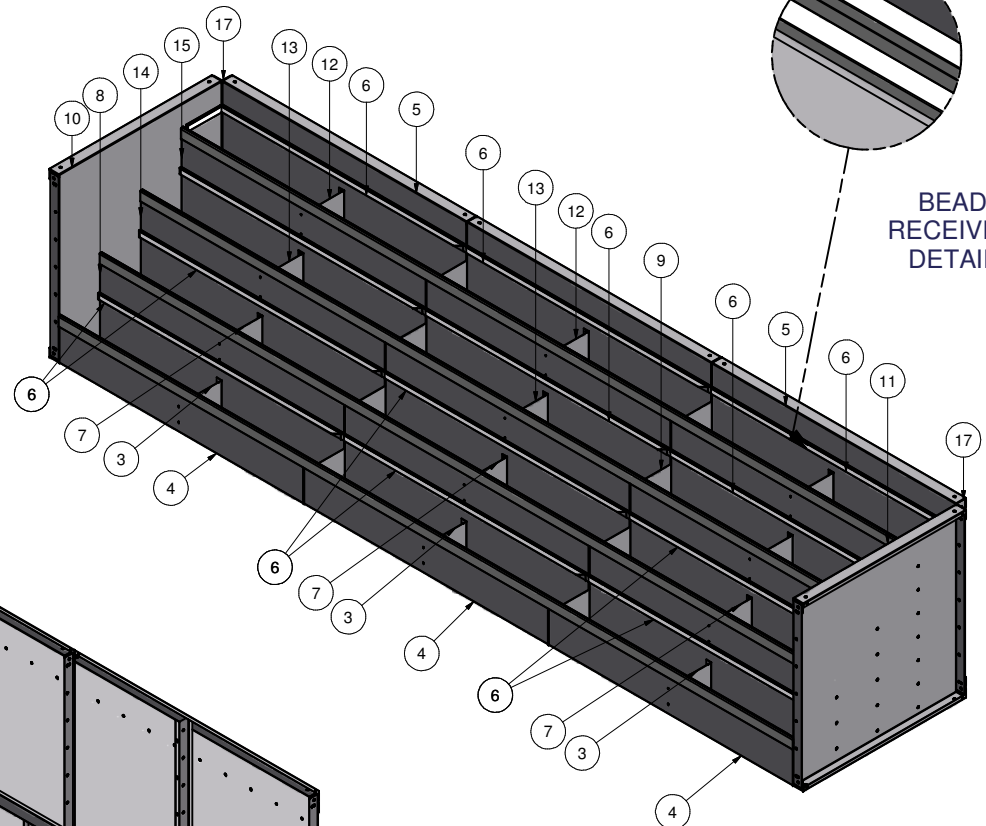

KEEP BEAD RECEIVERS ATTACHED TO THE
STEP TREADS FOR SHIPPING. A TOTAL OF
888" (74') OF BEAD RECEIVER IS REQUIRED.

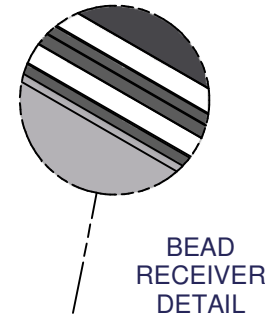
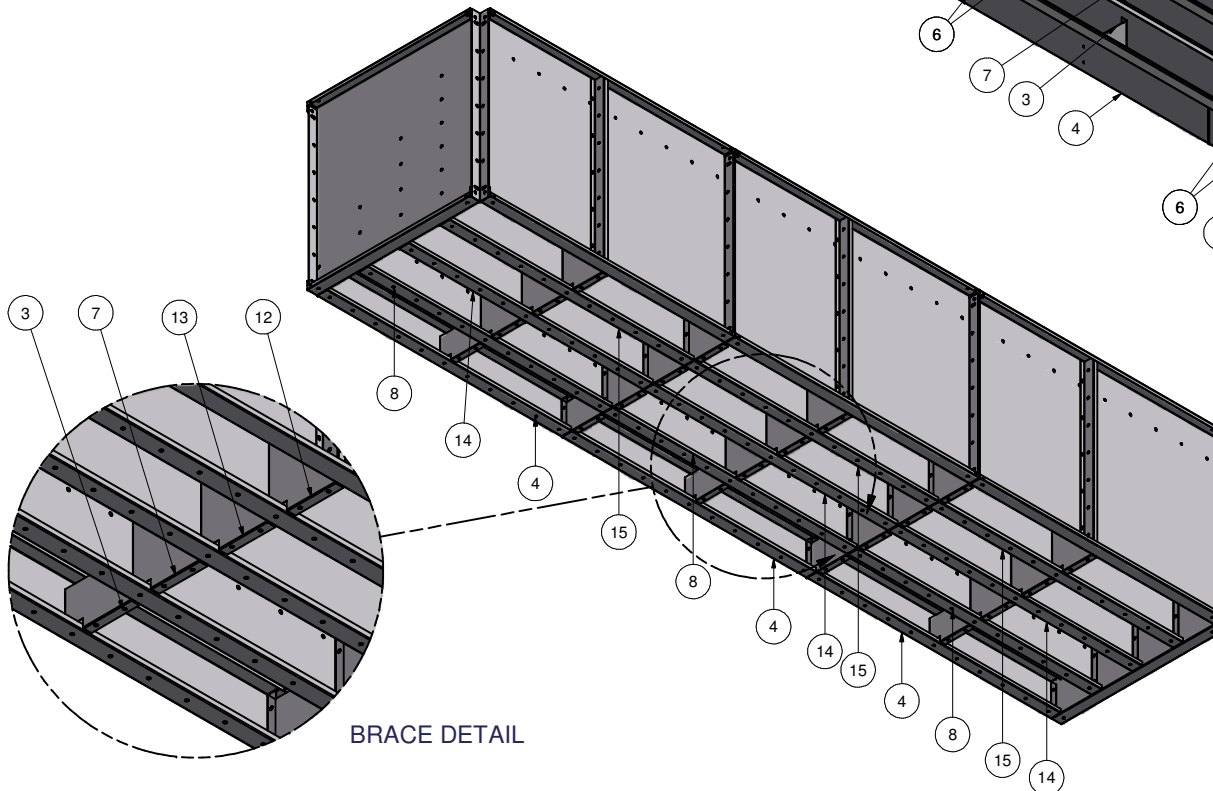

18' X 48" OPN STEP

PART #: ESC-1418

WEIGHT:
N/A

MACHINE TIME:
N/A

FILE/DIRECTORY:

I:\PRODUCT_CATALOG\2014 SS\ESC-1418.idw

**LATHAM
INTERNATIONAL**

TOLERANCES EXCEPT
AS NOTED
0/0 0.0 0.00 0.000 0'
±1/8 ±0.25 ±0.0625 ±0.03125 ±1/2"

MATERIAL:

DATE: 4/4/2014

NOTES:

DRAWN BY: TS

SHEET: 1 OF 14

NOTE:
 INCLUDE 3" DIAGONAL CORNER
 FOAM INSERTS (PART# 12-159)
 WITH THIS STEP, 8" LONG.

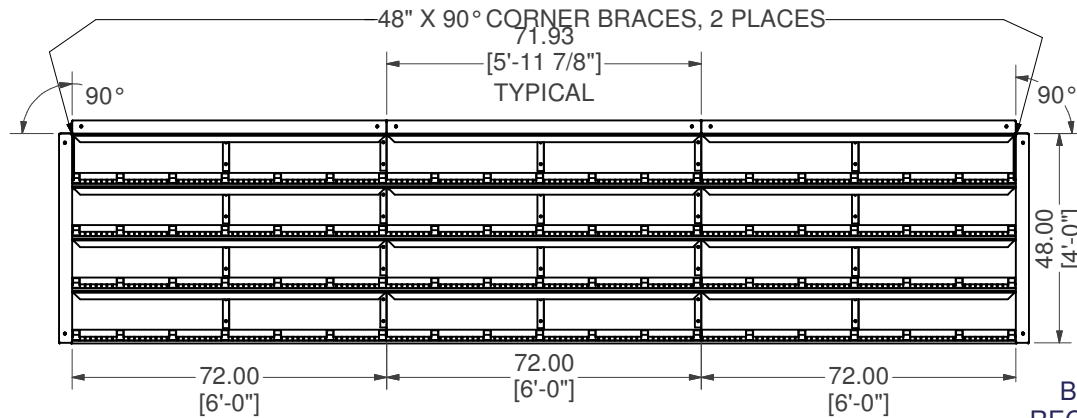
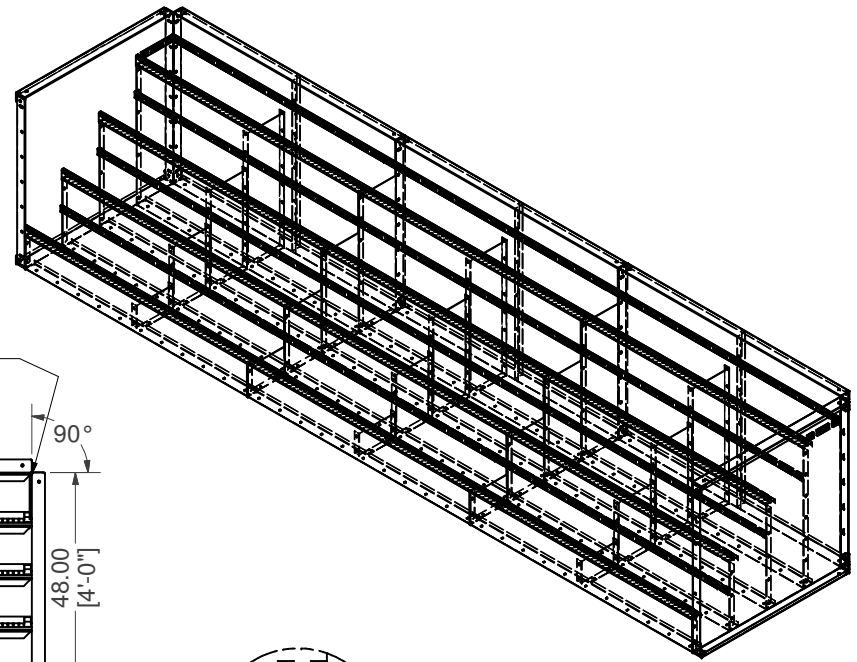

BEAD
 RECEIVER
 DETAIL

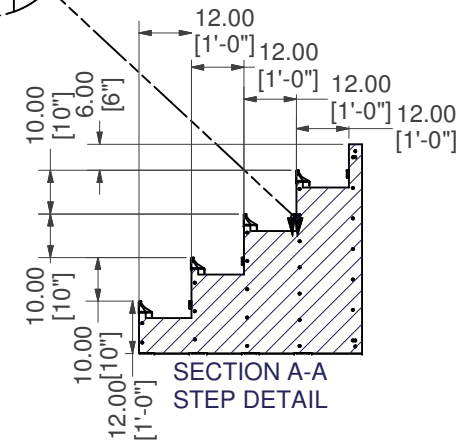
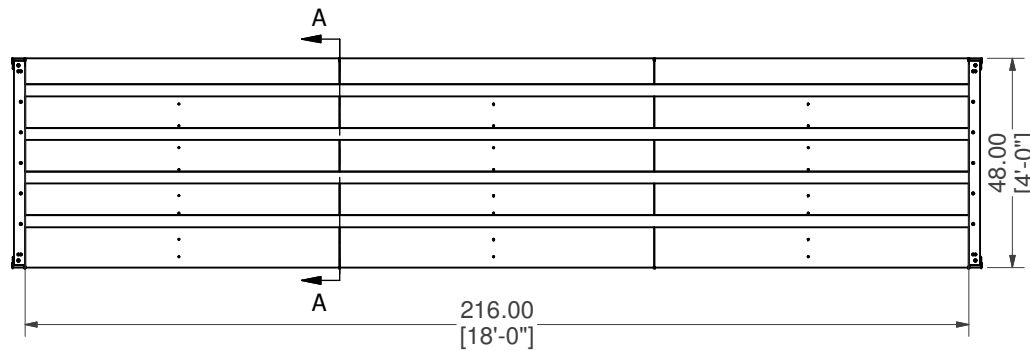
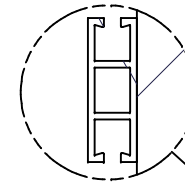

18' X 48" OPN STEP

PART #: ESC-1418 	WEIGHT: N/A	MACHINE TIME: N/A	FILE/DIRECTORY: I:\PRODUCT_CATALOG\2014 SS\ESC-1418.idw
	TOLERANCES EXCEPT AS NOTED 0/0 0.0 0.00 0.000 0' ±1/8 ±0.25 ±0.0625 ±0.03125 ±1/2"	MATERIAL: DRAWN BY: TS	DATE: 4/4/2014 SHEET: 2 OF 14

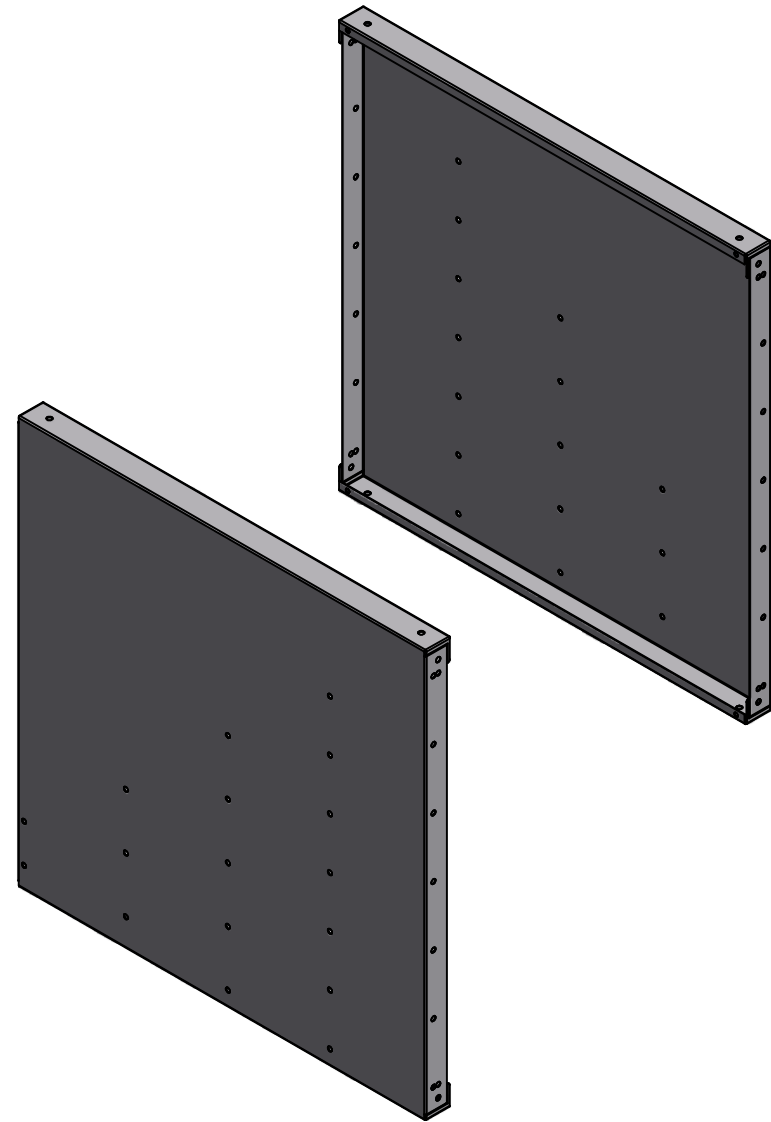
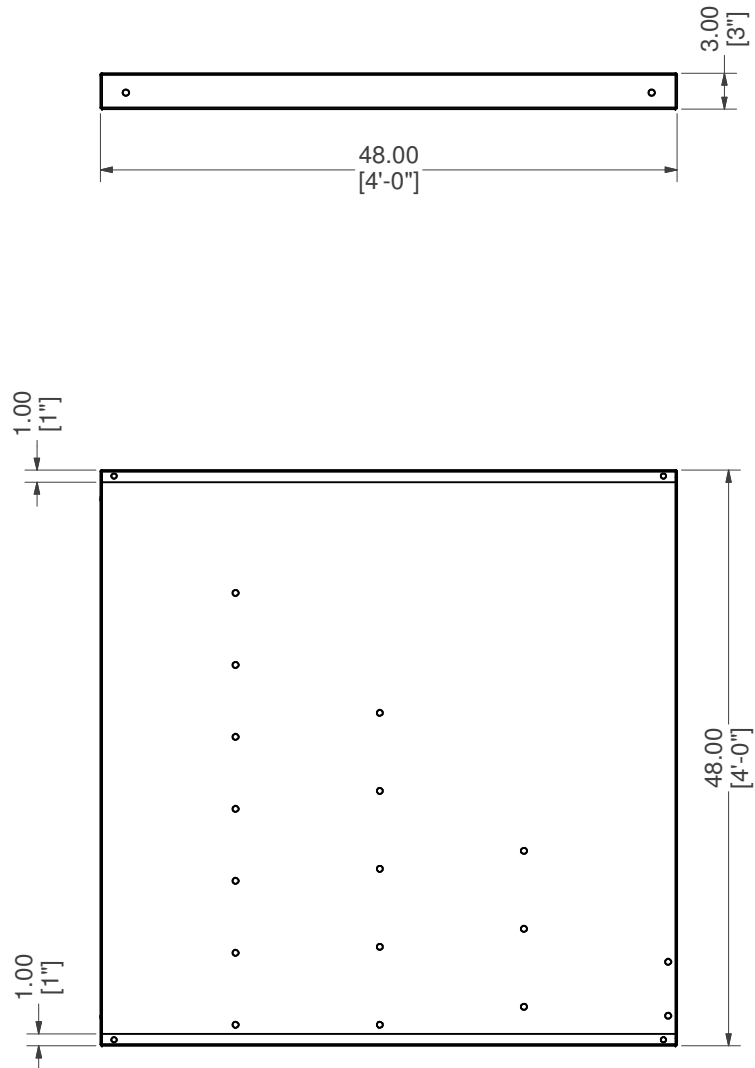

NOTE:
LEFT SIDE AND RIGHT SIDE STEP
PARTS ARE SYMMETRICAL.

STRAIGHT, 4'-0", 0 RIBS, PLAIN

PART #: ESC-1418-SWL

WEIGHT:
58.61 lbmass

MACHINE TIME:
N/A

FILE/DIRECTORY:

I:\PRODUCT_CATALOG\2014 SS\ESC-1418.idw

TOLERANCES EXCEPT
AS NOTED

0/0 0.0 0.00 0.000 0'
±1/8 ±0.25 ±0.0625 ±0.03125 ±1/2'

MATERIAL:
14 GA. GALVANIZED

DATE : 4/4/2014

NOTES:

DRAWN BY: TS

SHEET : 3 OF 14

LATHAM
INTERNATIONAL

Parts List			
ITEM	QTY	PART NUMBER	DESCRIPTION
1	1	ESC-1418-BWR	STRAIGHT, 6'-0", 1 RIB, PLAIN
2	1	48-Z-RIB	48" Z-RIB

MANUALLY WELDED AT 32.5" FROM LEADING EDGE

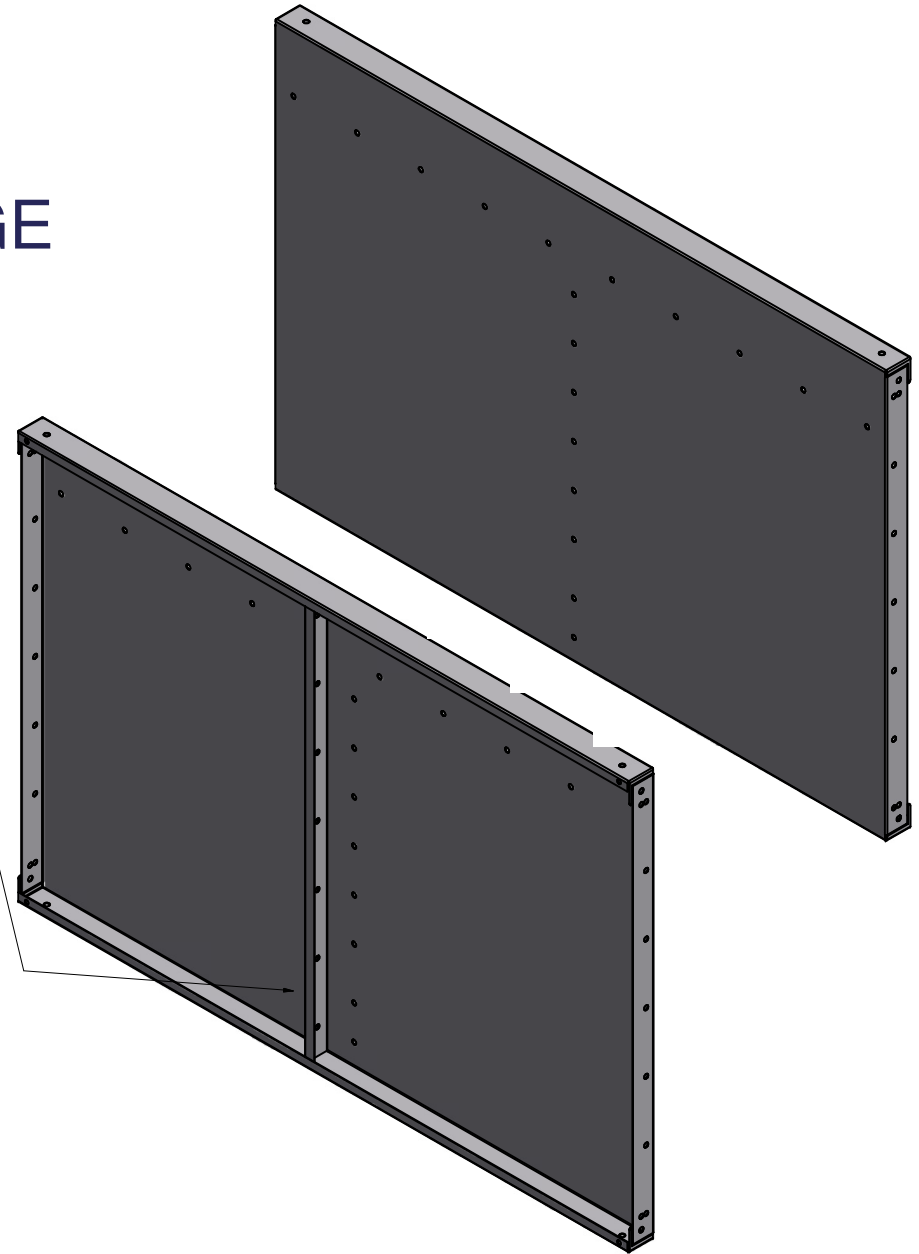
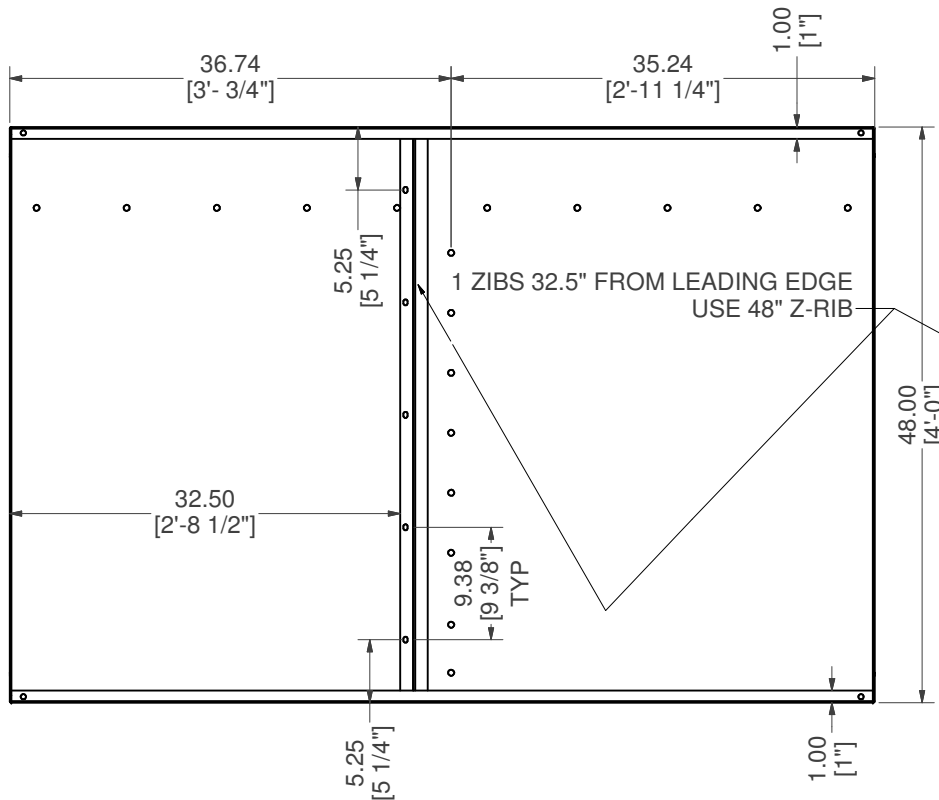
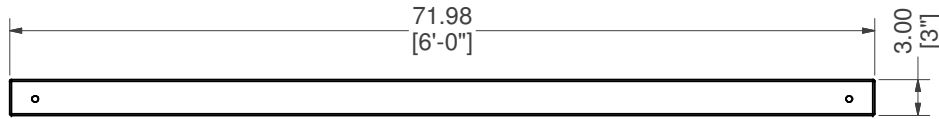

STRAIGHT, 6'-0", 1 RIB, PLAIN

PART #: ESC-1418-BWR

WEIGHT:
90.36 lbmass

MACHINE TIME:
N/A

FILE/DIRECTORY:

I:\PRODUCT_CATALOG\2014 SS\ESC-1418.idw



TOLERANCES EXCEPT AS NOTED
0/0 0.0 0.00 0.000 0'
±1/8 ±0.25 ±0.0625 ±0.03125 ±1/2'

MATERIAL:
DRAWN BY: TS

DATE: 4/4/2014
SHEET: 4 OF 14

NOTES:

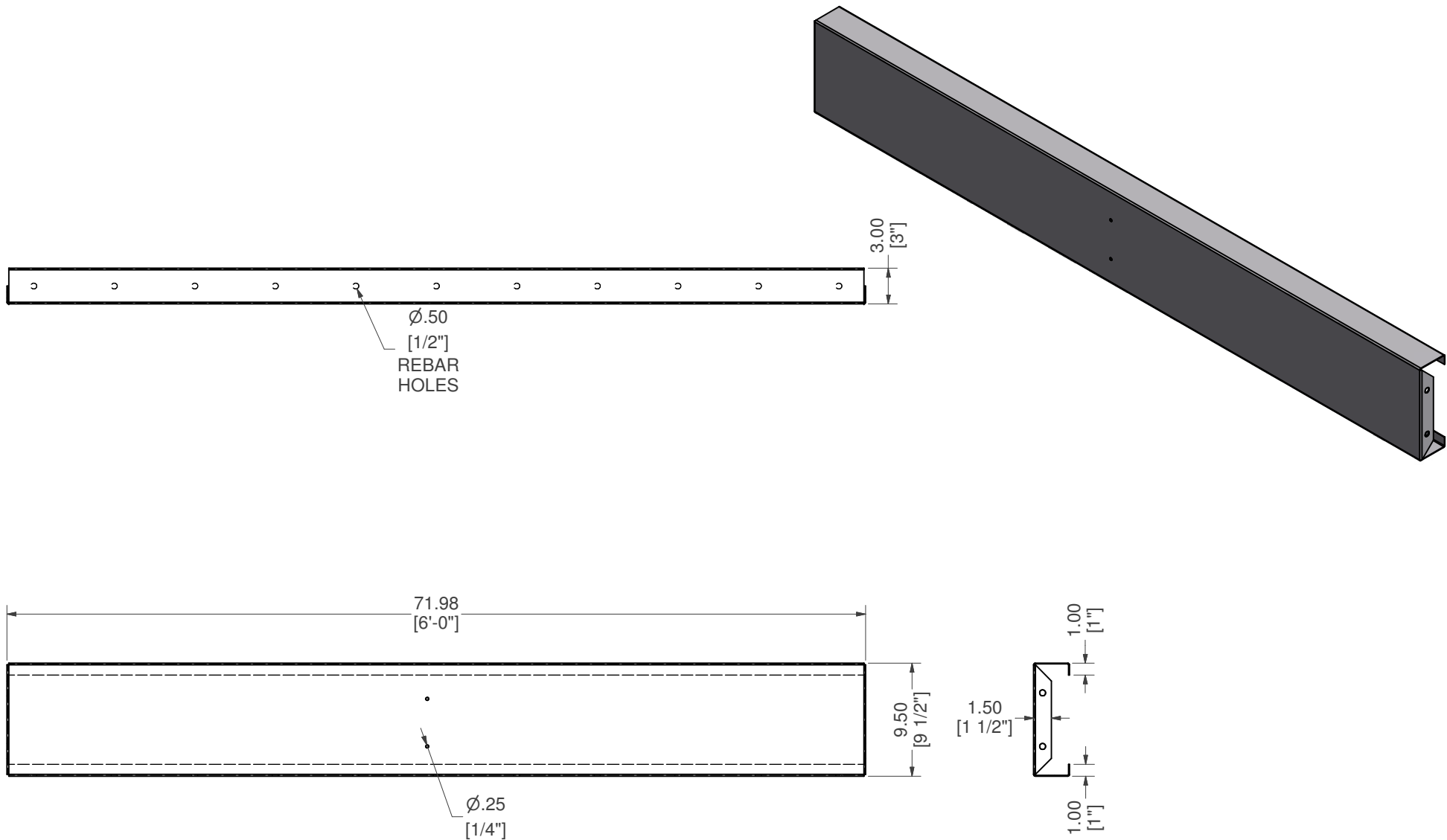

STRAIGHT, 72" X 9.5" BOTTOM RISER

PART #: ESC-1418-BR

WEIGHT:
25.26 lbmass

MACHINE TIME:
N/A

FILE/DIRECTORY:

I:\PRODUCT_CATALOG\2014 SS\ESC-1418.idw

TOLERANCES EXCEPT
AS NOTED

MATERIAL:
14 GA. GALVANIZED

DATE : 4/4/2014

NOTES:

0/0 0.0 0.00 0.000 0'
±1/8 ±0.25 ±0.0625 ±0.03125 ±1/2'

DRAWN BY: TS

SHEET : 5 OF 14

LATHAM
INTERNATIONAL

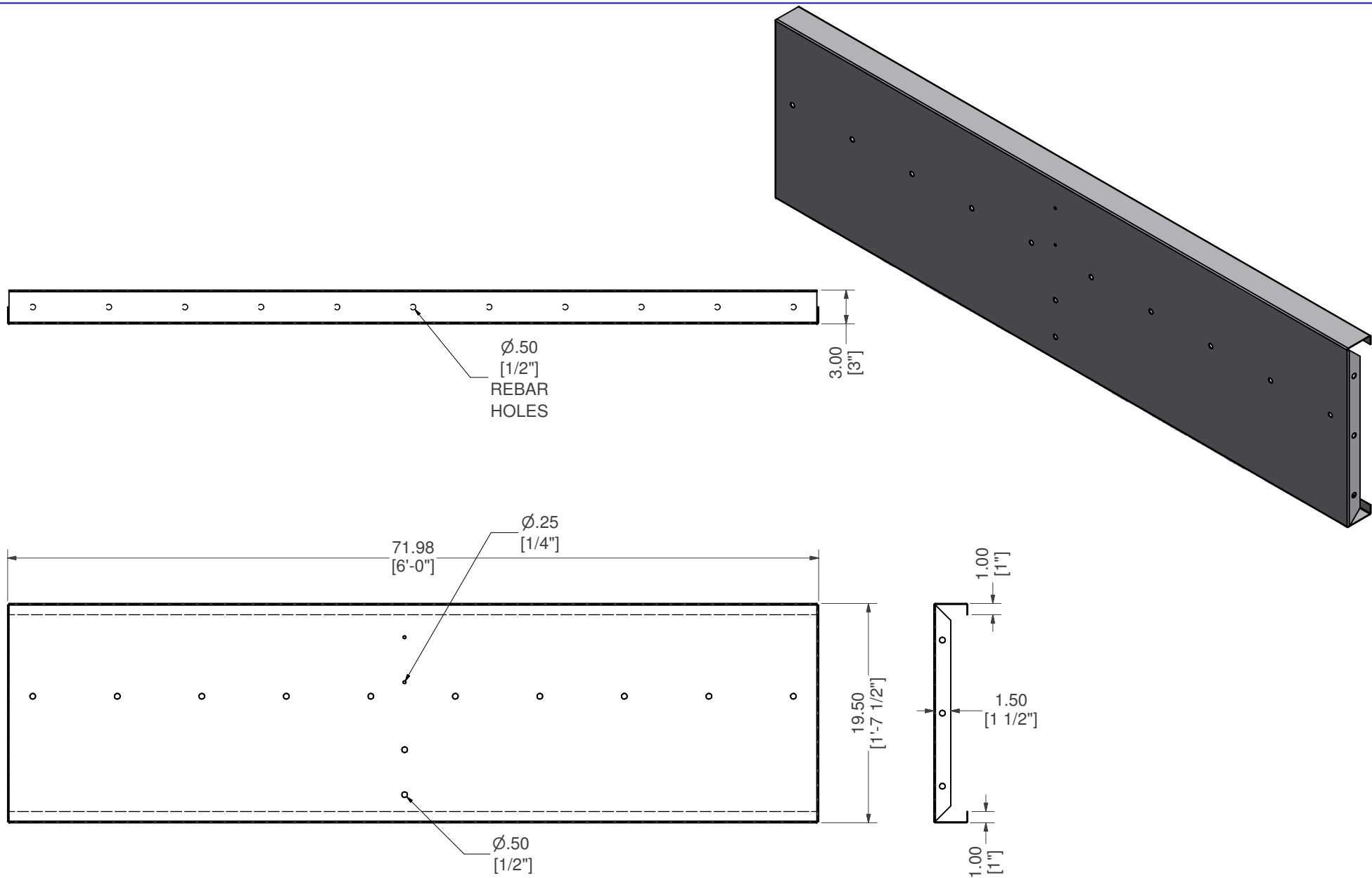

STRAIGHT, 72" X 19.5" MIDDLE RISER

PART #: ESC-1418-MR

WEIGHT:
40.39 lbmass

MACHINE TIME:
N/A

FILE/DIRECTORY:

I:\PRODUCT_CATALOG\2014 SS\ESC-1418.idw

TOLERANCES EXCEPT
AS NOTED

0/0 0.0 0.00 0.000 0'
±1/8 ±0.25 ±0.0625 ±0.03125 ±1/2"

MATERIAL:
14 GA. GALVANIZED

DATE: 4/4/2014

NOTES:

DRAWN BY: TS

SHEET: 6 OF 14

LATHAM
INTERNATIONAL

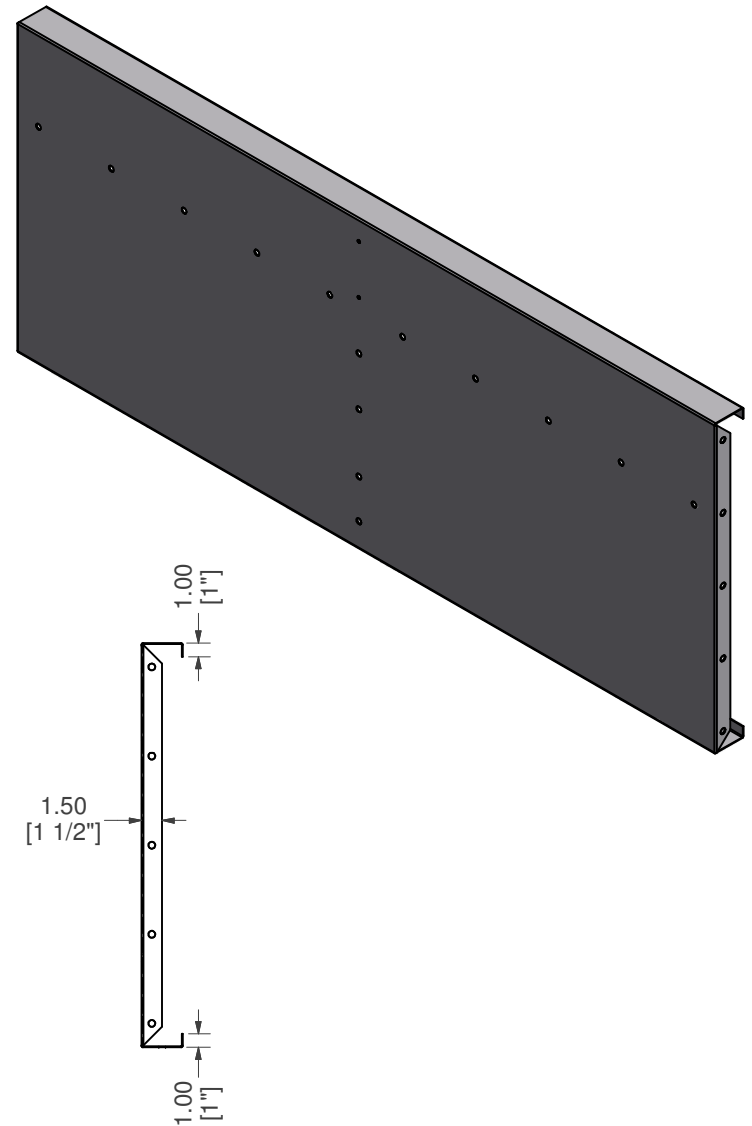
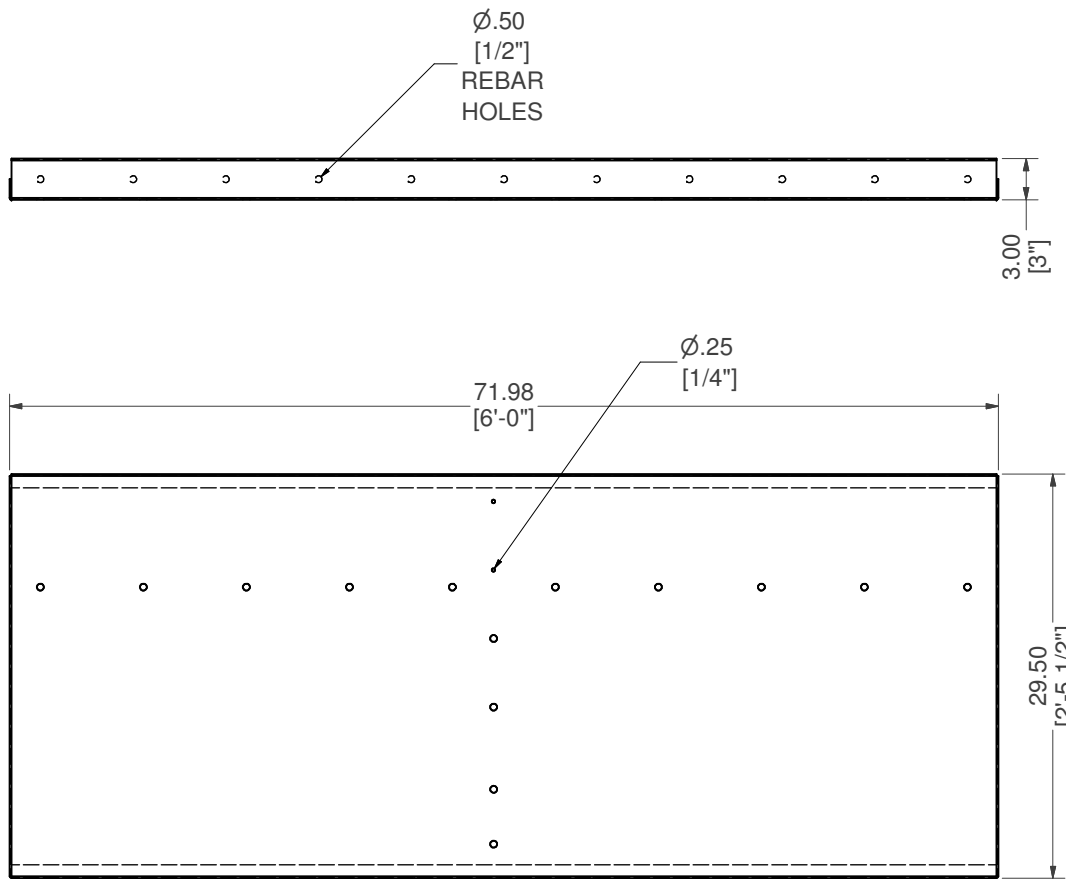

STRAIGHT, 72" X 29.5" TOP MIDDLE RISER

PART #: ESC-1418-TMR

WEIGHT:
55.55 lbmass

MACHINE TIME:
N/A

FILE/DIRECTORY:

I:\PRODUCT_CATALOG\2014 SS\ESC-1418.idw

TOLERANCES EXCEPT AS NOTED

MATERIAL:
14 GA. GALVANIZED

DATE: 4/4/2014

NOTES:

0/0 0.0 0.00 0.000 0'
±1/8 ±0.25 ±0.0625 ±0.03125 ±1/2'

DRAWN BY: TS

SHEET: 7 OF 14

LATHAM
INTERNATIONAL

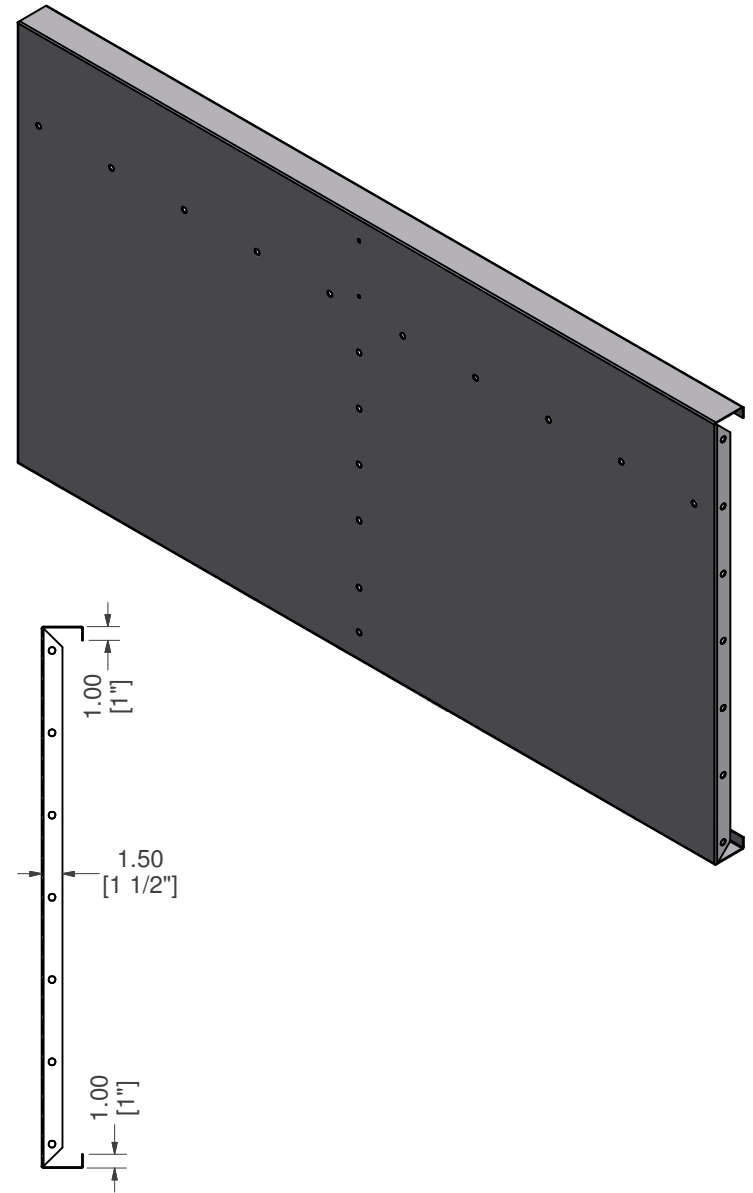
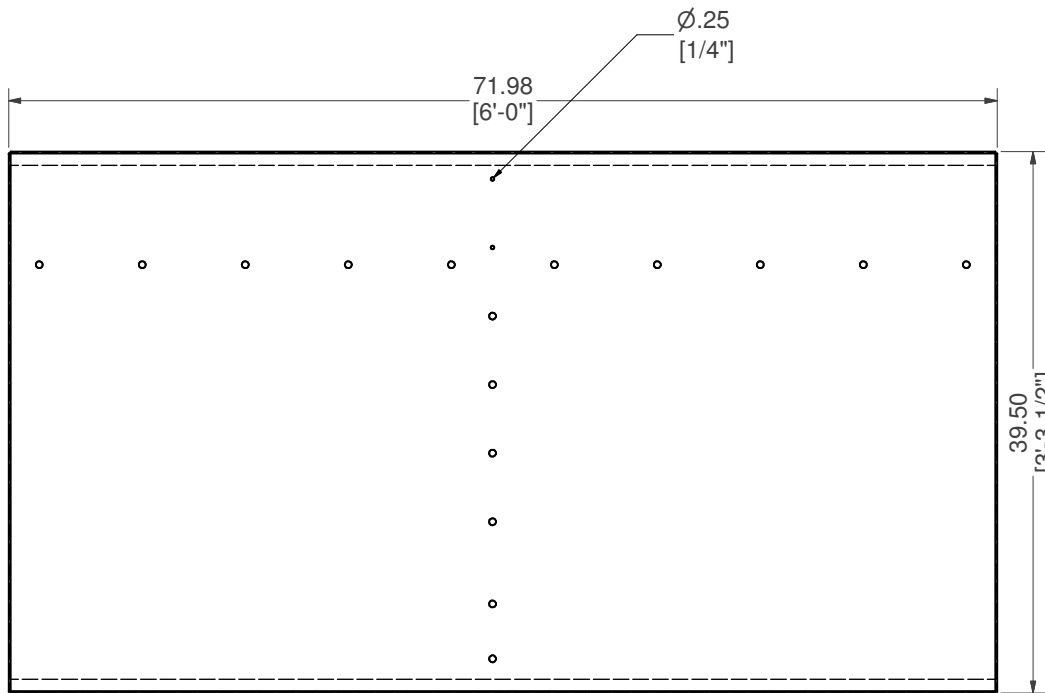
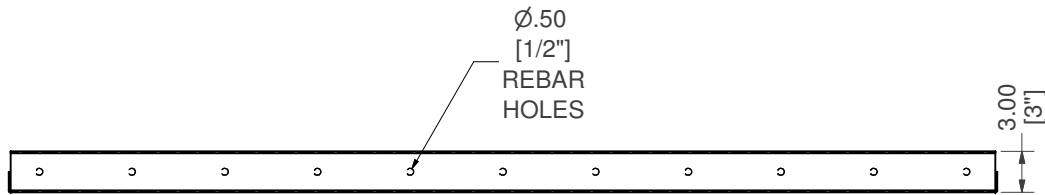

STRAIGHT, 72" X 39.5" TOP RISER

PART #: ESC-1418-TR

WEIGHT:
70.72 lbmass

MACHINE TIME:
N/A

FILE/DIRECTORY:

I:\PRODUCT_CATALOG\2014 SS\ESC-1418.idw



TOLERANCES EXCEPT AS NOTED
0/0 0.0 0.00 0.000 0'
±1/8 ±0.25 ±0.0625 ±0.03125 ±1/2'

MATERIAL:
14 GA. GALVANIZED

DATE : 4/4/2014

NOTES:

DRAWN BY: TS

SHEET : 8 OF 14

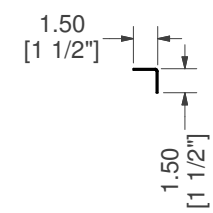
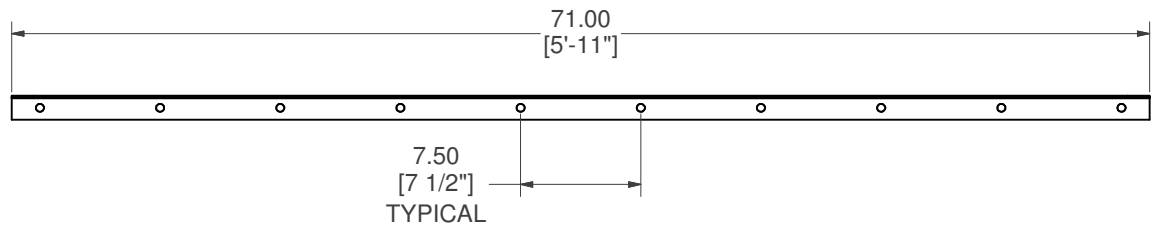
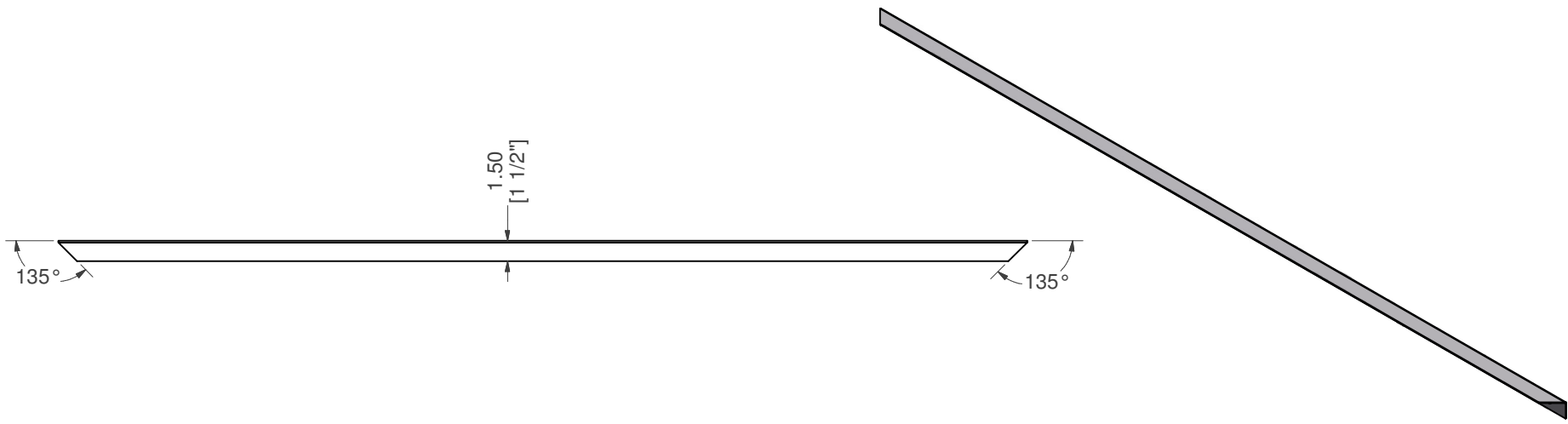

STRAIGHT, 71" X 1.5" X 1.5" LEVELER

PART #: ESC-1418-LV 	WEIGHT: 4.08 lbmass	MACHINE TIME: N/A	FILE/DIRECTORY: I:\PRODUCT_CATALOG\2014 SS\ESC-1418.idw
	TOLERANCES EXCEPT AS NOTED 0/0 0.0 0.00 0.000 0' ±1/8 ±0.25 ±0.0625 ±0.03125 ±1/2'	MATERIAL: 14 GA. GALVANIZED	DATE : 4/4/2014
	DRAWN BY: TS	SHEET : 9 OF 14	

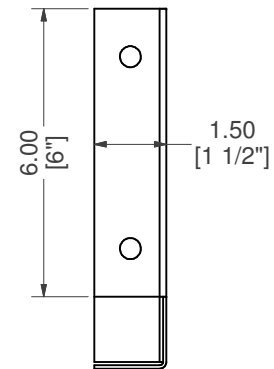
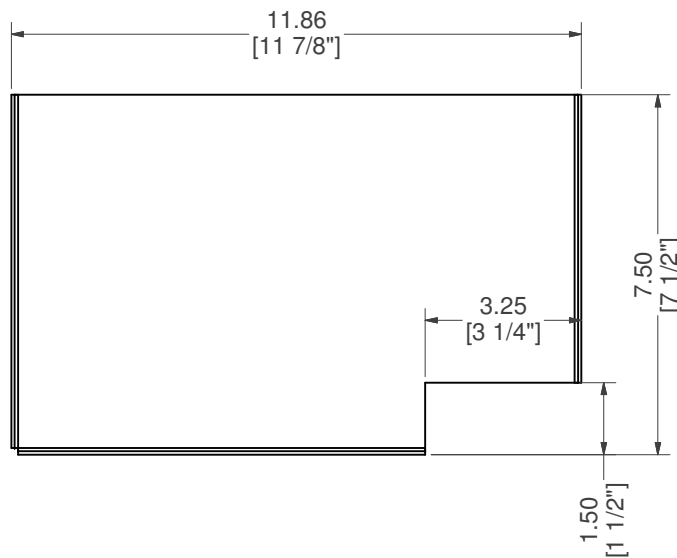
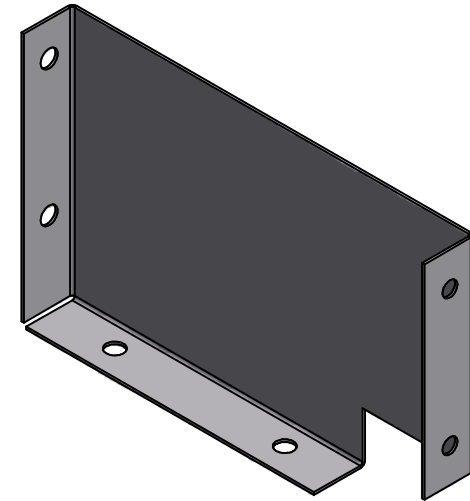
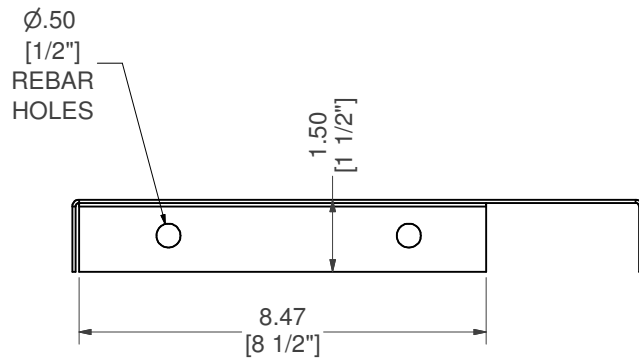

BRACE, 7.5" X 11.86" BOTTOM RISER SUPPORT

PART #: ESC-1418-BBR

WEIGHT:
2.30 lbmass

MACHINE TIME:
N/A

FILE/DIRECTORY:

I:\PRODUCT_CATALOG\2014 SS\ESC-1418.idw



TOLERANCES EXCEPT AS NOTED
0/0 0.0 0.00 0.000 0'
±1/8 ±0.25 ±0.0625 ±0.03125 ±1/2'

MATERIAL:
14 GA. GALVANIZED

DATE : 4/4/2014

NOTES:

DRAWN BY: TS

SHEET : 10 OF 14

Ø.50
[1/2"]
REBAR
HOLES

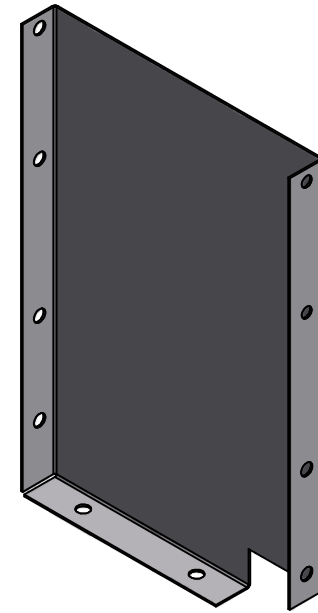
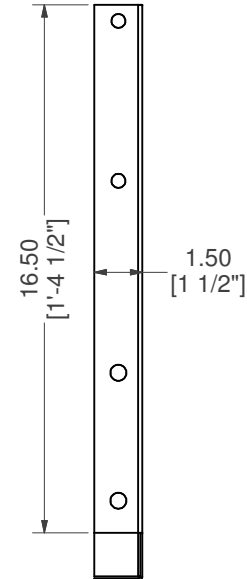
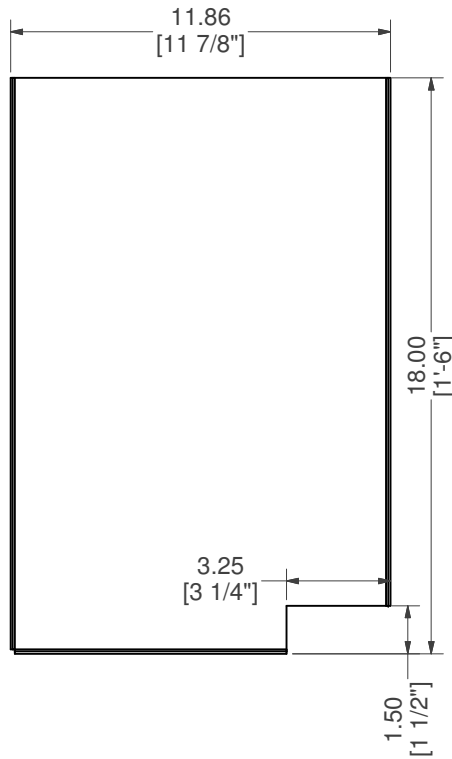
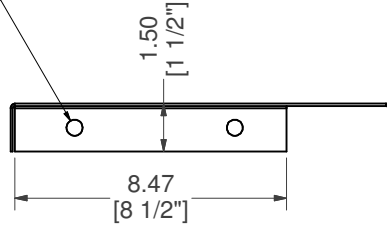

BRACE, 18" X 11.86" MIDDLE RISER SUPPORT

PART #: ESC-1418-MBR

WEIGHT:
5.41 lbmass

MACHINE TIME:
N/A

FILE/DIRECTORY:

I:\PRODUCT_CATALOG\2014 SS\ESC-1418.idw



TOLERANCES EXCEPT AS NOTED

0/0 0.0 0.00 0.000 0'

±1/8 ±0.25 ±0.0625 ±0.03125 ±1/2'

MATERIAL:
14 GA. GALVANIZED

DATE: 4/4/2014

NOTES:

DRAWN BY: TS

SHEET: 11 OF 14

Ø.50
[1/2"]
REBAR
HOLES

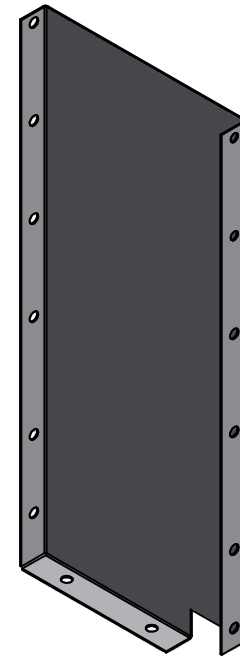
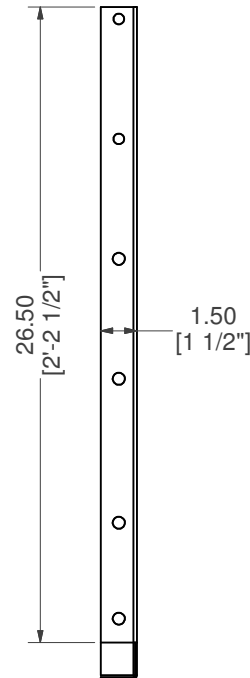
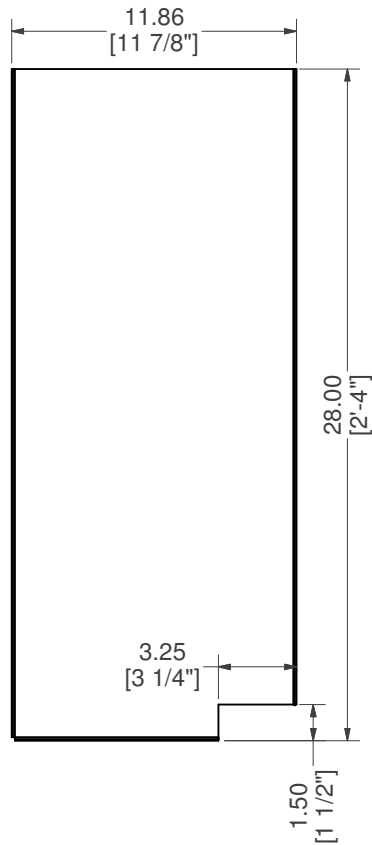
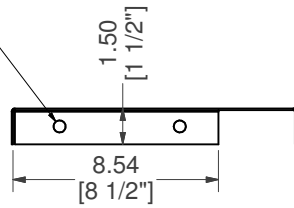

BRACE, 28" X 11.86" MIDDLE RISER SUPPORT

PART #: ESC-1418-TMBR

WEIGHT:
8.36 lbmass

MACHINE TIME:
N/A

FILE/DIRECTORY:

I:\PRODUCT_CATALOG\2014 SS\ESC-1418.idw

LATHAM
INTERNATIONAL

TOLERANCES EXCEPT
AS NOTED
0/0 0.0 0.00 0.000 0'
±1/8 ±0.25 ±0.0625 ±0.03125 ±1/2'

MATERIAL:
14 GA. GALVANIZED

DATE : 4/4/2014

NOTES:

DRAWN BY: TS

SHEET : 12 OF 14

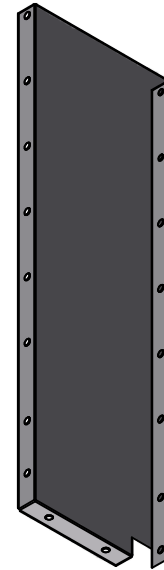
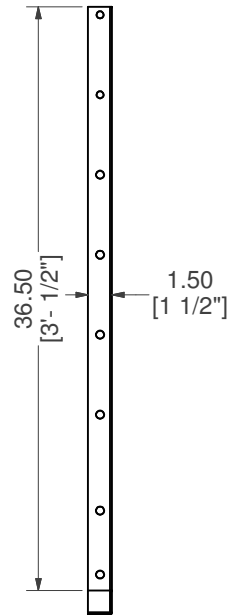
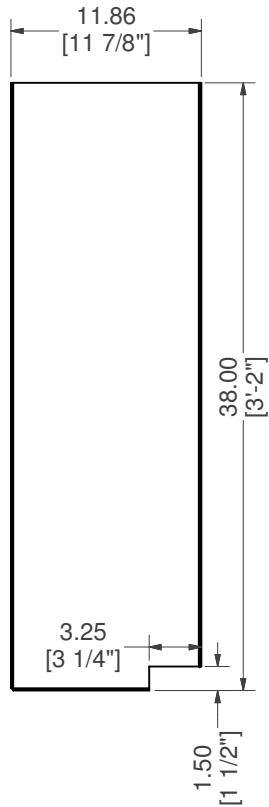
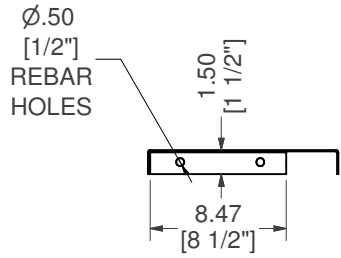

BRACE, 38" X 11.86" TOP RISER SUPPORT

PART #: ESC-1418-TBR

WEIGHT:
11.32 lbmass

MACHINE TIME:
N/A

FILE/DIRECTORY:

I:\PRODUCT_CATALOG\2014 SS\ESC-1418.idw

LATHAM
INTERNATIONAL

TOLERANCES EXCEPT
AS NOTED

0/0 0.0 0.00 0.000 0'

$\pm 1/8$ ± 0.25 ± 0.0625 ± 0.03125 $\pm 1/2'$

MATERIAL:
14 GA. GALVANIZED

DATE: 4/4/2014

NOTES:

DRAWN BY: TS

SHEET: 13 OF 14

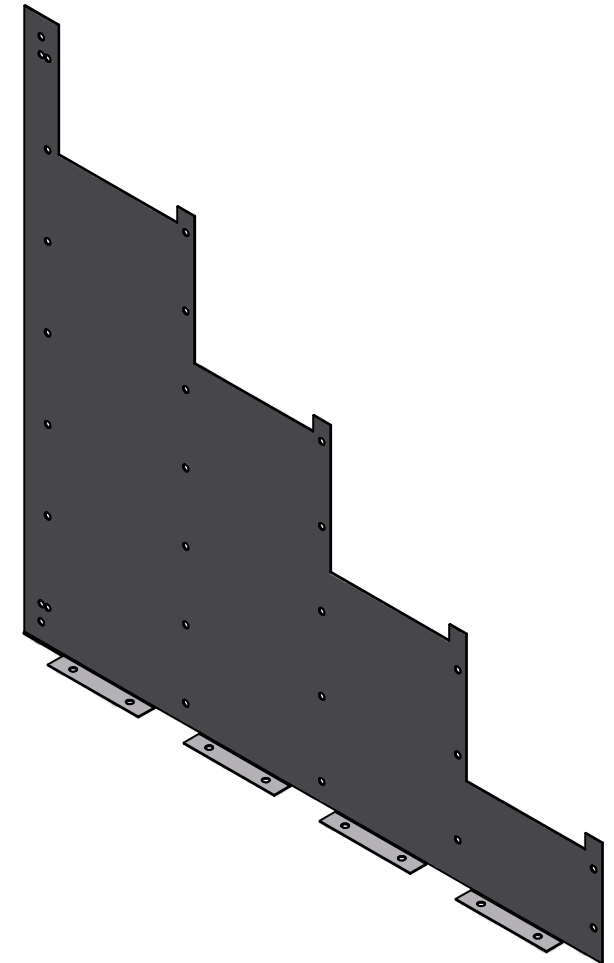
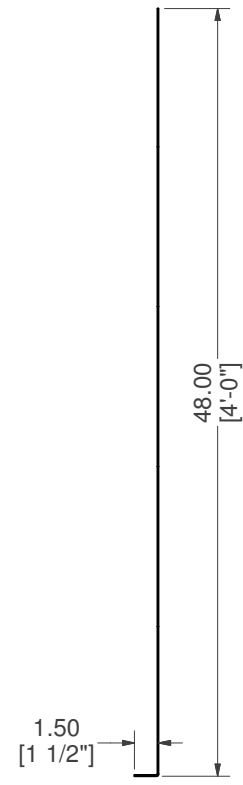
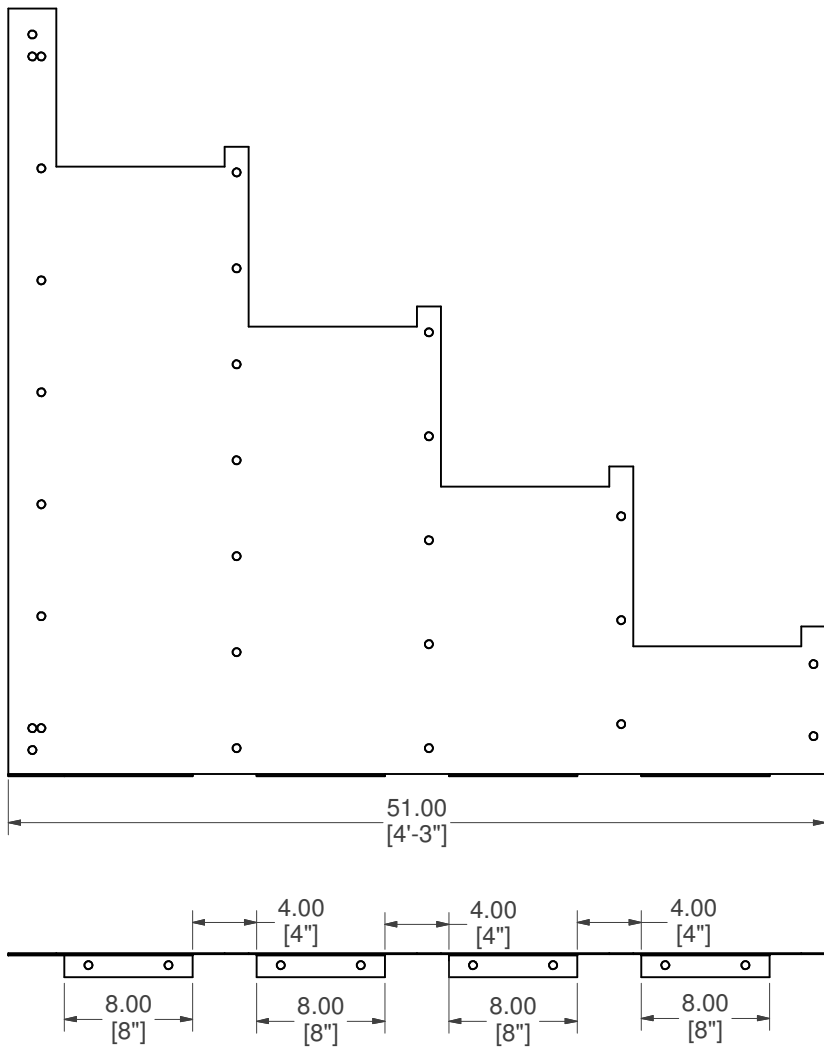

BRACE, 48" X 53" RISER SUPPORT

PART #: ESC-1418-RSB 	WEIGHT: 26.33 lbmass	MACHINE TIME: N/A	FILE/DIRECTORY: I:\PRODUCT_CATALOG\2014 SS\ESC-1418.idw
	TOLERANCES EXCEPT AS NOTED 0/0 0.0 0.00 0.000 0' ±1/8 ±0.25 ±0.0625 ±0.03125 ±1/2'	MATERIAL: 14 GA. GALVANIZED	DATE : 4/4/2014
DRAWN BY: TS	SHEET : 14 OF 14		