

Parts List

| ITEM | QTY | PART NUMBER | DESCRIPTION |
|------|-----|----------------|---------------------------------------|
| 1 | 5 | 48-Z-RIB | 48" Z-RIB |
| 2 | 59 | COP-KCVRET-W-1 | COP COPING STIFFNER 1 5/8"-1PC |
| 3 | 1 | ESC-17295-TRS | BRACE, TOP RISER SUPPORT |
| 4 | 1 | ESC-17632-BR | STRAIGHT, BOTTOM RISER |
| 5 | 1 | ESC-17632-BW | STRAIGHT, BACK WALL |
| 6 | 1 | ESC-17632-BWCR | RADIUS, BACK WALL, CORNER RIGHT |
| 7 | 1 | ESC-17632-CSB | BRACE, 3-RISER SUPPORT |
| 8 | 2 | ESC-17632-MR | STRAIGHT, MIDDLE RISER |
| 9 | 1 | ESC-17632-SBS | BRACE, SUNLEDGE BACK SUPPORT |
| 10 | 1 | ESC-17632-SNRE | STRAIGHT, SUNLEDGE RISER, END |
| 11 | 1 | ESC-17632-SRTR | STR REV, TOP RISER |
| 12 | 1 | ESC-17632-SWL | STRAIGHT, SIDE WALL, LEFT |
| 13 | 1 | ESC-17632-SWR | STRAIGHT, SIDE WALL, RIGHT |
| 14 | 1 | ESC-17632-TR | STRAIGHT, TOP RISER |
| 15 | 1 | ESC-17632-TRL | STRAIGHT, TOP RISER, LEFT |
| 16 | 1 | ESC-17632-TRS | BRACE, TOP RISER SUPPORT |
| 17 | 4 | ESC-9545-BB | BRACE, 90° L BRACKET |
| 18 | 5 | ESC-9545-BUB | BRACE, SUNLEDGE RISER ANGLE SUPPORT |
| 19 | 1 | ESC-9545-BWCL | RADIUS, BACK WALL, CORNER LEFT |
| 20 | 2 | ESC-9545-BWL | STRAIGHT, OPN BACK WALL, LEFT |
| 21 | 2 | ESC-9545-CB | BRACE, CENTER SUPPORT |
| 22 | 1 | ESC-9545-CB1 | BRACE, CENTER SUPPORT |
| 23 | 2 | ESC-9545-PT | BRACE, FLAT PLATE |
| 24 | 1 | ESC-9545-SNMR | REV RAD, SUNLEDGE RISER, MIDDLE RIGHT |
| 25 | 2 | ESC-9545-SNMS | BRACE, SUNLEDGE RISER MIDDLE SUPPORT |
| 26 | 1 | ESC-9545-SNRE | RADIUS, SUNLEDGE RISER, END |
| 27 | 1 | ESC-9545-SNRL | RADIUS, SUNLEDGE RISER, LEFT |
| 28 | 2 | ESC-9545-SNRM | REV RAD, SUNLEDGE RISER, MIDDLE |
| 29 | 5 | ESC-9545-SNRS | BRACE, SUNLEDGE RISER SUPPORT |
| 30 | 18' | OPC-CONREC-XX | NOTCHED CONCRETE RECEPTOR |
| 31 | 28' | OPC-CONREC-XXU | UN-NOTCHED CONCRETE RECEPTOR |
| 32 | 48' | SSC-1099-PFT | STEEL STEP PVC BEAD RETAINER (PER FT) |

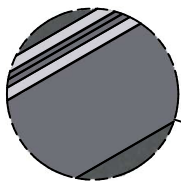

BEAD RECEIVER DETAIL

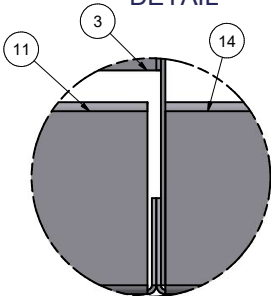

TOP VIEW
BRACE CONNECTED TO INSIDE FLANGE OF THE LEFT RISER

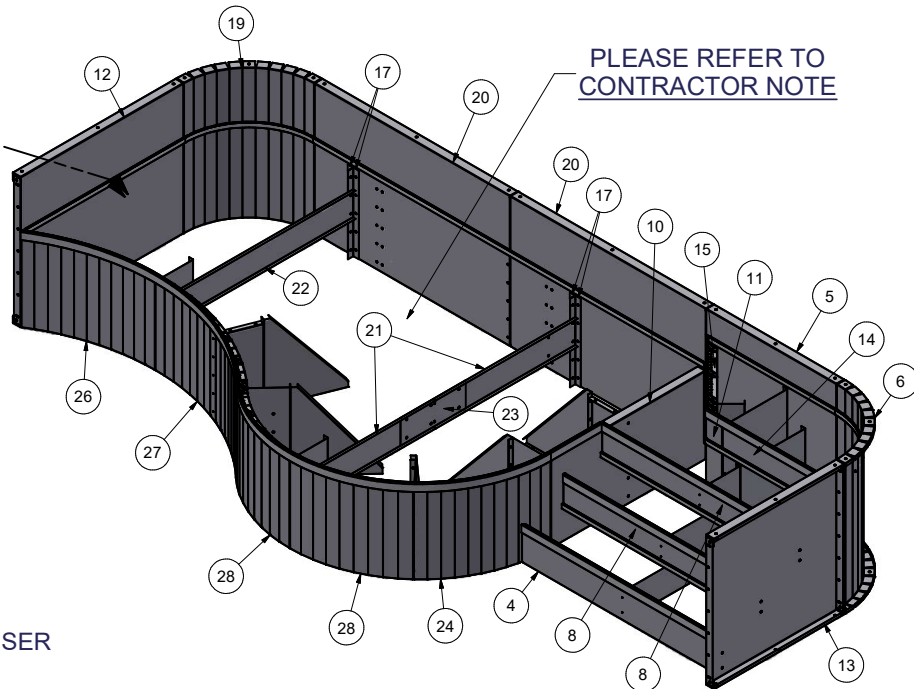

PLEASE REFER TO CONTRACTOR NOTE

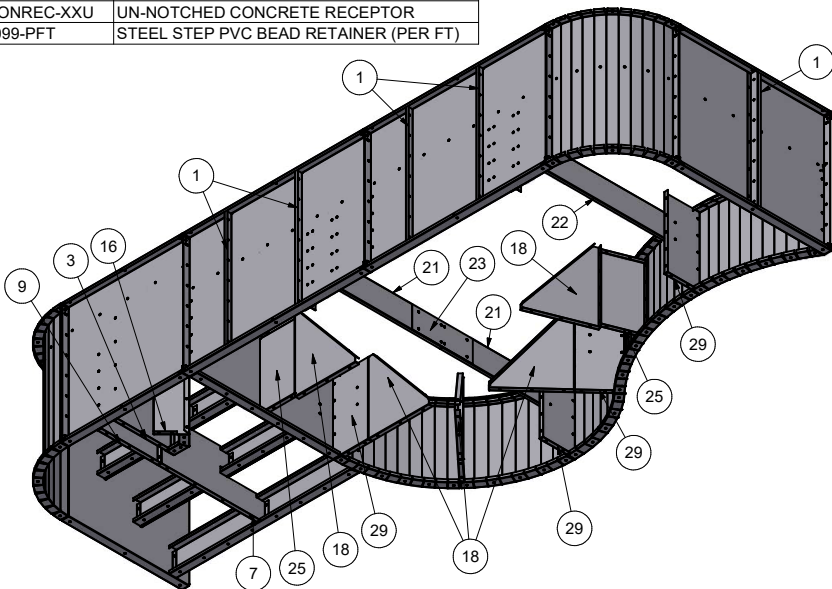

CONTRACTOR NOTE:

CONTRACTOR IS RESPONSIBLE FOR SECURING ALL RISERS INTO PLACE WITH REBAR HOLES BEFORE BACKFILLING THIS CUSTOM STEP

KEEP BEAD RECEIVER ATTACHED TO THE RISERS AND WALL PANELS FOR SHIPPING. A TOTAL OF 576" (48') OF BEAD RECEIVER IS REQUIRED.

CONTRACTOR MUST FIELD FIT ALL CONCRETE RECEPTOR.

TOTALS REQUIRED FOR THIS CUSTOM PRODUCT APPLICATION.

OPC-CONREC-XX (NOTCHED) = 216" (18')

OPC-CONREC-XXU (UN-NOTCHED) = 336" (28')

COP-KCVRET-W-1 (STIFFENER) = 59

CONTRACTOR NOTE:

BACK FILL STEP/ SUNLEDGE AREA WITH COMPACTED EARTH MATERIAL. FINISH STEP/ SUNLEDGE AREA WITH 2" OF HARDEN FLOOR MATERIAL TO MATCH REQUIRED DEPTH (FLUSH WITH TOP OF BEAD RECEIVER).

20' X 8'-9" X 2'R CRN OPEN TOP STEP W/ SUNLEDGE LEFT

| | | | |
|----------------------------------|--|---|---|
| PART #: ESC-17632 | WEIGHT: 1034.07 lbmass | MACHINE TIME: N/A | FILE/DIRECTORY: C:\Vault\FTWDesign\CUSTOM STEPS\ESC-17000-17999\ESC-17632.idw |
| | TOLERANCES EXCEPT AS NOTED 0/0 0.0 0.00 0.000 0' ±1/8 ±0.25 ±0.0625 ±0.03125 ±1/2" | MATERIAL: DRAWN BY: RK | DATE: 9/15/2023 SHEET: 1 OF 31 |

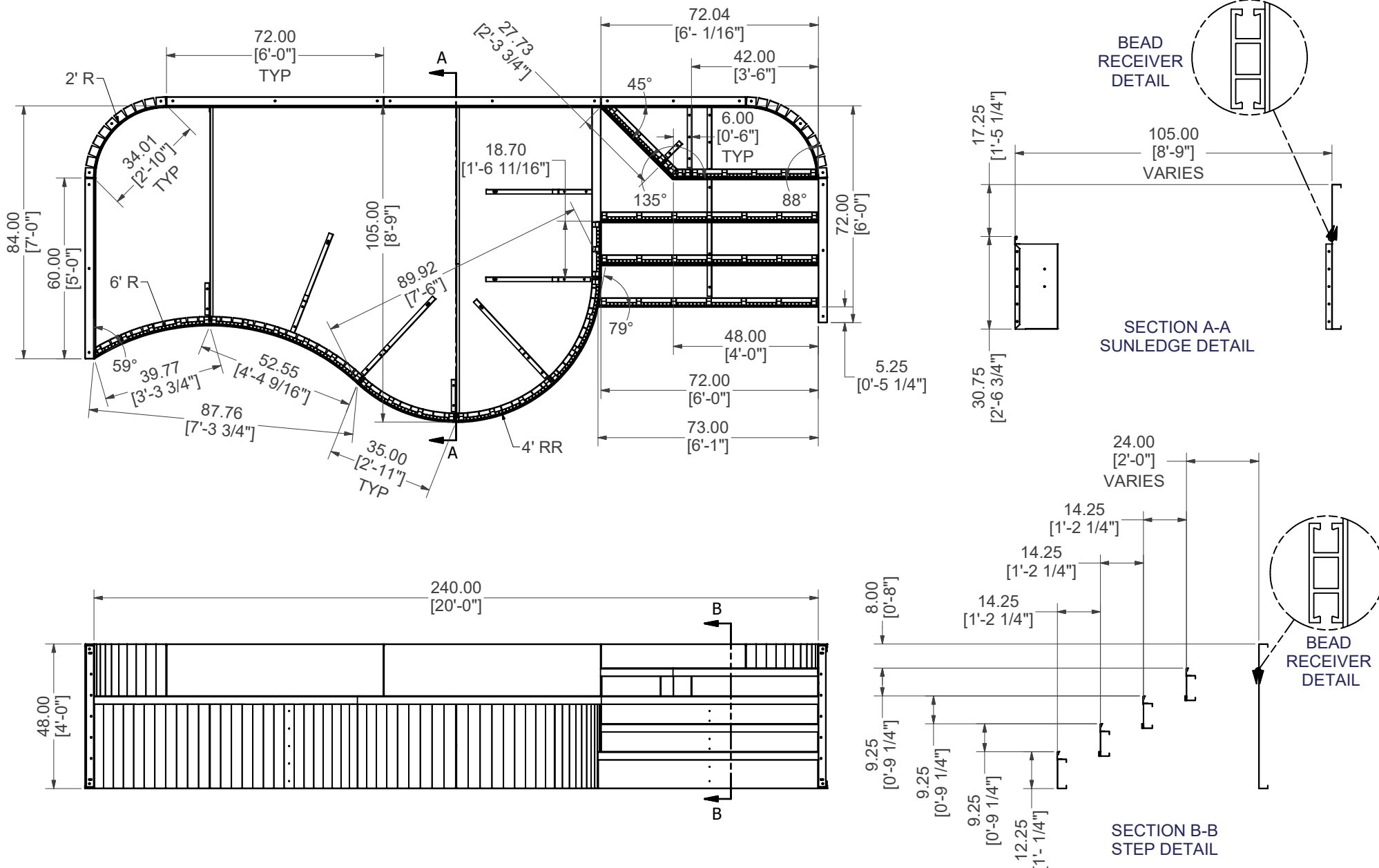

20' X 8'-9" X 2'R CRN OPEN TOP STEP W/ SUNLEDGE LEFT

| | | | |
|--------------------------|----------------------------------|--------------------------|--|
| PART #: ESC-17632 | WEIGHT: 1034.07 lbmass | MACHINE TIME: N/A | FILE/DIRECTORY: C:\Vault\FTWDesign\CUSTOM STEPS\ESC-17000-17999\ESC-17632.idw |
| | TOLERANCES EXCEPT AS NOTED | MATERIAL: | DATE: 9/15/2023 |
| | 0/0 0.0 0.00 0.000 0' | DRAWN BY: RK | NOTES: |
| | ±1/8 ±0.25 ±0.0625 ±0.03125 ±1/2 | | SHEET: 2 OF 31 |

| Parts List | | | |
|------------|-----|--------------|-------------------------------|
| ITEM | QTY | PART NUMBER | DESCRIPTION |
| 1 | 2 | 48-Z-RIB | 48" Z-RIB |
| 2 | 1 | ESC-9545-BWL | STRAIGHT, OPN BACK WALL, LEFT |

WELDCODE #46

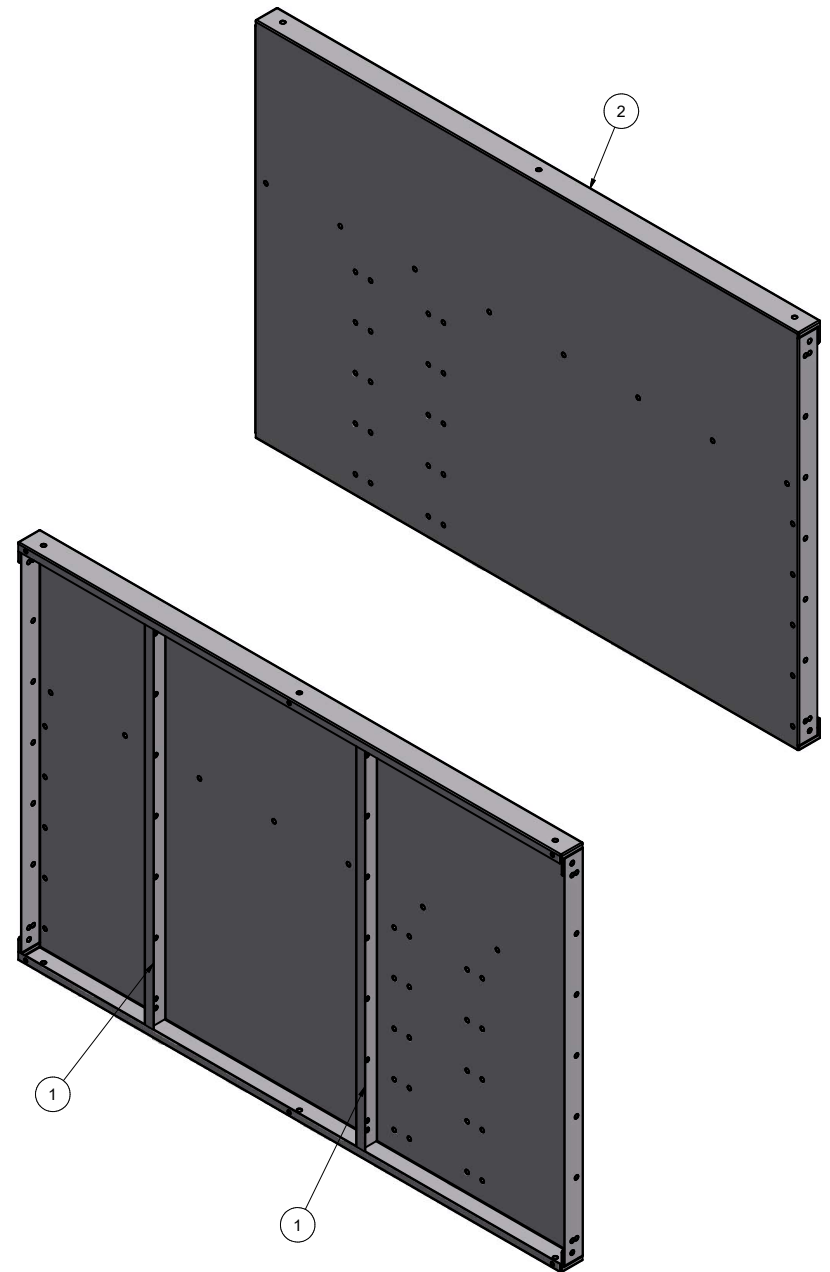
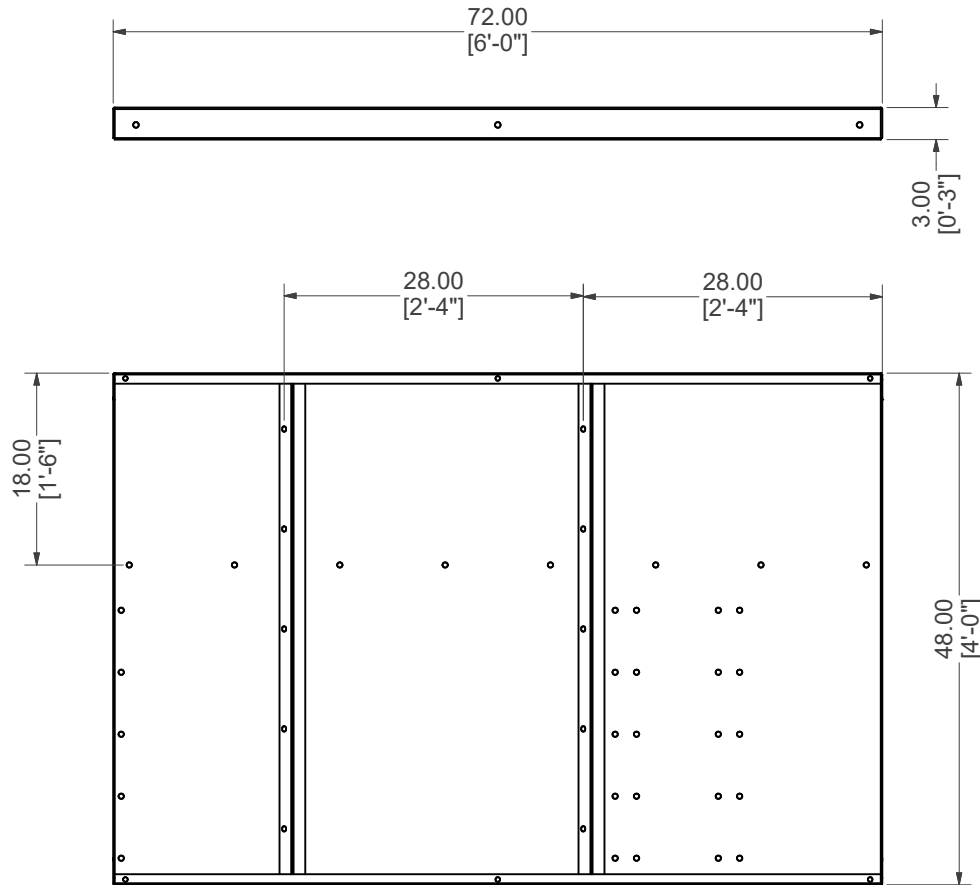

STRAIGHT, OPN BACK WALL ,LEFT W/ Z-RIBS

| | | | |
|---|--|---|---|
| PART #: ESC-9545-BWL  | WEIGHT: 95.45 lbmass | MACHINE TIME: N/A | FILE/DIRECTORY: C:\Vault\FTWDesign\CUSTOM STEPS\ESC-17000-17999\ESC-17632.idw |
| | TOLERANCES EXCEPT AS NOTED 0/0 0.0 0.00 0.000 0' ±1/8 ±0.25 ±0.0625 ±0.03125 ±1/2' | MATERIAL: DRAWN BY: RK | DATE: 9/15/2023 SHEET: 3 OF 31 |

| Parts List | | | |
|------------|-----|---------------|---------------------------|
| ITEM | QTY | PART NUMBER | DESCRIPTION |
| 1 | 1 | 48-Z-RIB | 48" Z-RIB |
| 2 | 1 | ESC-17632-SWL | STRAIGHT, SIDE WALL, LEFT |

WELDCODE #17

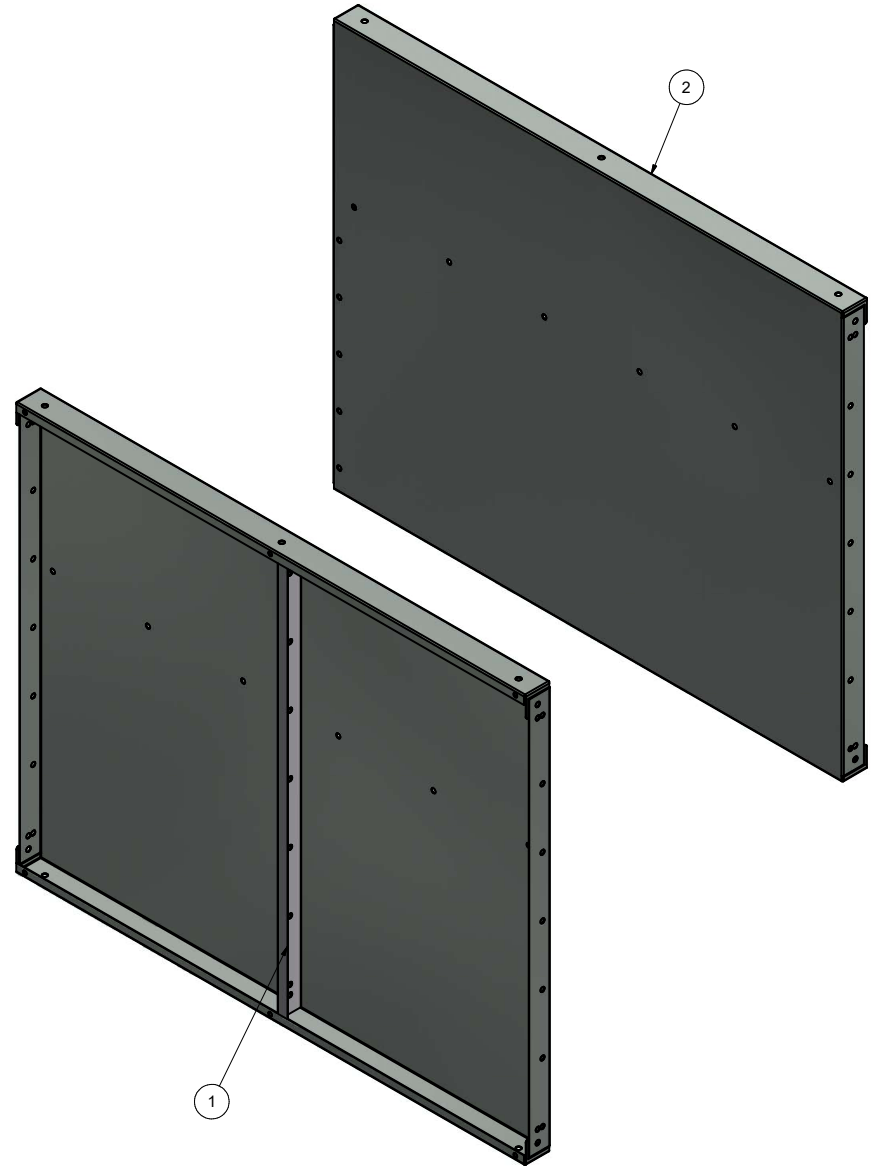
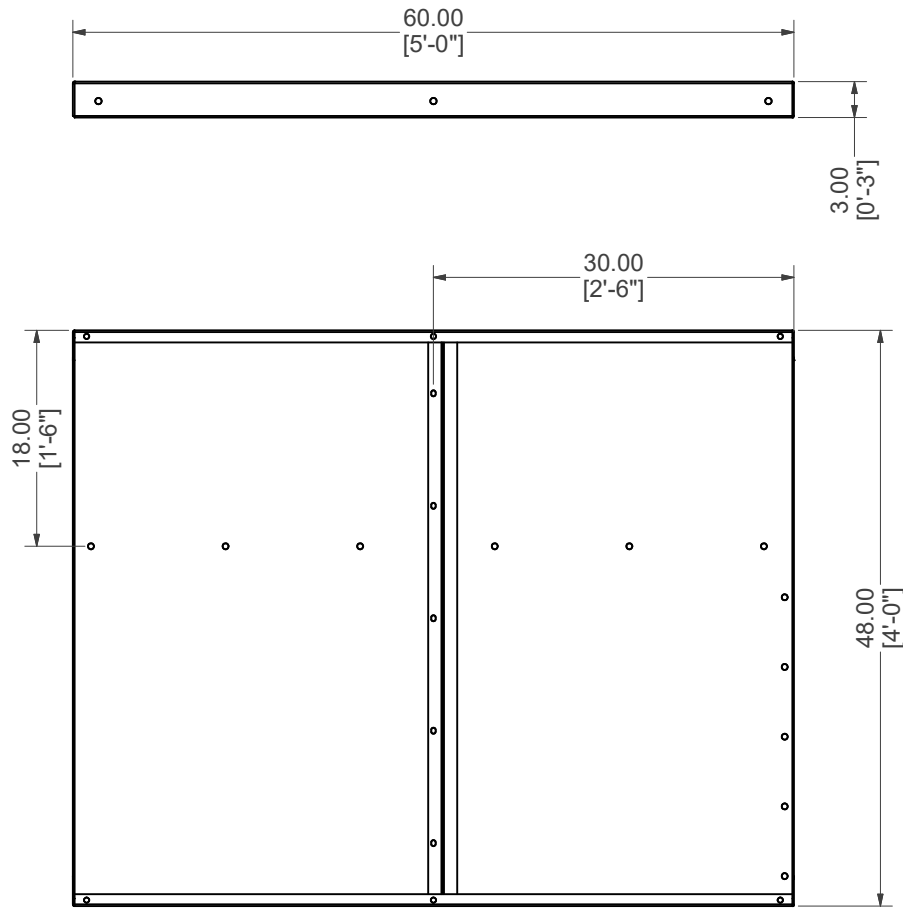

STRAIGHT, SIDE WALL, LEFT W/ Z-RIBS

| | | | |
|--|---|---|---|
| PART #: ESC-17632-SWL  | WEIGHT: 77.08 lbmass | MACHINE TIME: N/A | FILE/DIRECTORY: C:\Vault\FTWDesign\CUSTOM STEPS\ESC-17000-17999\ESC-17632.idw |
| | TOLERANCES EXCEPT AS NOTED 0/0 0.0 0.00 0.000 0' ±1/8 ±0.25 ±0.0625 ±0.03125 ±1/2" | MATERIAL: DRAWN BY: RK | DATE: 9/15/2023 SHEET: 4 OF 31 |

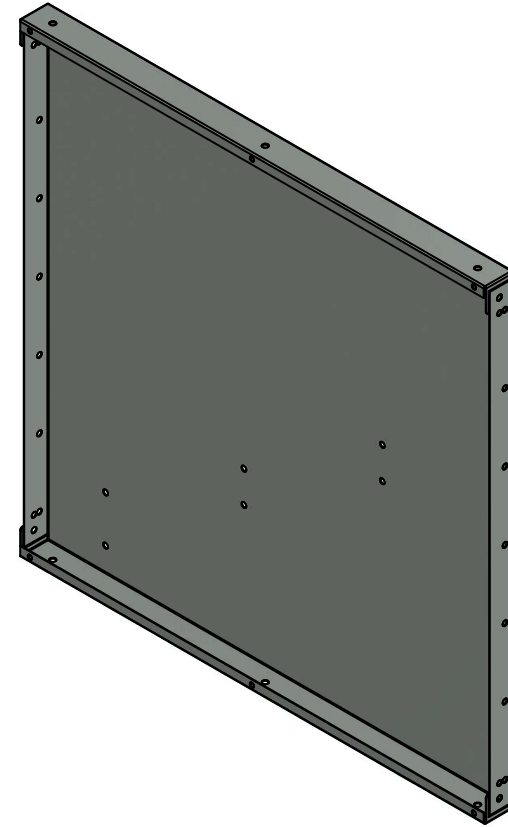
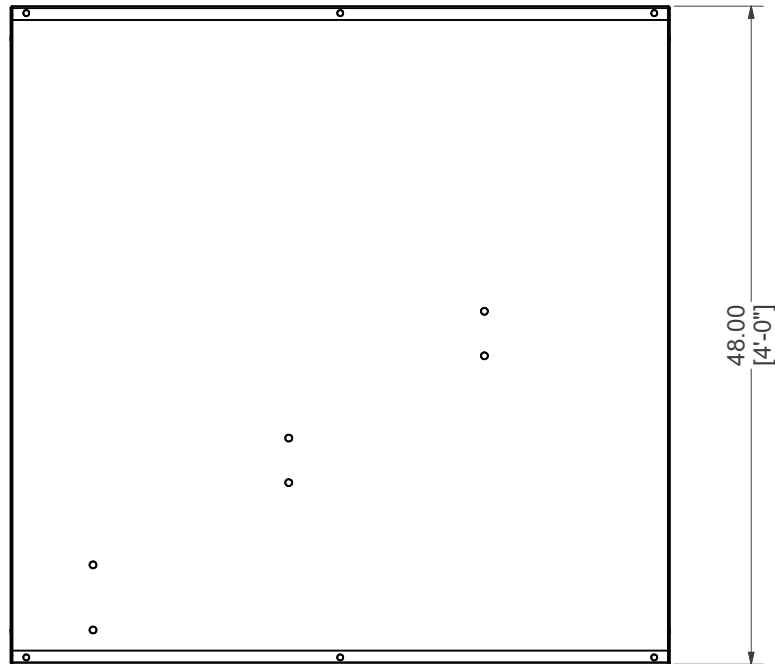
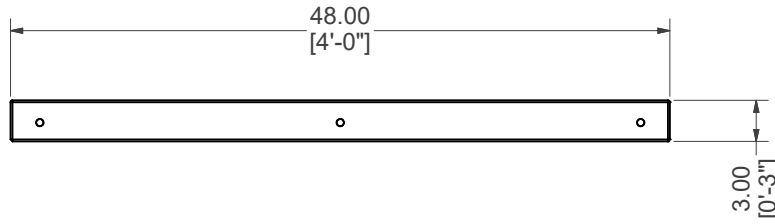

STRAIGHT, SIDE WALL, RIGHT

PART #: ESC-17632-SWR

WEIGHT:
58.64 lbmass

MACHINE TIME:
N/A

FILE/DIRECTORY:

C:\Vault\FTWDesign\CUSTOM STEPS\ESC-17000-17999\ESC-17632.idw

latham
The Pool Company

TOLERANCES EXCEPT
AS NOTED
0/0 0.0 0.00 0.000 0'
±1/8 ±0.25 ±0.0625 ±0.03125 ±1/2'

MATERIAL:
14 GA. GALVANIZED

DATE : 9/15/2023

NOTES:

DRAWN BY: RK

SHEET : 5 OF 31

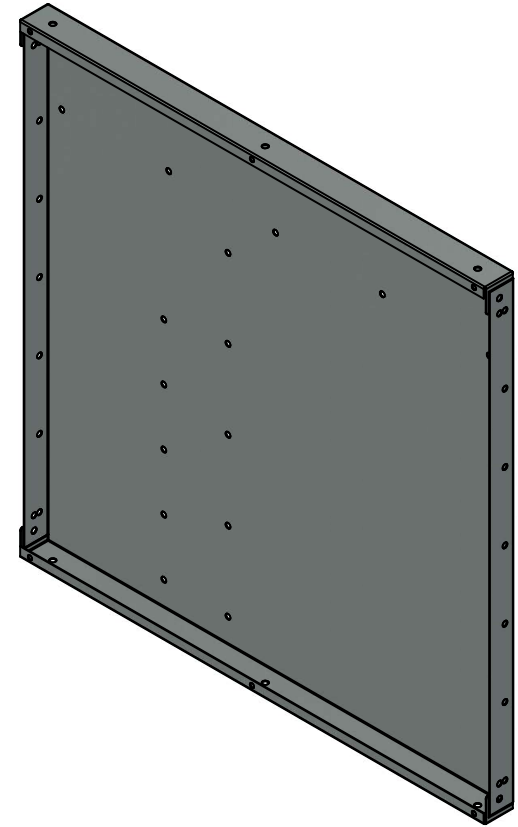
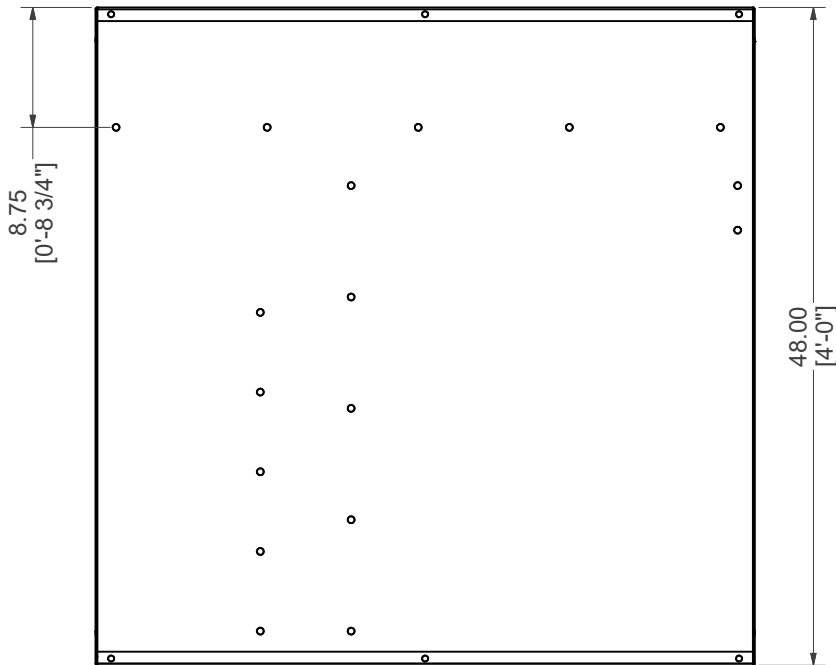
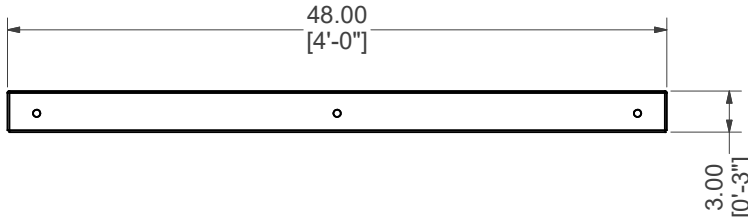

STRAIGHT, BACK WALL

PART #: ESC-17632-BW

WEIGHT:
58.60 lbmass

MACHINE TIME:
N/A

FILE/DIRECTORY:

C:\Vault\FTWDesign\CUSTOM STEPS\ESC-17000-17999\ESC-17632.idw

latham
The Pool Company

TOLERANCES EXCEPT
AS NOTED
0/0 0.0 0.00 0.000 0'
±1/8 ±0.25 ±0.0625 ±0.03125 ±1/2'

MATERIAL:
14 GA. GALVANIZED

DATE : 9/15/2023

NOTES:

DRAWN BY: RK

SHEET : 6 OF 31

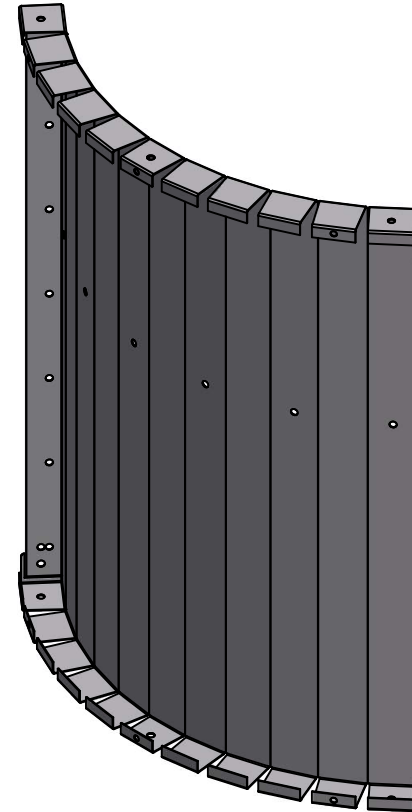
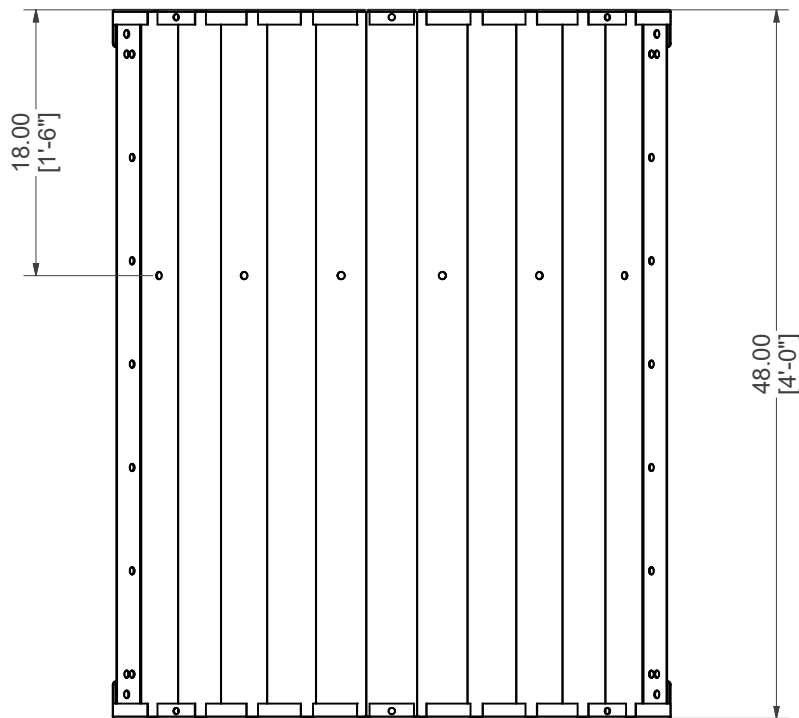
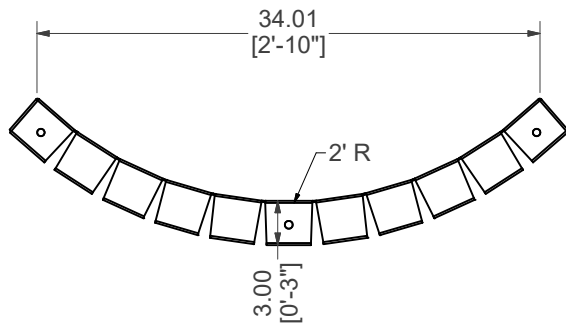

RADIUS, BACK WALL, CORNER LEFT

| | | | |
|--|--|---------------------------------------|---|
| PART #: ESC-9545-BWCL  | WEIGHT: 46.52 lbmass | MACHINE TIME: N/A | FILE/DIRECTORY: C:\Vault\FTWDesign\CUSTOM STEPS\ESC-17000-17999\ESC-17632.idw |
| | TOLERANCES EXCEPT AS NOTED 0/0 0.0 0.00 0.000 0' ±1/8 ±0.25 ±0.0625 ±0.03125 ±1/2' | MATERIAL: 14 GA. GALVANIZED | DATE : 9/15/2023 |
| DRAWN BY: RK | SHEET : 7 OF 31 | | |

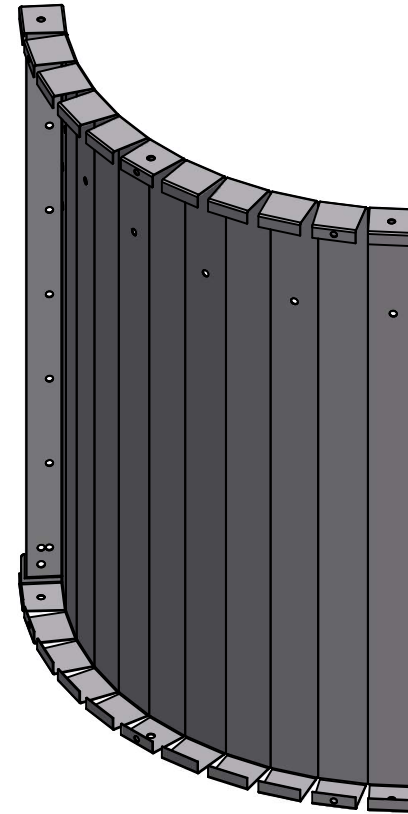
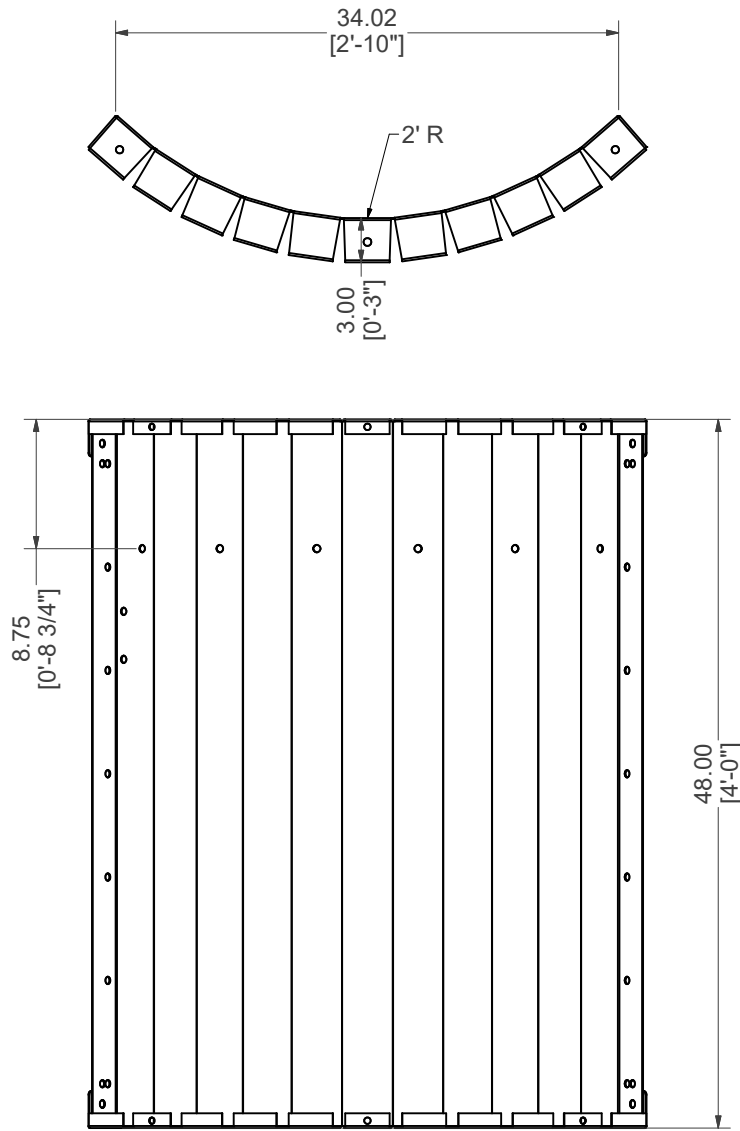

RADIUS, BACK WALL, CORNER RIGHT

PART #: ESC-17632-BWCR

WEIGHT:
46.51 lbmass

MACHINE TIME:
N/A

FILE/DIRECTORY:

C:\Vault\FTWDesign\CUSTOM STEPS\ESC-17000-17999\ESC-17632.idw

latham
The Pool Company

TOLERANCES EXCEPT
AS NOTED
0/0 0.0 0.00 0.000 0'
±1/8 ±0.25 ±0.0625 ±0.03125 ±1/2'

MATERIAL:
14 GA. GALVANIZED

DATE : 9/15/2023

NOTES:

DRAWN BY: RK

SHEET : 8 OF 31

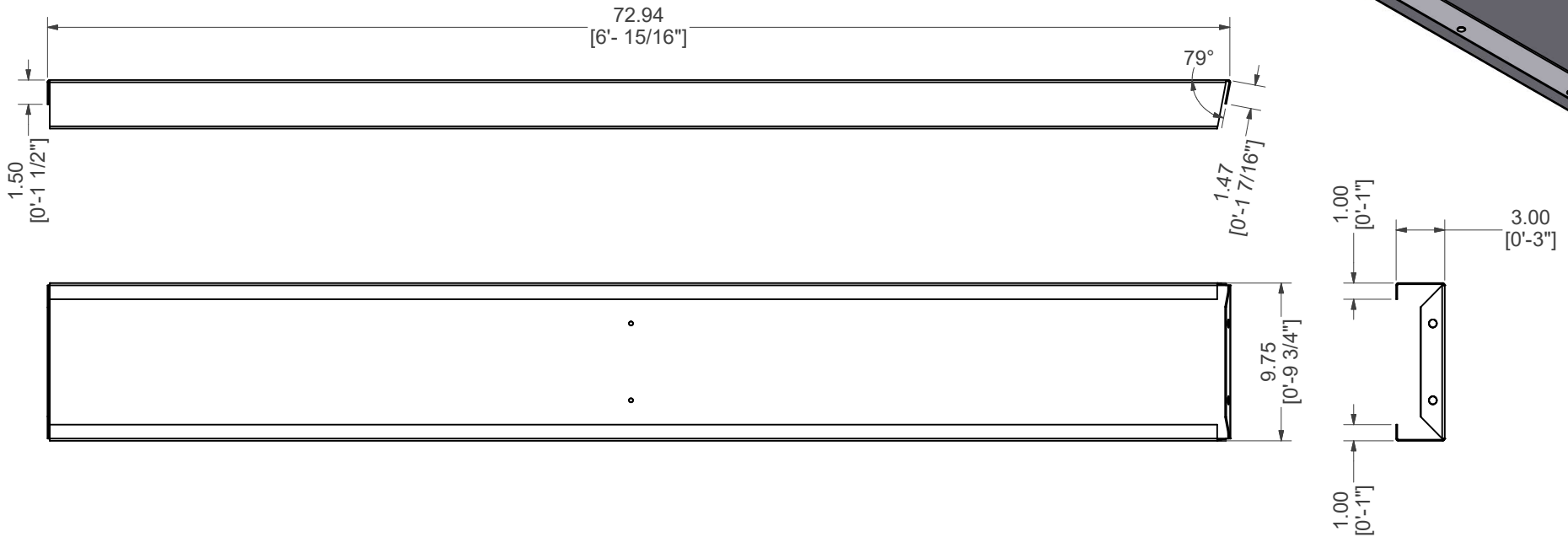
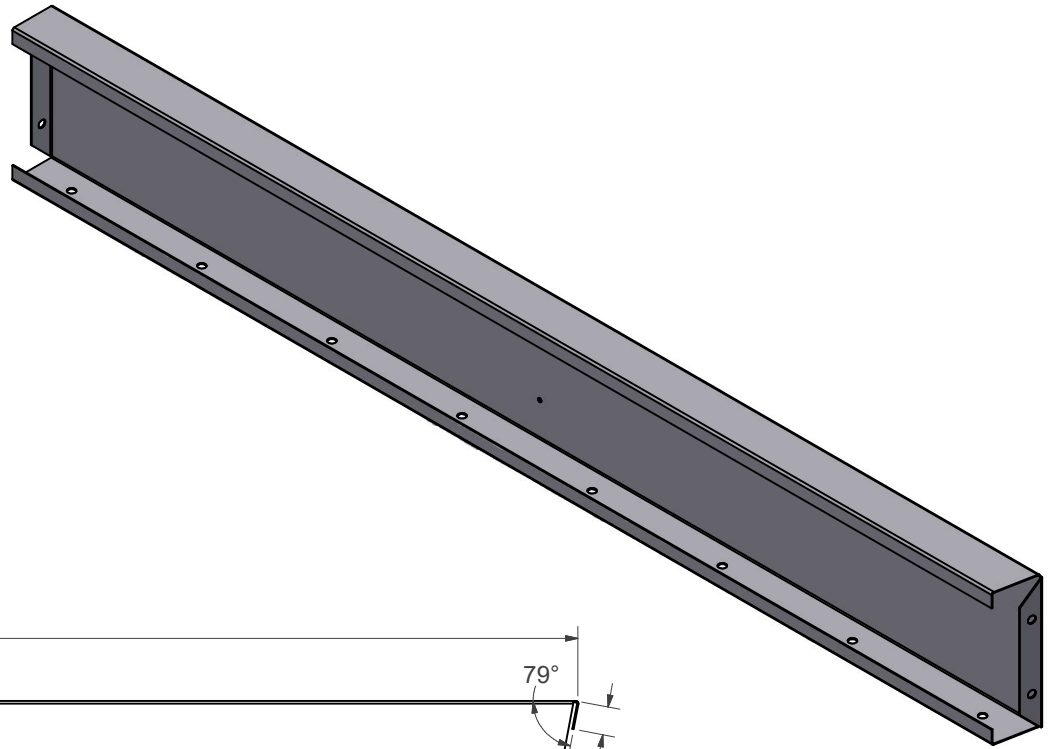

STRAIGHT, BOTTOM RISER

| | | | |
|---|---|---------------------------------------|---|
| PART #: ESC-17632-BR  | WEIGHT: 25.93 lbmass | MACHINE TIME: N/A | FILE/DIRECTORY: C:\Vault\FTWDesign\CUSTOM STEPS\ESC-17000-17999\ESC-17632.idw |
| | TOLERANCES EXCEPT AS NOTED 0/0 0.0 0.00 0.000 0' ±1/8 ±0.25 ±0.0625 ±0.03125 ±1/2' | MATERIAL: 14 GA. GALVANIZED | DATE : 9/15/2023 |
| DRAWN BY: RK | SHEET : 9 OF 31 | | |

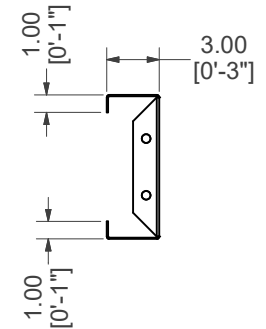
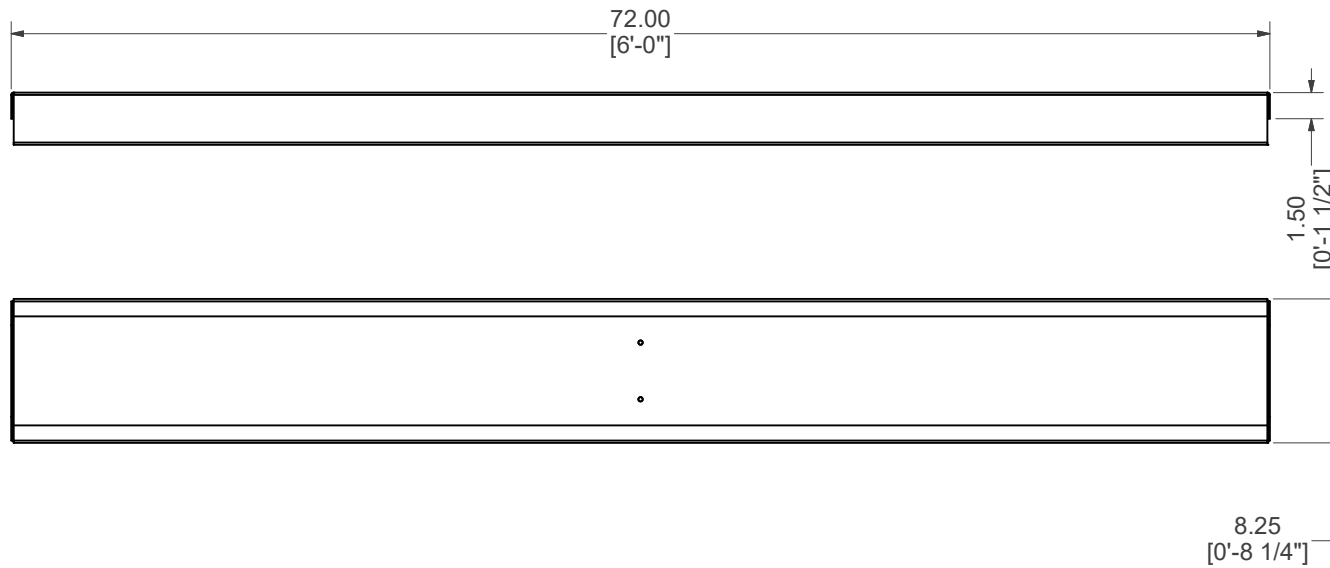
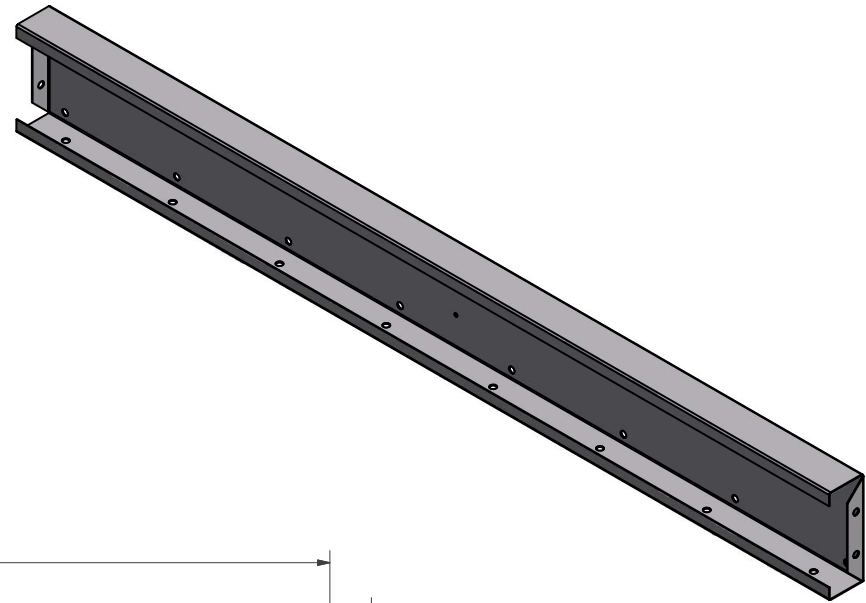

STRAIGHT, MIDDLE RISER

| | | | |
|--|--|---|---|
| PART #: ESC-17632-MR | WEIGHT: 23.35 lbmass | MACHINE TIME: N/A | FILE/DIRECTORY: C:\Vault\FTWDesign\CUSTOM STEPS\ESC-17000-17999\ESC-17632.idw |
|  | TOLERANCES EXCEPT AS NOTED 0/0 0.0 0.00 0.000 0' ±1/8 ±0.25 ±0.0625 ±0.03125 ±1/2' | MATERIAL: 14 GA. GALVANIZED DRAWN BY: RK | DATE: 9/15/2023 SHEET: 10 OF 31 |
| NOTES: | | | |

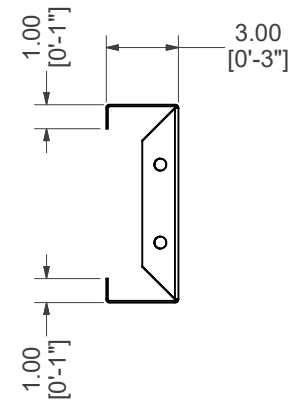
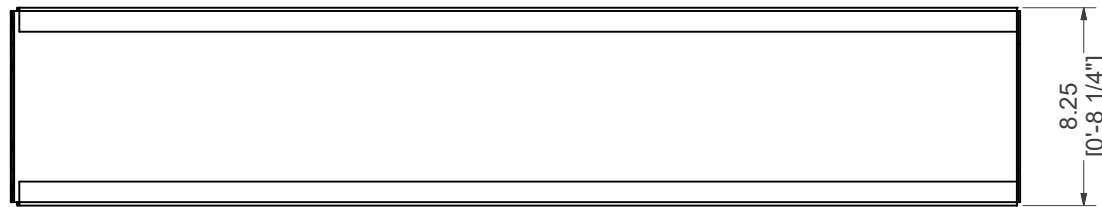
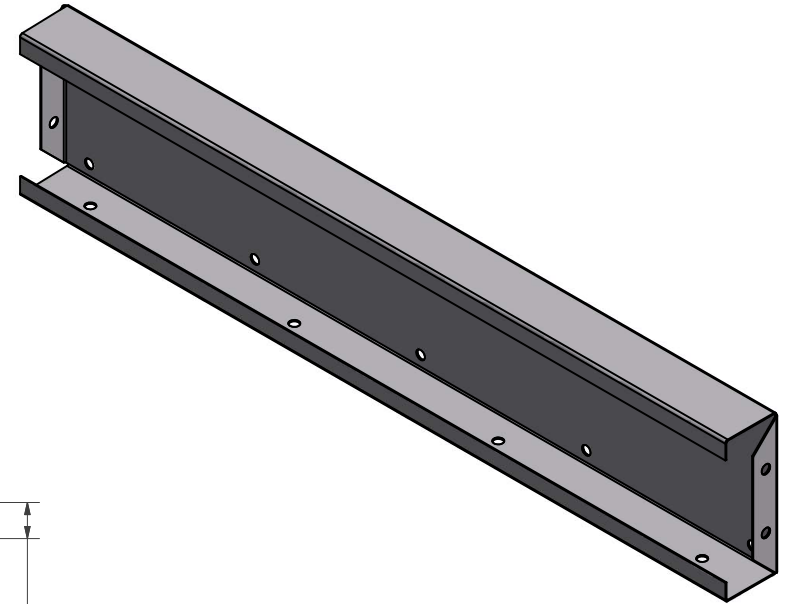
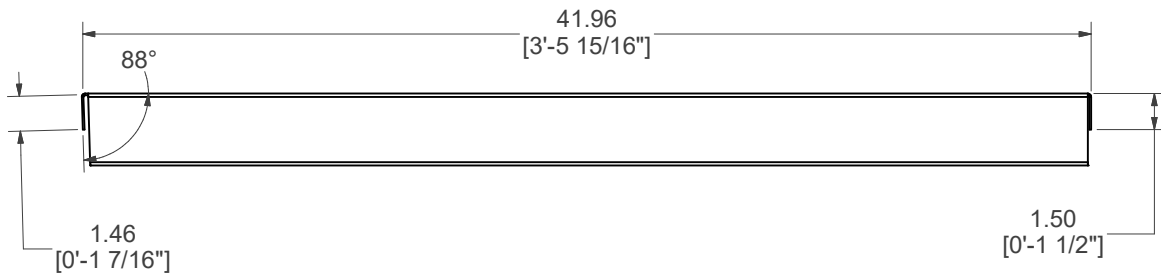

STRAIGHT, TOP RISER

| | | | |
|---|--|---------------------------------------|---|
| PART #: ESC-17632-TR  | WEIGHT: 13.72 lbmass | MACHINE TIME: N/A | FILE/DIRECTORY: C:\Vault\FTWDesign\CUSTOM STEPS\ESC-17000-17999\ESC-17632.idw |
| | TOLERANCES EXCEPT AS NOTED 0/0 0.0 0.00 0.000 0' ±1/8 ±0.25 ±0.0625 ±0.03125 ±1/2' | MATERIAL: 14 GA. GALVANIZED | DATE: 9/15/2023 |
| DRAWN BY: RK | SHEET: 11 OF 31 | | |

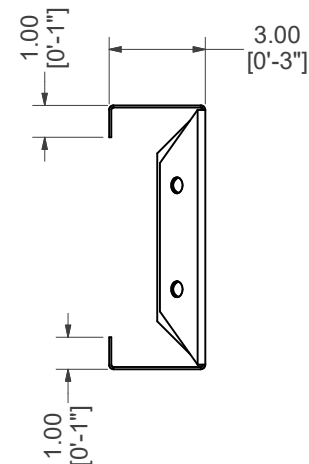
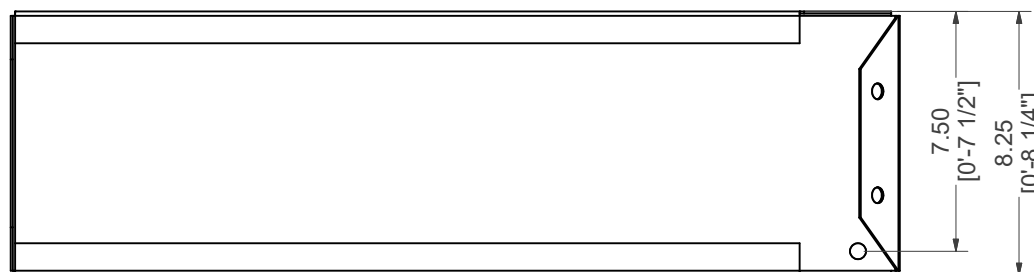
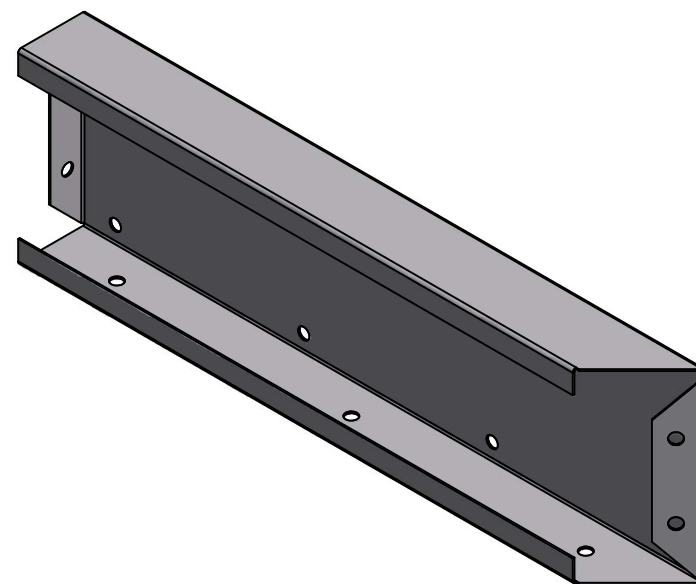
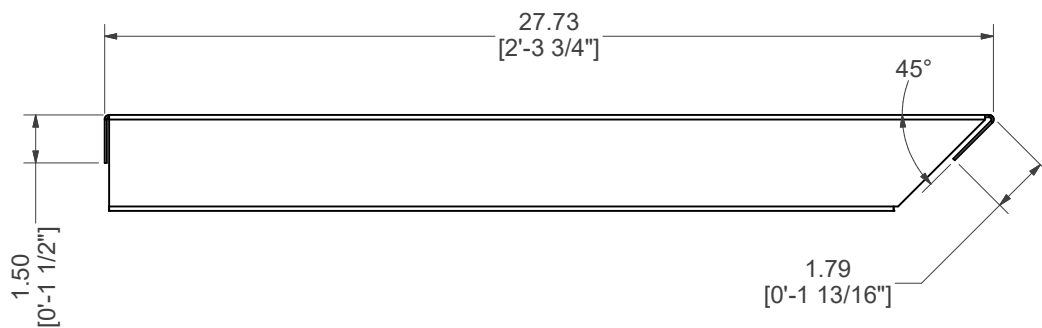

STRAIGHT, TOP RISER, LEFT

| | | | |
|--|---|---------------------------------------|--|
| PART #: ESC-17632-TRL | WEIGHT: 8.94 lbmass | MACHINE TIME: N/A | FILE/DIRECTORY: C:\Vault\FTW\Design\CUSTOM STEPS\ESC-17000-17999\ESC-17632.idw |
|  | TOLERANCES EXCEPT AS NOTED 0/0 0.0 0.00 0.000 0' ±1/8 ±0.25 ±0.0625 ±0.03125 ±1/2' | MATERIAL: 14 GA. GALVANIZED | DATE : 9/15/2023 |
| | | DRAWN BY: RK | SHEET : 12 OF 31 |
| NOTES: | | | |

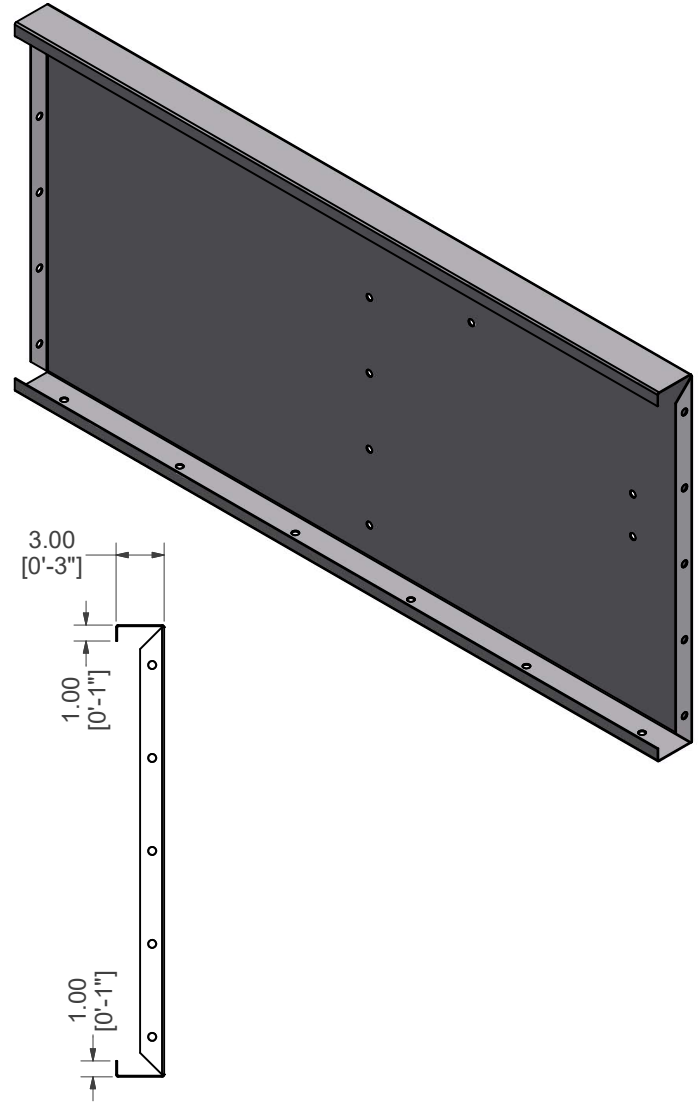
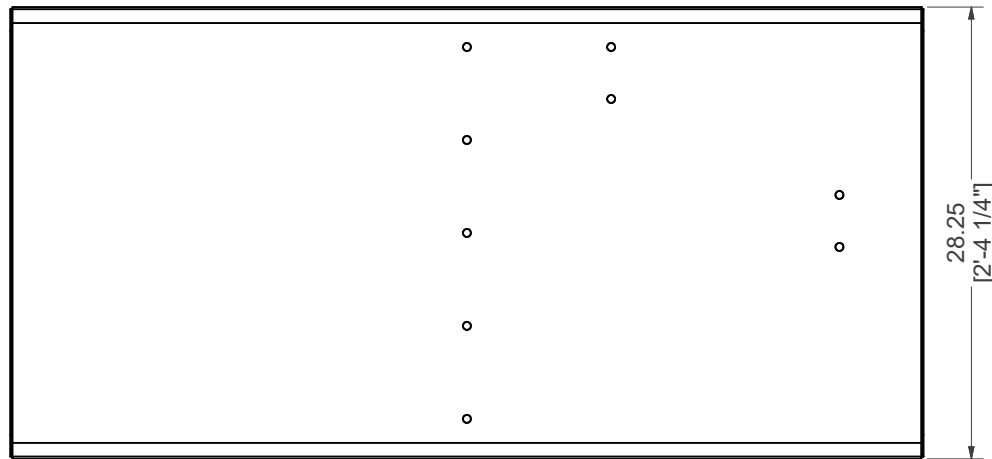
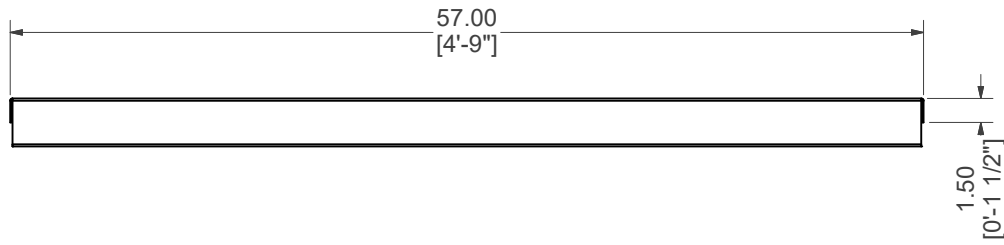

STRAIGHT, SUNLEDGE RISER, END

PART #: ESC-17632-SNRE

WEIGHT:
42.80 lbmass

MACHINE TIME:
N/A

FILE/DIRECTORY:

C:\Vault\FTWDesign\CUSTOM STEPS\ESC-17000-17999\ESC-17632.idw

latham
The Pool Company

TOLERANCES EXCEPT
AS NOTED
0/0 0.0 0.00 0.000 0'
±1/8 ±0.25 ±0.0625 ±0.03125 ±1/2'

MATERIAL:
14 GA. GALVANIZED

DATE : 9/15/2023

NOTES:

DRAWN BY: RK

SHEET : 13 OF 31

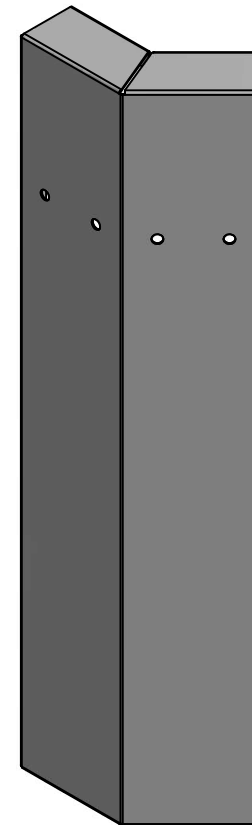
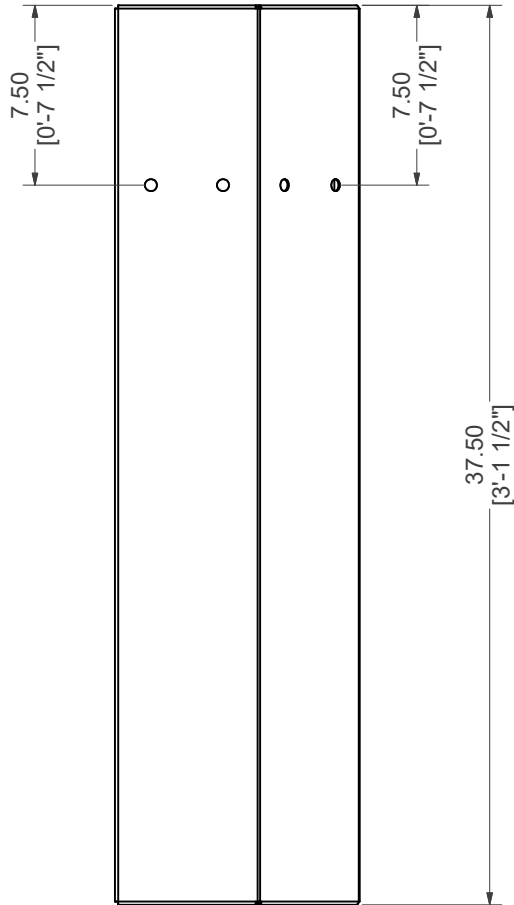
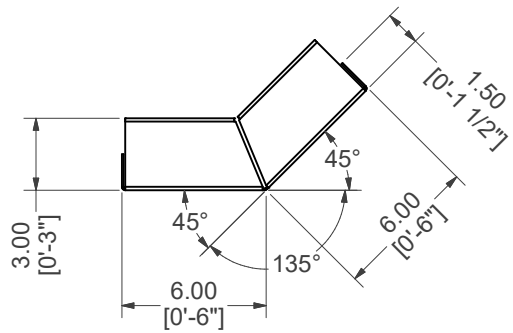

STR REV, TOP RISER

| | | | |
|---|--|---------------------------------------|---|
| PART #: ESC-17632-SRTR  | WEIGHT: 12.59 lbmass | MACHINE TIME: N/A | FILE/DIRECTORY: C:\Vault\FTWDesign\CUSTOM STEPS\ESC-17000-17999\ESC-17632.idw |
| | TOLERANCES EXCEPT AS NOTED 0/0 0.0 0.00 0.000 0' ±1/8 ±0.25 ±0.0625 ±0.03125 ±1/2' | MATERIAL: 14 GA. GALVANIZED | DATE : 9/15/2023 |
| DRAWN BY: RK | SHEET : 14 OF 31 | | |

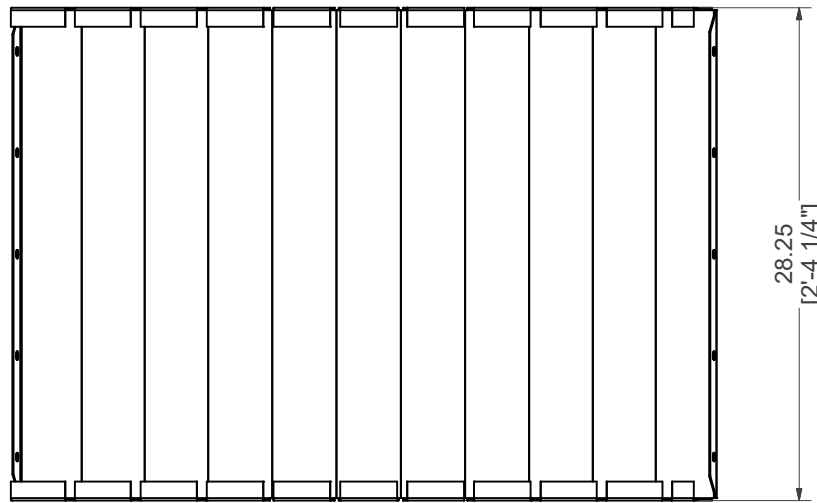
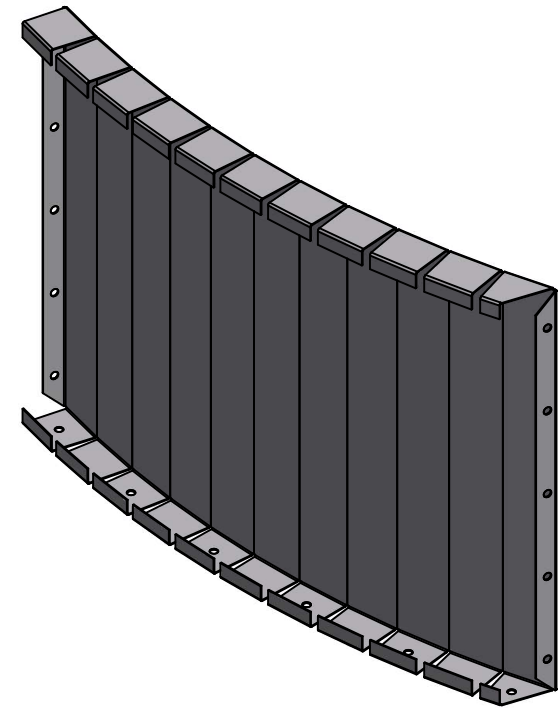
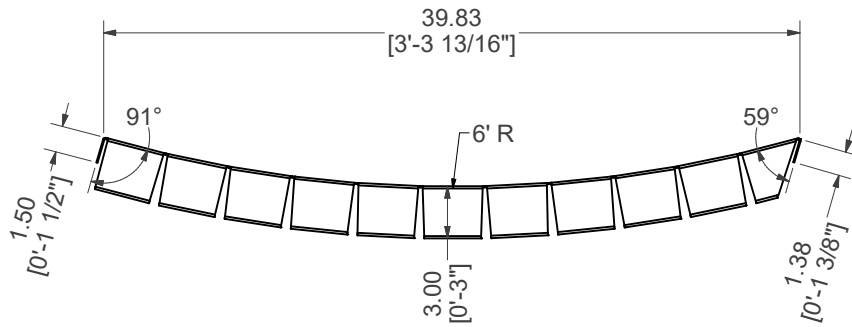

RADIUS, SUNLEDGE RISER, END

| | | | |
|--|--|---------------------------------------|---|
| PART #: ESC-9545-SNRE  | WEIGHT: 30.07 lbmass | MACHINE TIME: N/A | FILE/DIRECTORY: C:\Vault\FTWDesign\CUSTOM STEPS\ESC-17000-17999\ESC-17632.idw |
| | TOLERANCES EXCEPT AS NOTED 0/0 0.0 0.00 0.000 0' ±1/8 ±0.25 ±0.0625 ±0.03125 ±1/2' | MATERIAL: 14 GA. GALVANIZED | DATE : 9/15/2023 |
| | DRAWN BY: RK | SHEET : 15 OF 31 | |

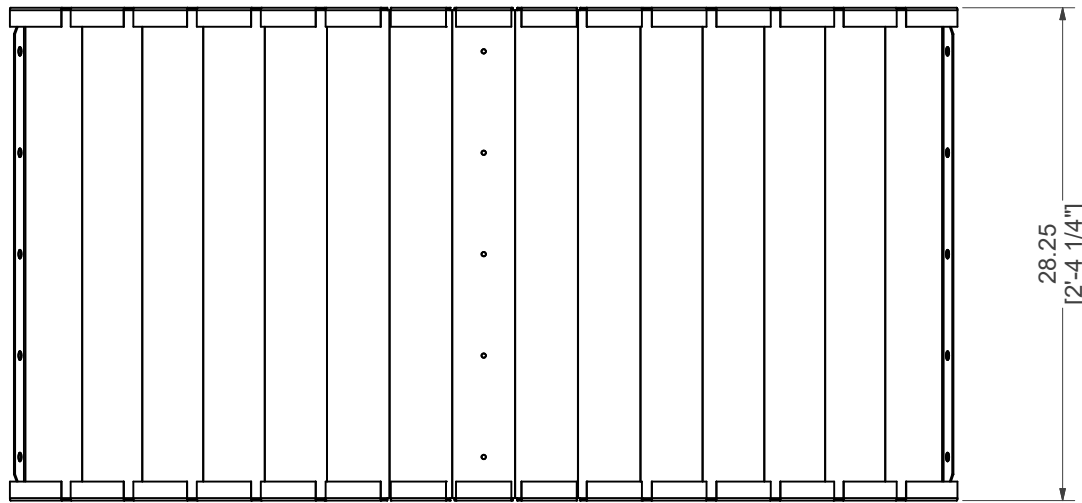
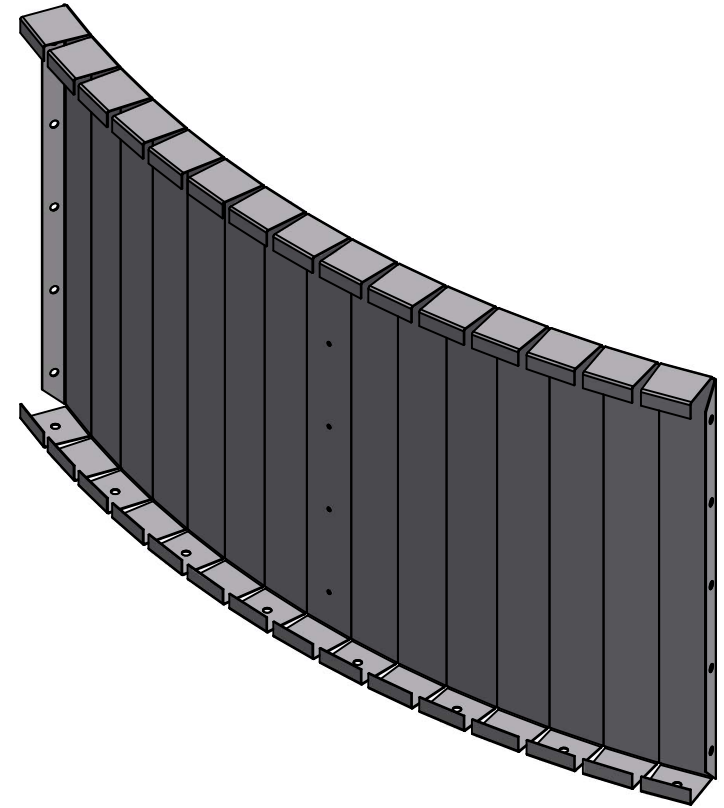
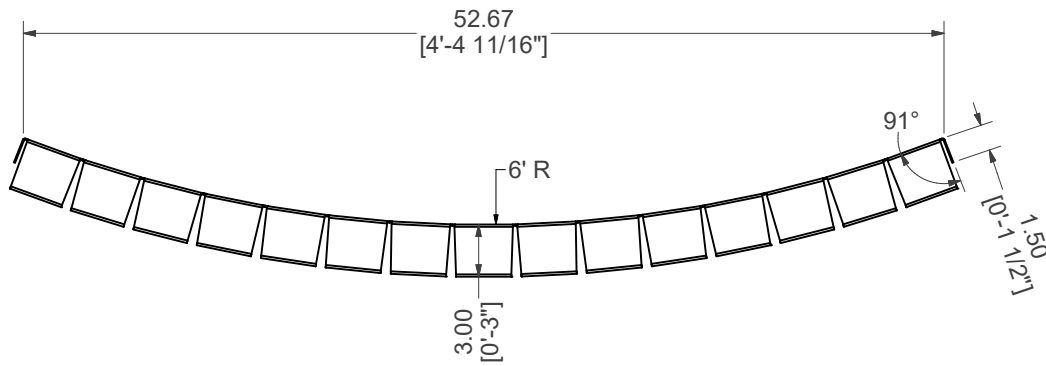

RADIUS, SUNLEDGE RISER, LEFT

| | | | |
|--|--|---------------------------------------|---|
| PART #: ESC-9545-SNRL  | WEIGHT: 39.93 lbmass | MACHINE TIME: N/A | FILE/DIRECTORY: C:\Vault\FTWDesign\CUSTOM STEPS\ESC-17000-17999\ESC-17632.idw |
| | TOLERANCES EXCEPT AS NOTED 0/0 0.0 0.00 0.000 0' ±1/8 ±0.25 ±0.0625 ±0.03125 ±1/2' | MATERIAL: 14 GA. GALVANIZED | DATE : 9/15/2023 |
| | DRAWN BY: RK | SHEET : 16 OF 31 | |

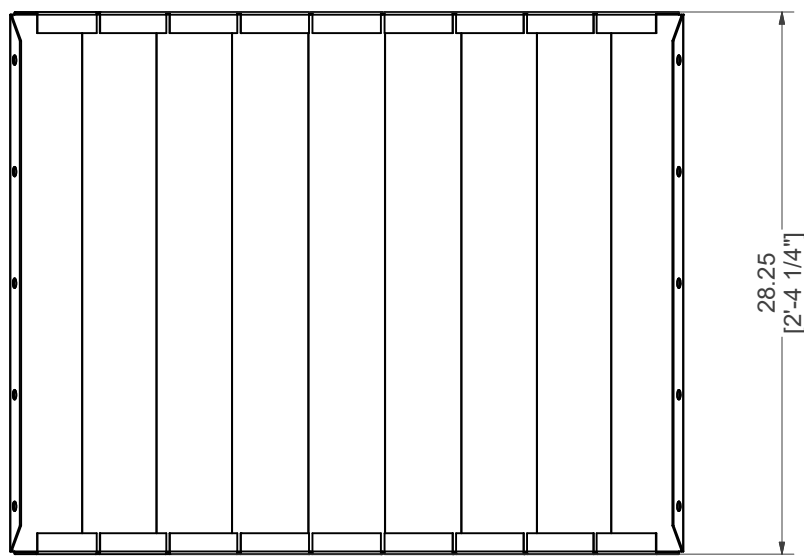
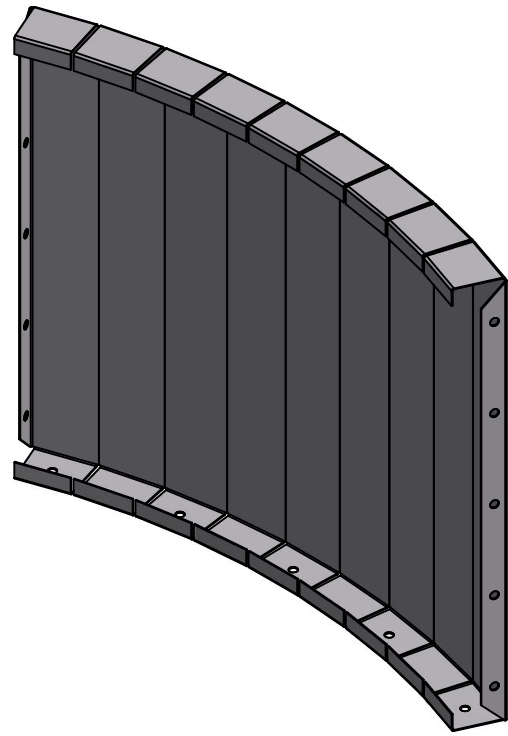
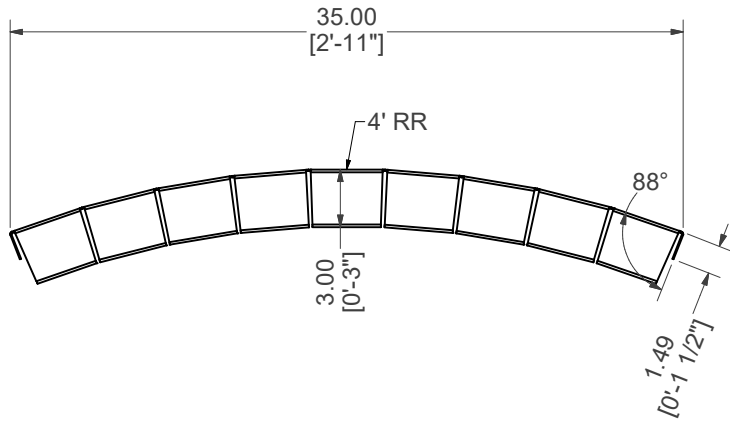

REV RAD, SUNLEDGE RISER, MIDDLE

| | | | |
|--------------------------------------|--|---------------------------------------|---|
| PART #: ESC-9545-SNRM | WEIGHT: 27.06 lbmass | MACHINE TIME: N/A | FILE/DIRECTORY: C:\Vault\FTWDesign\CUSTOM STEPS\ESC-17000-17999\ESC-17632.idw |
| | TOLERANCES EXCEPT AS NOTED 0/0 0.0 0.00 0.000 0' ±1/8 ±0.25 ±0.0625 ±0.03125 ±1/2' | MATERIAL: 14 GA. GALVANIZED | DATE : 9/15/2023 |
| | DRAWN BY: RK | SHEET : 17 OF 31 | |

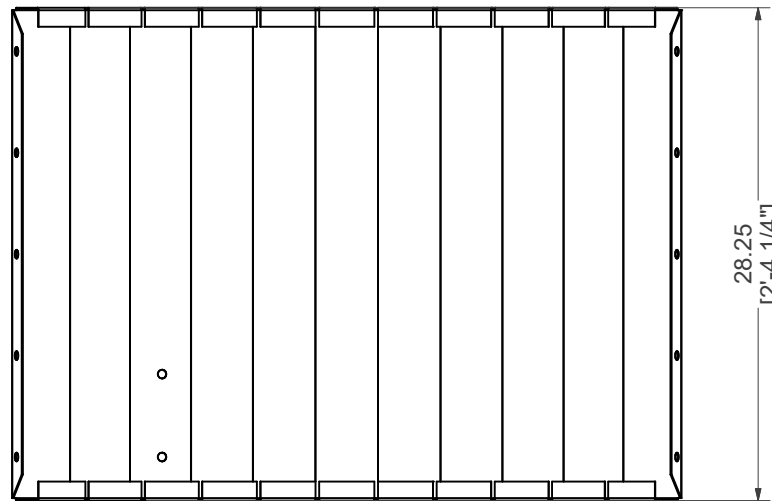
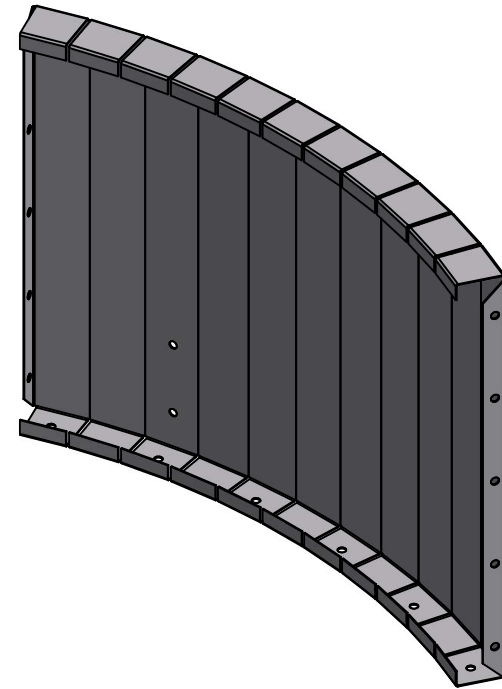
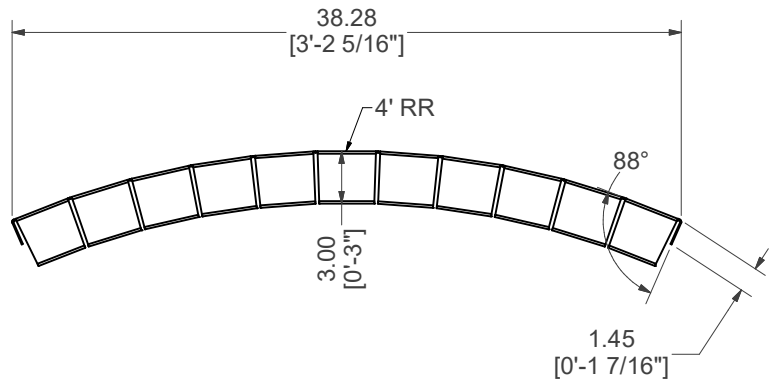

REV RAD, SUNLEDGE RISER, MIDDLE RIGHT

PART #: ESC-9545-SNMR

WEIGHT:
29.53 lbmass

MACHINE TIME:
N/A

FILE/DIRECTORY:

C:\Vault\FTWDesign\CUSTOM STEPS\ESC-17000-17999\ESC-17632.idw

latham
The Pool Company

TOLERANCES EXCEPT
AS NOTED
0/0 0.0 0.00 0.000 0'
±1/8 ±0.25 ±0.0625 ±0.03125 ±1/2'

MATERIAL:
14 GA. GALVANIZED

DATE : 9/15/2023

NOTES:

DRAWN BY: RK

SHEET : 18 OF 31

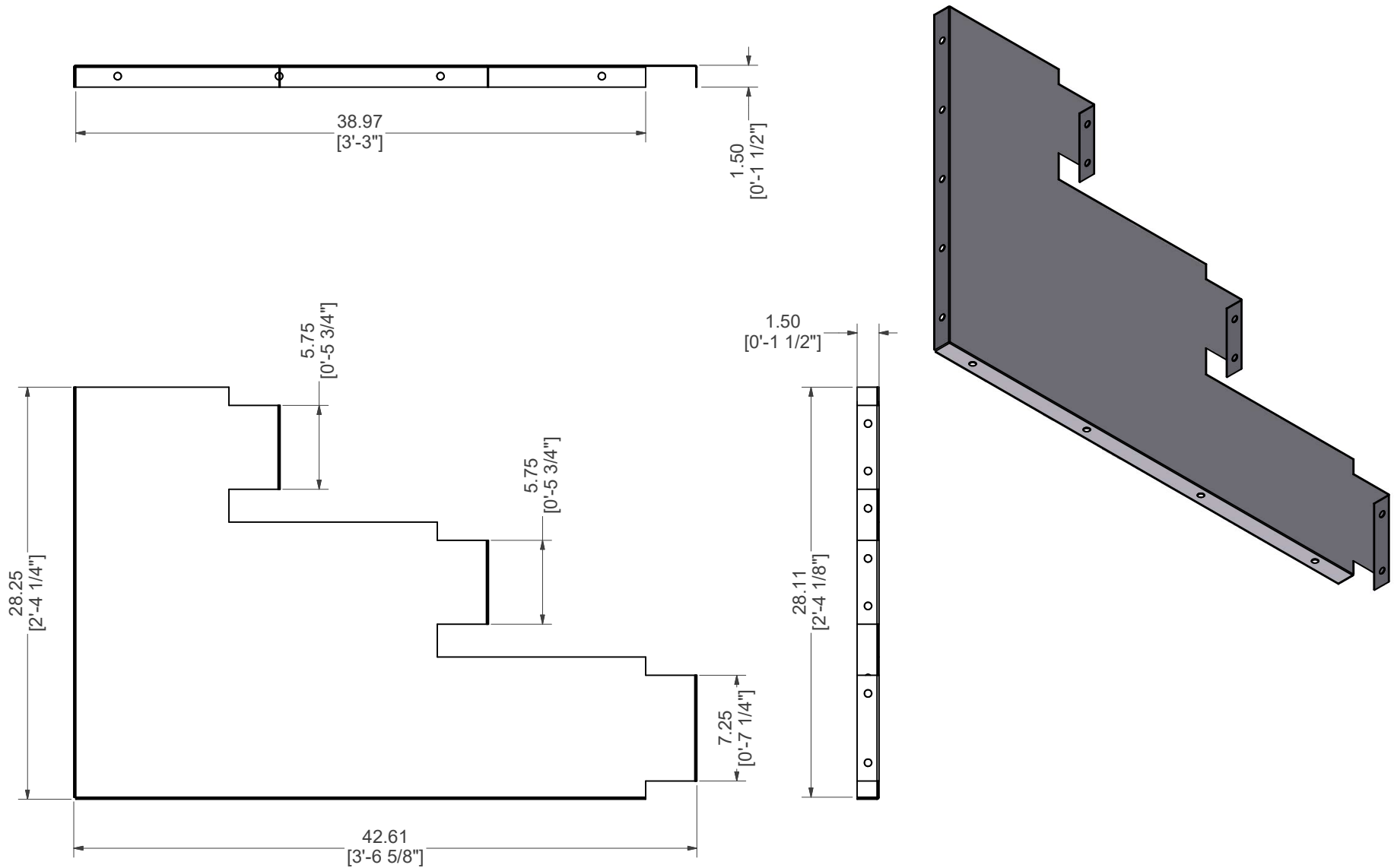

BRACE, 3-RISER SUPPORT

| | | | | |
|--|---|---------------------------------------|---|---------------|
| PART #: ESC-17632-CSB | WEIGHT: 18.10 lbmass | MACHINE TIME: N/A | FILE/DIRECTORY: C:\Vault\FTWDesign\CUSTOM STEPS\ESC-17000-17999\ESC-17632.idw | |
|  | TOLERANCES EXCEPT AS NOTED 0/0 0.0 0.00 0.000 0' ±1/8 ±0.25 ±0.0625 ±0.03125 ±1/2' | MATERIAL: 14 GA. GALVANIZED | DATE: 9/15/2023 | NOTES: |
| | | DRAWN BY: RK | SHEET: 19 OF 31 | |

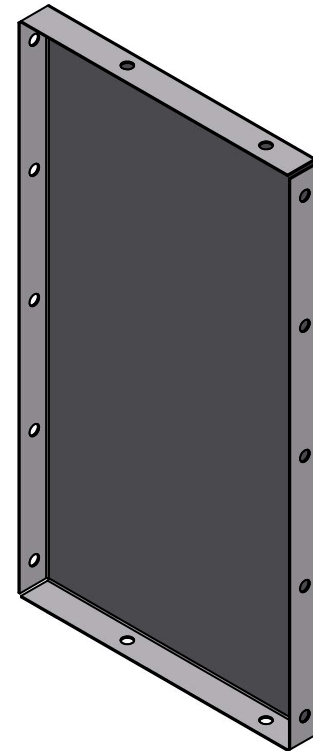
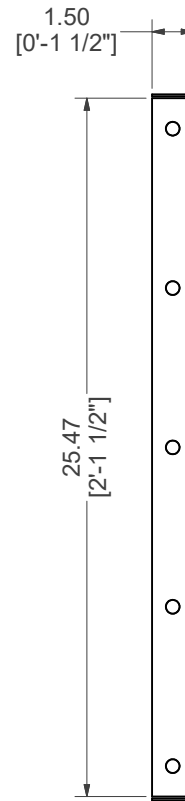
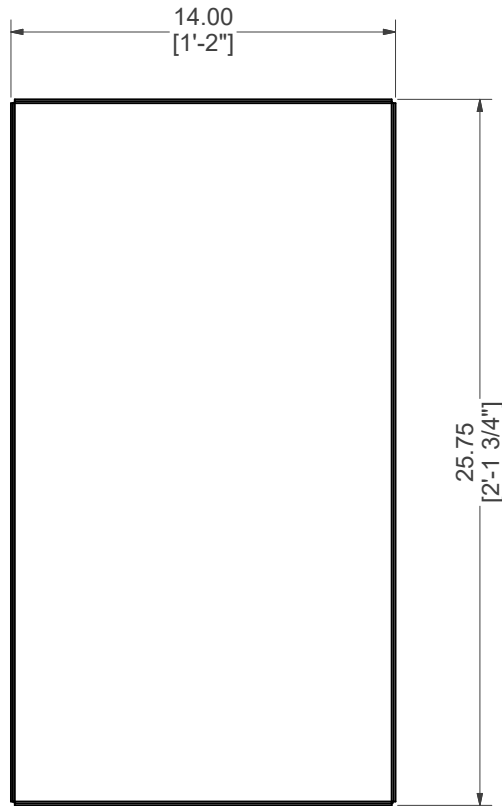
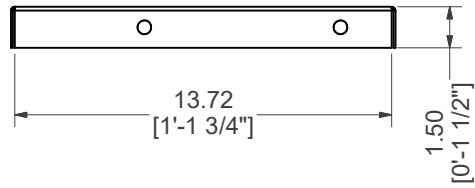

BRACE, SUNLEDGE RISER MIDDLE SUPPORT

| | | | |
|--|--|---------------------------------------|---|
| PART #: ESC-9545-SNMS  | WEIGHT: 9.47 lbmass | MACHINE TIME: N/A | FILE/DIRECTORY: C:\Vault\FTWDesign\CUSTOM STEPS\ESC-17000-17999\ESC-17632.idw |
| | TOLERANCES EXCEPT AS NOTED 0/0 0.0 0.00 0.000 0' ±1/8 ±0.25 ±0.0625 ±0.03125 ±1/2' | MATERIAL: 14 GA. GALVANIZED | DATE : 9/15/2023 |
| DRAWN BY: RK | SHEET : 20 OF 31 | | |

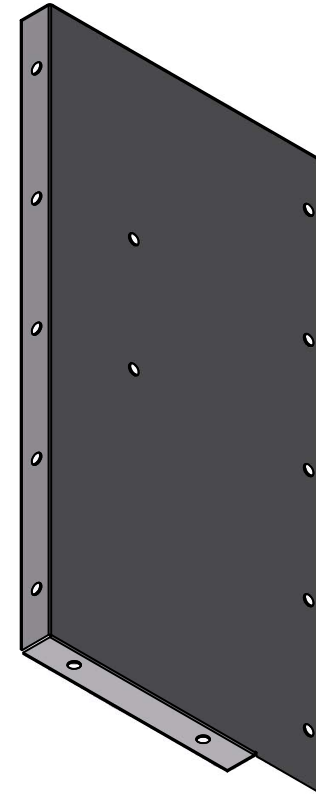
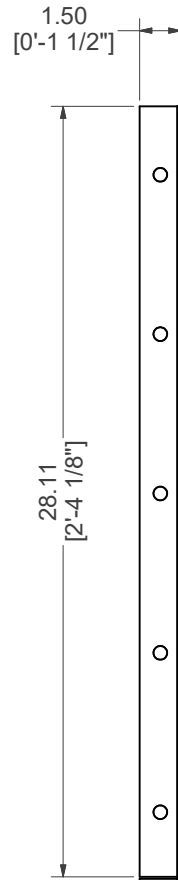
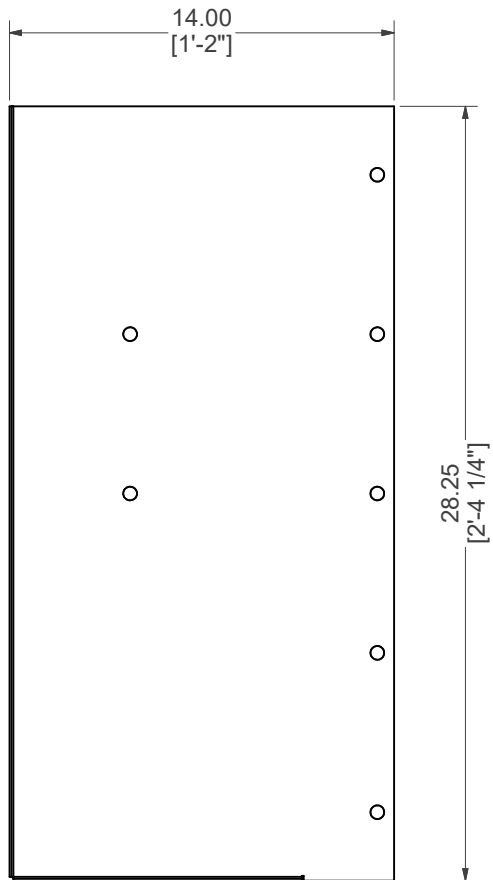
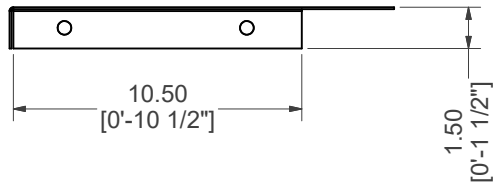

BRACE, SUNLEDGE RISER SUPPORT

| | | | |
|--|--|---------------------------------------|---|
| PART #: ESC-9545-SNRS  | WEIGHT: 9.07 lbmass | MACHINE TIME: N/A | FILE/DIRECTORY: C:\Vault\FTWDesign\CUSTOM STEPS\ESC-17000-17999\ESC-17632.idw |
| | TOLERANCES EXCEPT AS NOTED 0/0 0.0 0.00 0.000 0' ±1/8 ±0.25 ±0.0625 ±0.03125 ±1/2' | MATERIAL: 14 GA. GALVANIZED | DATE : 9/15/2023 |
| DRAWN BY: RK | SHEET : 21 OF 31 | | |

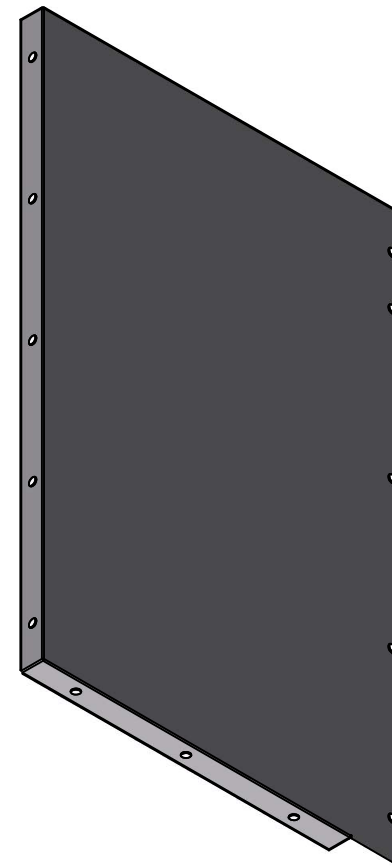
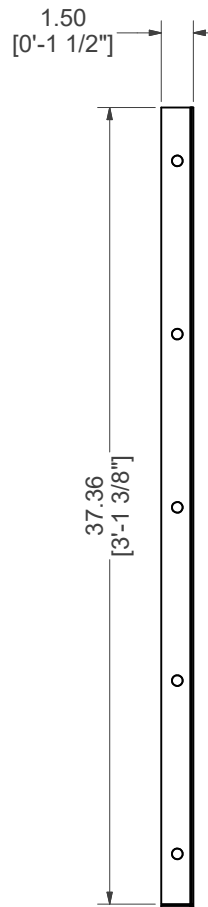
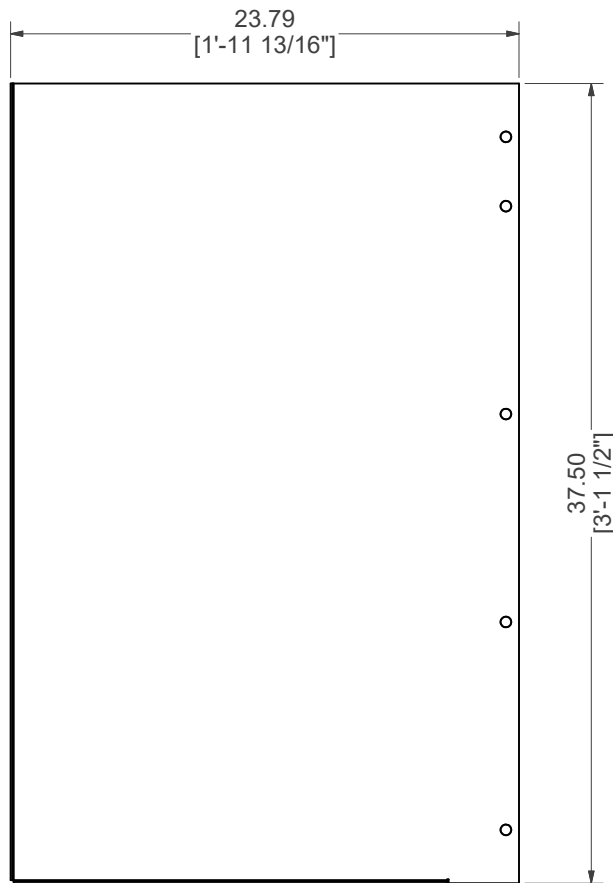
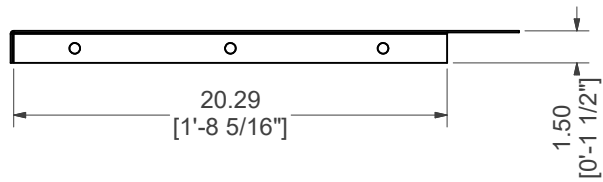

BRACE, TOP RISER SUPPORT

| | | | |
|--|---|---------------------------------------|---|
| PART #: ESC-17295-TRS  | WEIGHT: 19.70 lbmass | MACHINE TIME: N/A | FILE/DIRECTORY: C:\Vault\FTWDesign\CUSTOM STEPS\ESC-17000-17999\ESC-17632.idw |
| | TOLERANCES EXCEPT AS NOTED 0/0 0.0 0.00 0.000 0' ±1/8 ±0.25 ±0.0625 ±0.03125 ±1/2' | MATERIAL: 14 GA. GALVANIZED | DATE : 9/15/2023 |
| DRAWN BY: RK | SHEET : 22 OF 31 | | |

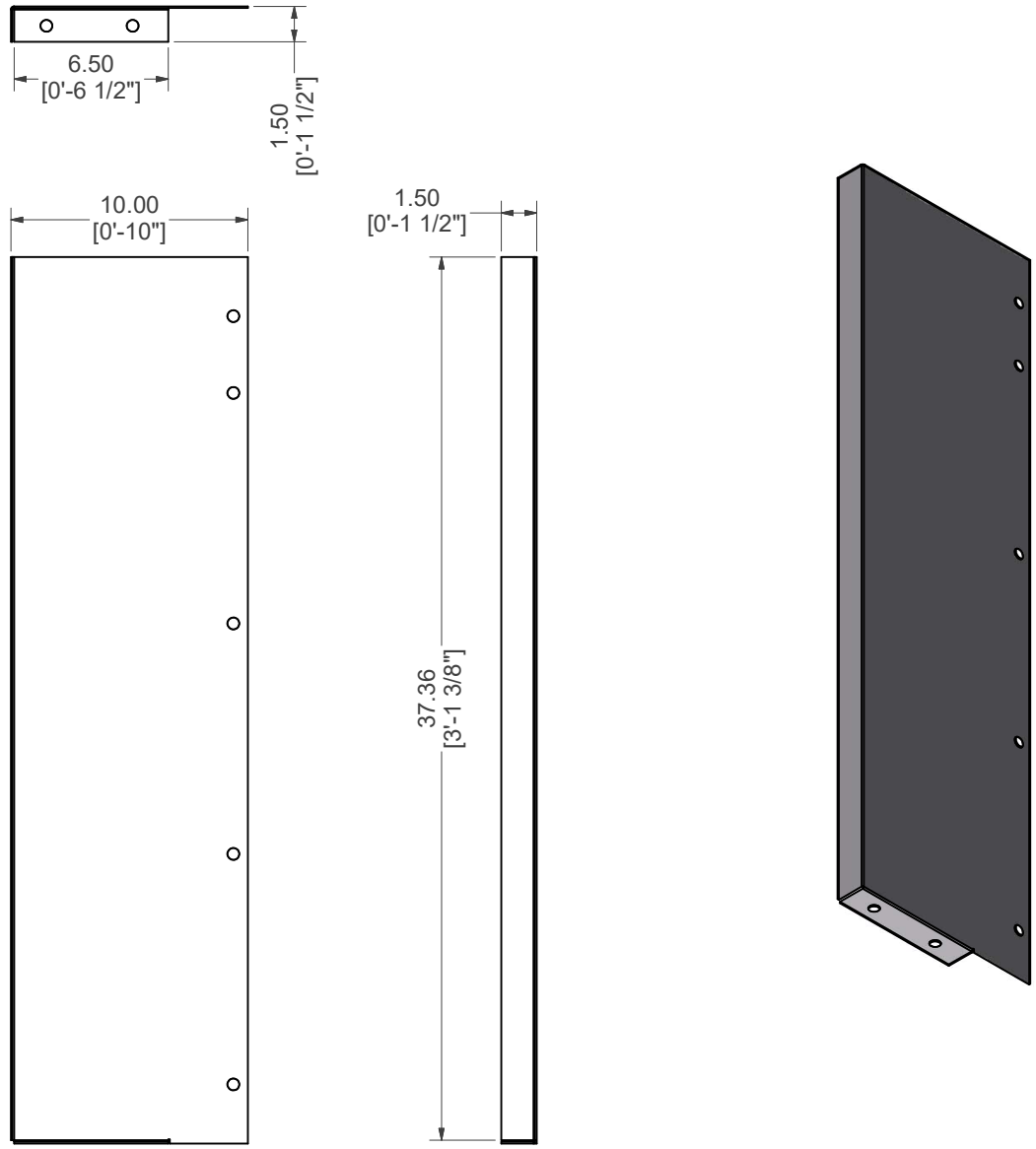

BRACE, TOP RISER SUPPORT

| | | | | |
|--|---|---------------------------------------|---|---------------|
| PART #: ESC-17632-TRS | WEIGHT: 8.82 lbmass | MACHINE TIME: N/A | FILE/DIRECTORY: C:\Vault\FTWDesign\CUSTOM STEPS\ESC-17000-17999\ESC-17632.idw | |
|  | TOLERANCES EXCEPT AS NOTED 0/0 0.0 0.00 0.000 0' ±1/8 ±0.25 ±0.0625 ±0.03125 ±1/2' | MATERIAL: 14 GA. GALVANIZED | DATE : 9/15/2023 | NOTES: |
| | | DRAWN BY: RK | SHEET : 23 OF 31 | |

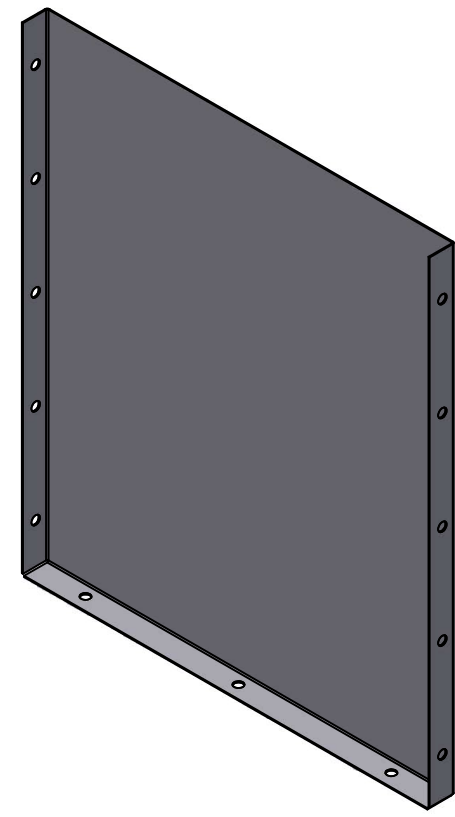
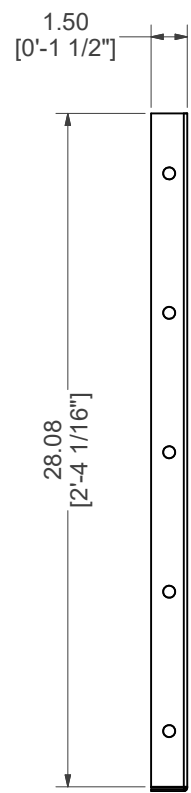
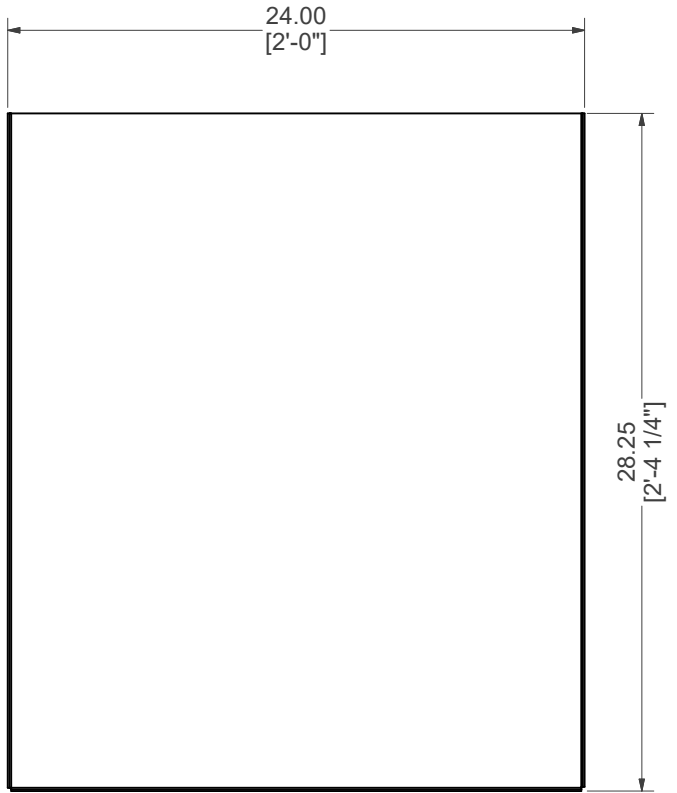
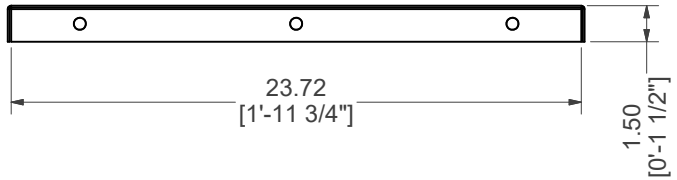

BRACE, SUNLEDGE BACK SUPPORT

| | | | |
|--|--|---------------------------------------|---|
| PART #: ESC-17632-SBS  | WEIGHT: 15.97 lbmass | MACHINE TIME: N/A | FILE/DIRECTORY: C:\Vault\FTWDesign\CUSTOM STEPS\ESC-17000-17999\ESC-17632.idw |
| | TOLERANCES EXCEPT AS NOTED 0/0 0.0 0.00 0.000 0' ±1/8 ±0.25 ±0.0625 ±0.03125 ±1/2' | MATERIAL: 14 GA. GALVANIZED | DATE : 9/15/2023 |
| DRAWN BY: RK | SHEET : 24 OF 31 | | |

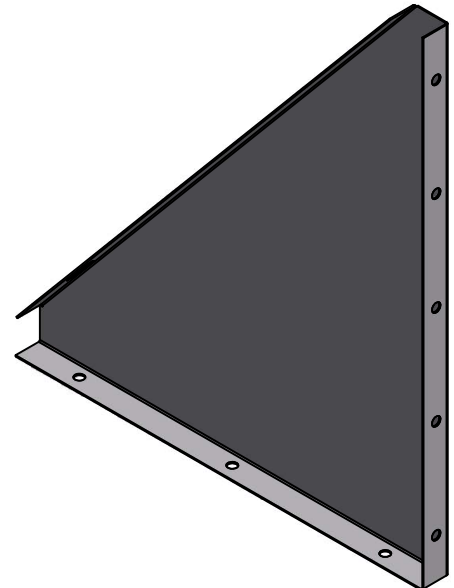
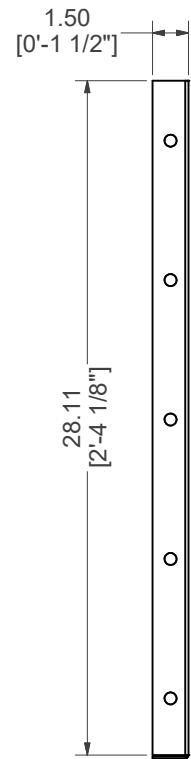
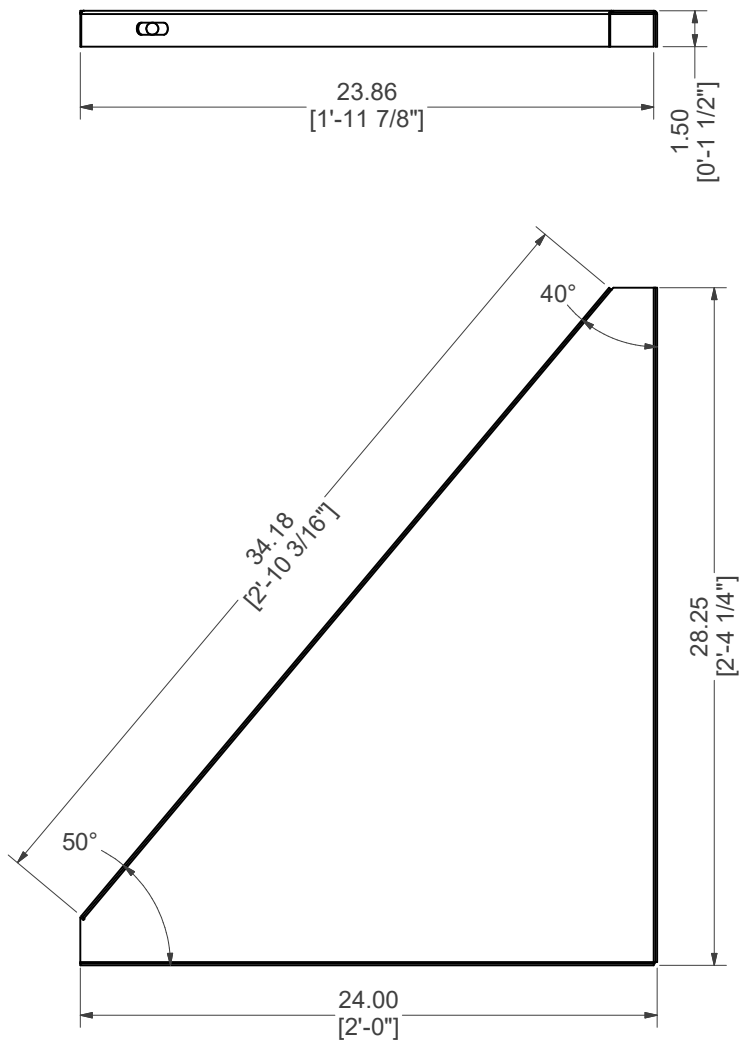

BRACE, SUNLEDGE RISER ANGLE SUPPORT

| | | | |
|---|--|---------------------------------------|---|
| PART #: ESC-9545-BUB  | WEIGHT: 10.28 lbmass | MACHINE TIME: N/A | FILE/DIRECTORY: C:\Vault\FTWDesign\CUSTOM STEPS\ESC-17000-17999\ESC-17632.idw |
| | TOLERANCES EXCEPT AS NOTED 0/0 0.0 0.00 0.000 0' ±1/8 ±0.25 ±0.0625 ±0.03125 ±1/2' | MATERIAL: 14 GA. GALVANIZED | DATE: 9/15/2023 |
| | DRAWN BY: RK | SHEET: 25 OF 31 | |

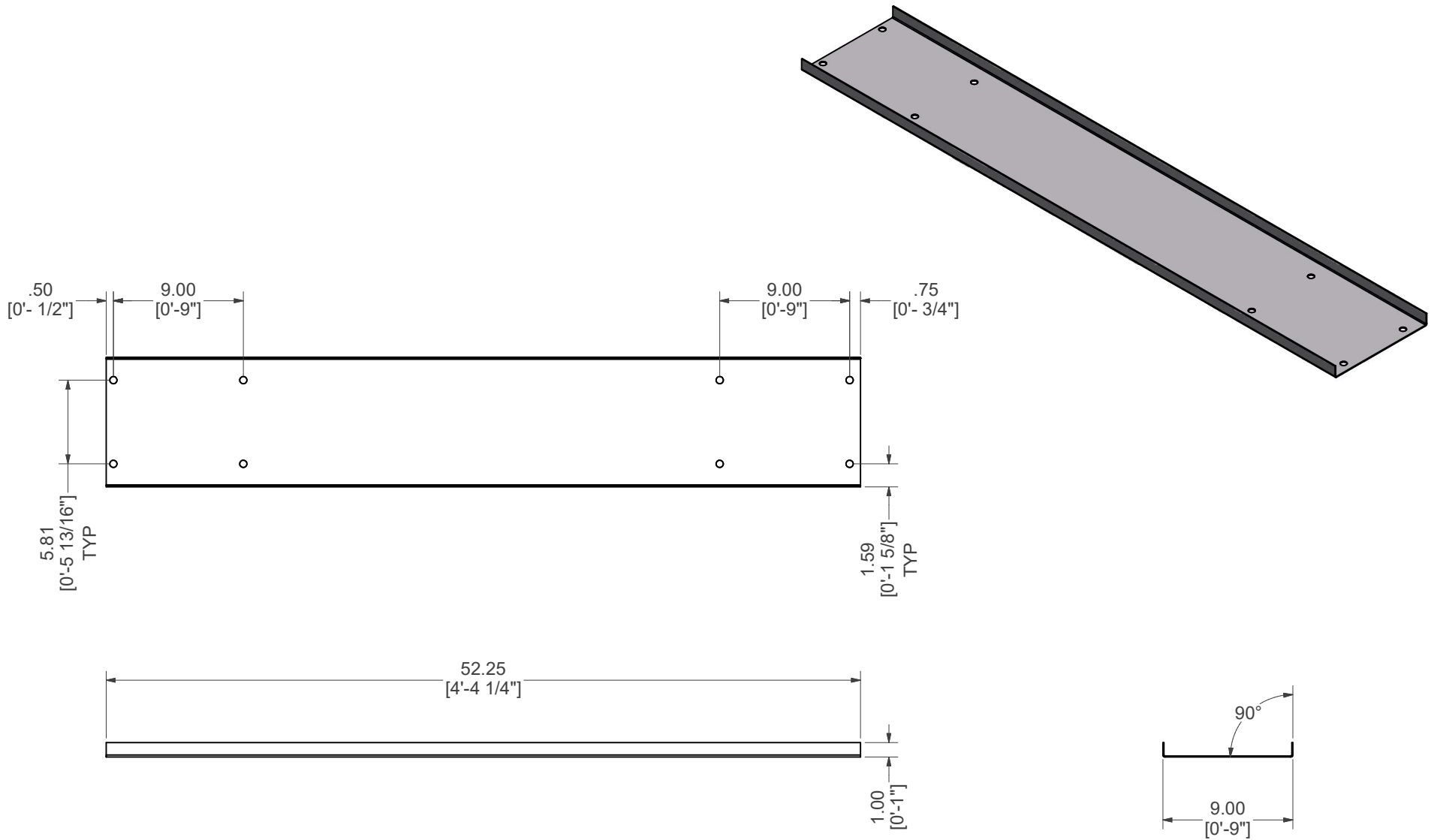

BRACE, CENTER SUPPORT

| | | | |
|--|--|---------------------------------------|---|
| PART #: ESC-9545-CB  | WEIGHT: 11.40 lbmass | MACHINE TIME: N/A | FILE/DIRECTORY: C:\Vault\FTWDesign\CUSTOM STEPS\ESC-17000-17999\ESC-17632.idw |
| | TOLERANCES EXCEPT AS NOTED 0/0 0.0 0.00 0.000 0' ±1/8 ±0.25 ±0.0625 ±0.03125 ±1/2' | MATERIAL: 14 GA. GALVANIZED | DATE: 9/15/2023 |
| DRAWN BY: RK | SHEET: 26 OF 31 | | |

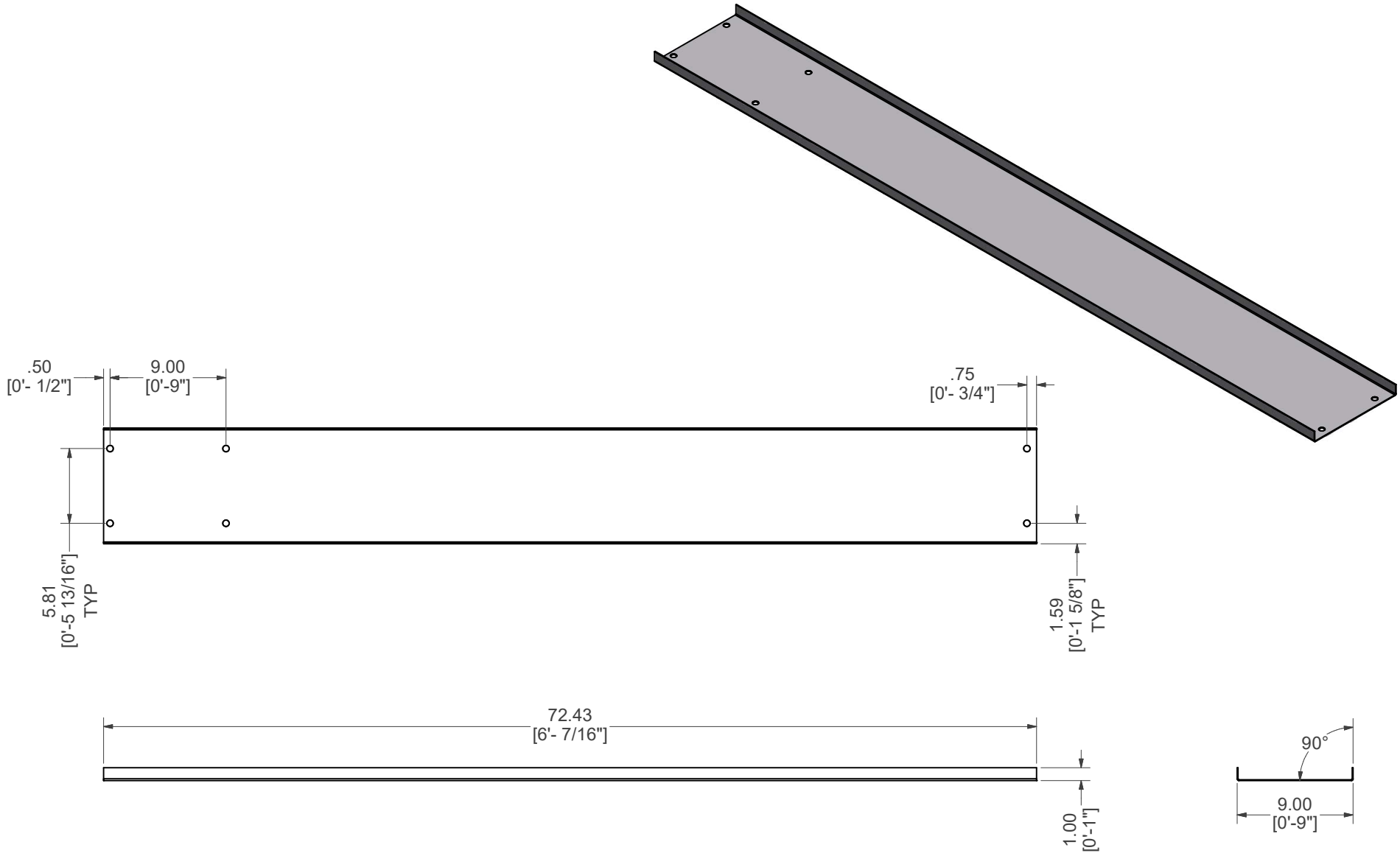

BRACE, CENTER SUPPORT

| | | | |
|---|--|---------------------------------------|---|
| PART #: ESC-9545-CB1  | WEIGHT: 15.83 lbmass | MACHINE TIME: N/A | FILE/DIRECTORY: C:\Vault\FTWDesign\CUSTOM STEPS\ESC-17000-17999\ESC-17632.idw |
| | TOLERANCES EXCEPT AS NOTED 0/0 0.0 0.00 0.000 0' ±1/8 ±0.25 ±0.0625 ±0.03125 ±1/2' | MATERIAL: 14 GA. GALVANIZED | DATE: 9/15/2023 |
| DRAWN BY: RK | SHEET: 27 OF 31 | | |

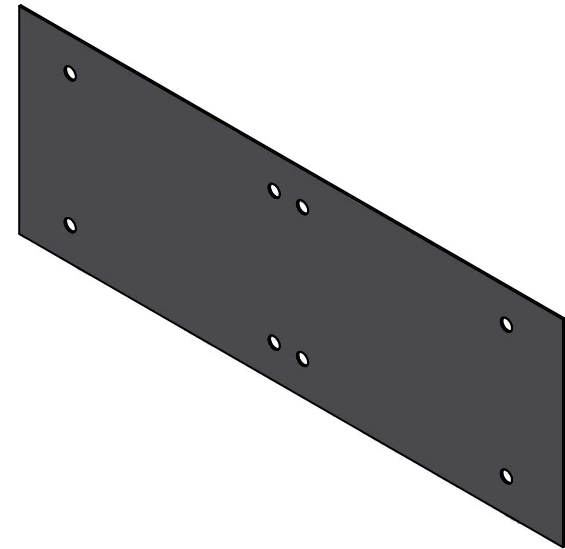
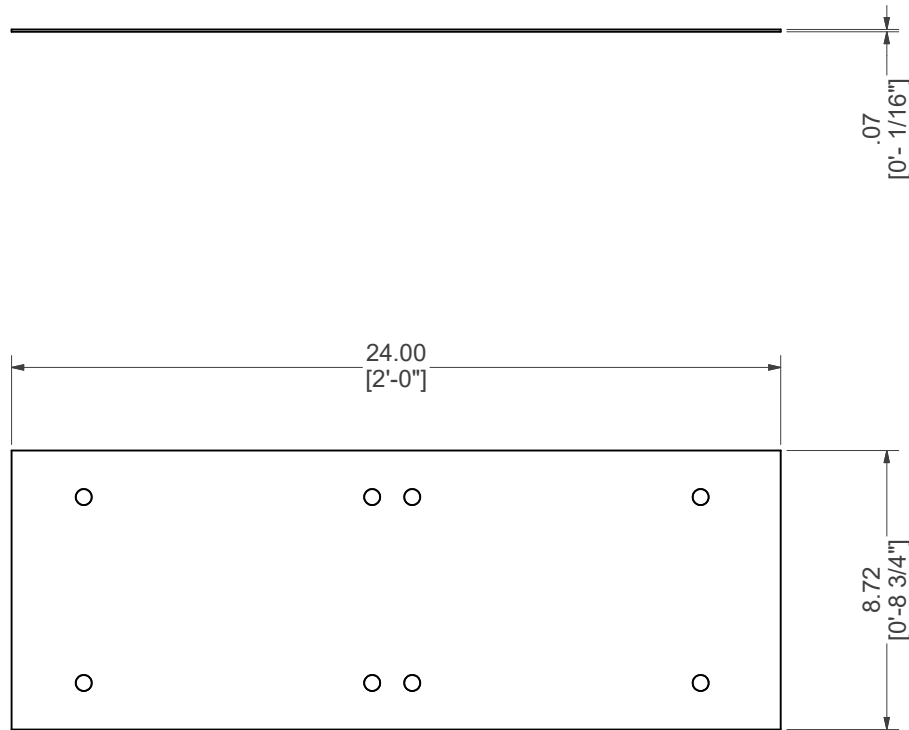

BRACE, FLAT PLATE

| | | | | |
|--|---|---------------------------------------|---|--|
| PART #: ESC-9545-PT | WEIGHT: 4.22 lbmass | MACHINE TIME: N/A | FILE/DIRECTORY: C:\Vault\FTWDesign\CUSTOM STEPS\ESC-17000-17999\ESC-17632.idw | |
|  | TOLERANCES EXCEPT AS NOTED 0/0 0.0 0.00 0.000 0' ±1/8 ±0.25 ±0.0625 ±0.03125 ±1/2' | MATERIAL: 14 GA. GALVANIZED | | DATE : 9/15/2023 NOTES: |
| | | DRAWN BY: RK | | SHEET : 28 OF 31 |

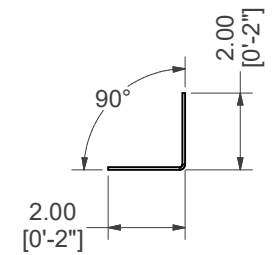
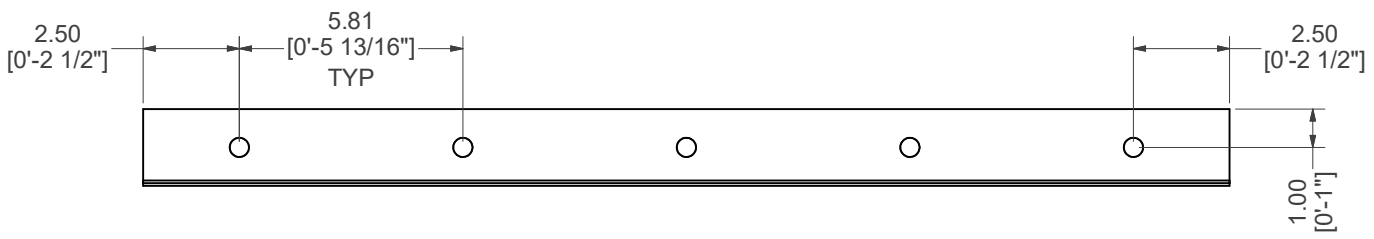
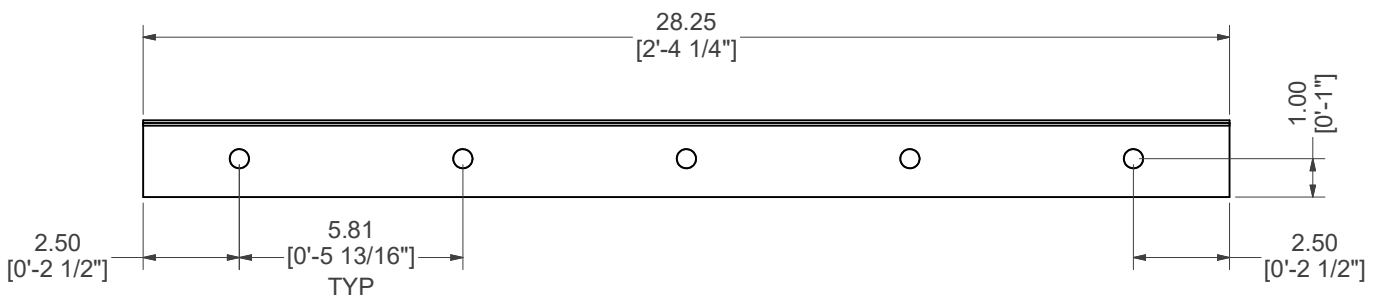
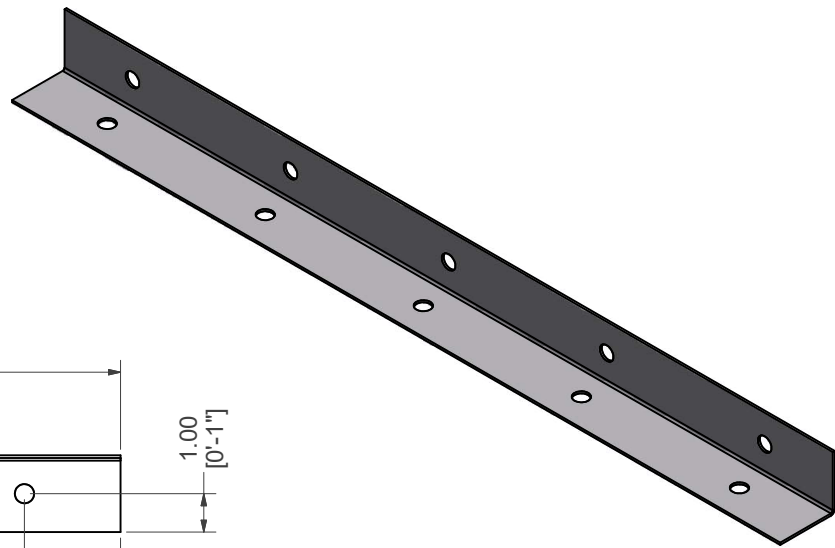

BRACE, 90° L BRACKET

| | | | |
|--|--|---------------------------------------|---|
| PART #: ESC-9545-BB  | WEIGHT: 2.19 lbmass | MACHINE TIME: N/A | FILE/DIRECTORY: C:\Vault\FTWDesign\CUSTOM STEPS\ESC-17000-17999\ESC-17632.idw |
| | TOLERANCES EXCEPT AS NOTED 0/0 0.0 0.00 0.000 0' ±1/8 ±0.25 ±0.0625 ±0.03125 ±1/2' | MATERIAL: 14 GA. GALVANIZED | DATE : 9/15/2023 |
| DRAWN BY: RK | SHEET : 29 OF 31 | | |

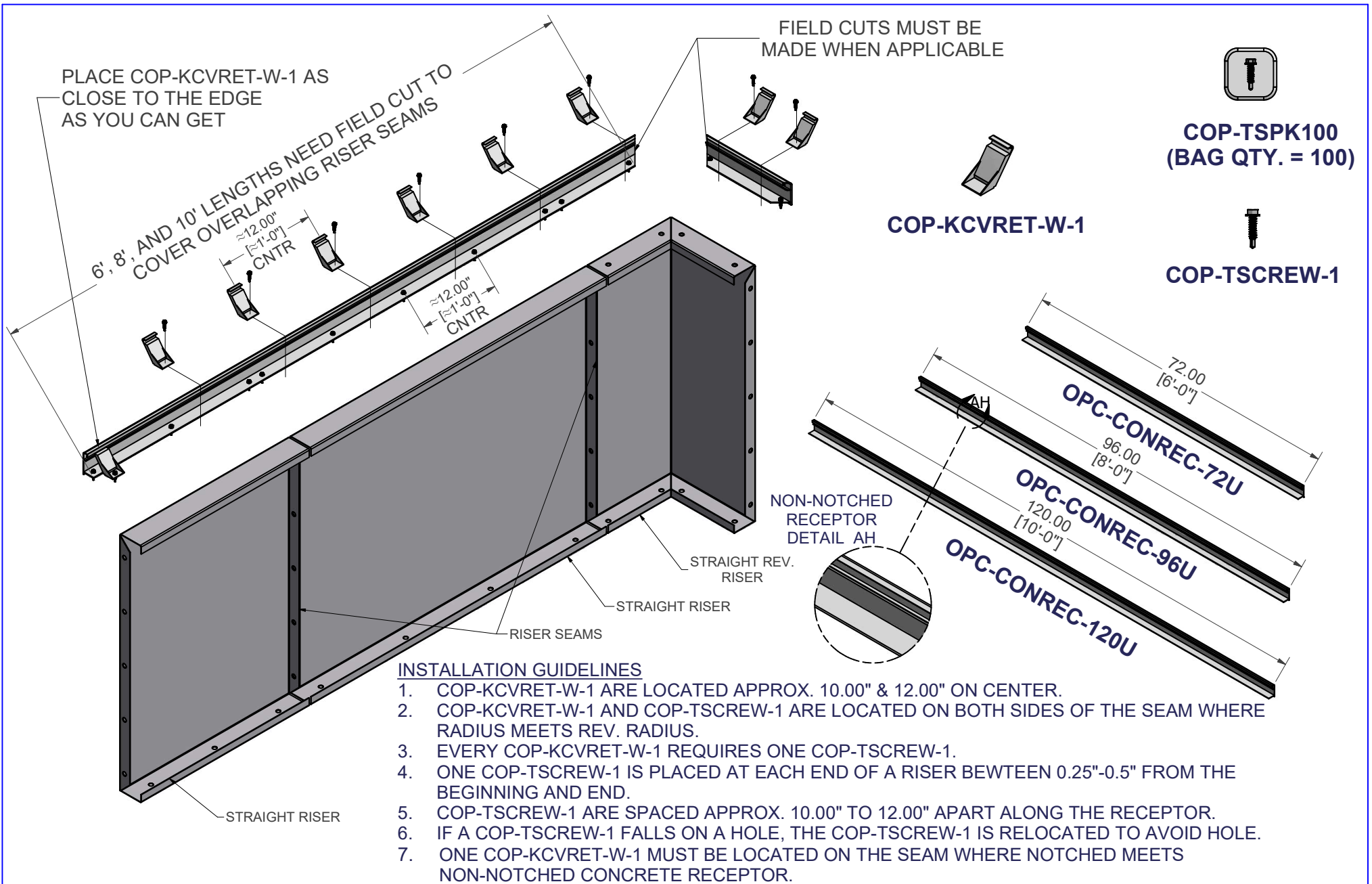

INSTALLATION GUIDELINES

1. COP-KCVRET-W-1 ARE LOCATED APPROX. 10.00" & 12.00" ON CENTER.
2. COP-KCVRET-W-1 AND COP-TSCREW-1 ARE LOCATED ON BOTH SIDES OF THE SEAM WHERE RADIUS MEETS REV. RADIUS.
3. EVERY COP-KCVRET-W-1 REQUIRES ONE COP-TSCREW-1.
4. ONE COP-TSCREW-1 IS PLACED AT EACH END OF A RISER BETWEEN 0.25"-0.5" FROM THE BEGINNING AND END.
5. COP-TSCREW-1 ARE SPACED APPROX. 10.00" TO 12.00" APART ALONG THE RECEPTOR.
6. IF A COP-TSCREW-1 FALLS ON A HOLE, THE COP-TSCREW-1 IS RELOCATED TO AVOID HOLE.
7. ONE COP-KCVRET-W-1 MUST BE LOCATED ON THE SEAM WHERE NOTCHED MEETS NON-NOTCHED CONCRETE RECEPTOR.

NON-NOTCHED CONCRETE RECEPTOR FIELD INSTALLATION

| | | | |
|--|---|-----------------------------|---|
| PART # STRAIGHT CONCRETE RECEPTOR | WEIGHT: 77.51 lbmass | MACHINE TIME: N/A | FILE/DIRECTORY: C:\Vault\FTWDesign\CUSTOM STEPS\ESC-17000-17999\ESC-17632.idw |
| | TOLERANCES EXCEPT AS NOTED 0/0 0.0 0.00 0.000 0' ±1/8 ±0.25 ±0.0625 ±0.03125 ±1/2" | MATERIAL: | DATE: 9/15/2023 |
| | DRAWN BY: RK | SHEET: 30 OF 31 | |

PLACE COP-KCVRET-W-1 AT SEAMS WHERE STRAIGHT MEETS A RADIUS/REV. RADIUS.

PLACE COP-TSCREW-1 ON BOTH SIDES OF THE SEAMS.

PLACE COP-KCVRET-W-1 AS CLOSE TO THE END EDGE AS YOU CAN GET.

FIELD CUTS MUST BE MADE WHEN APPLICABLE



COP-TSPK100
(BAG QTY. = 100)



COP-TSCREW-1

COP-KCVRET-W-1

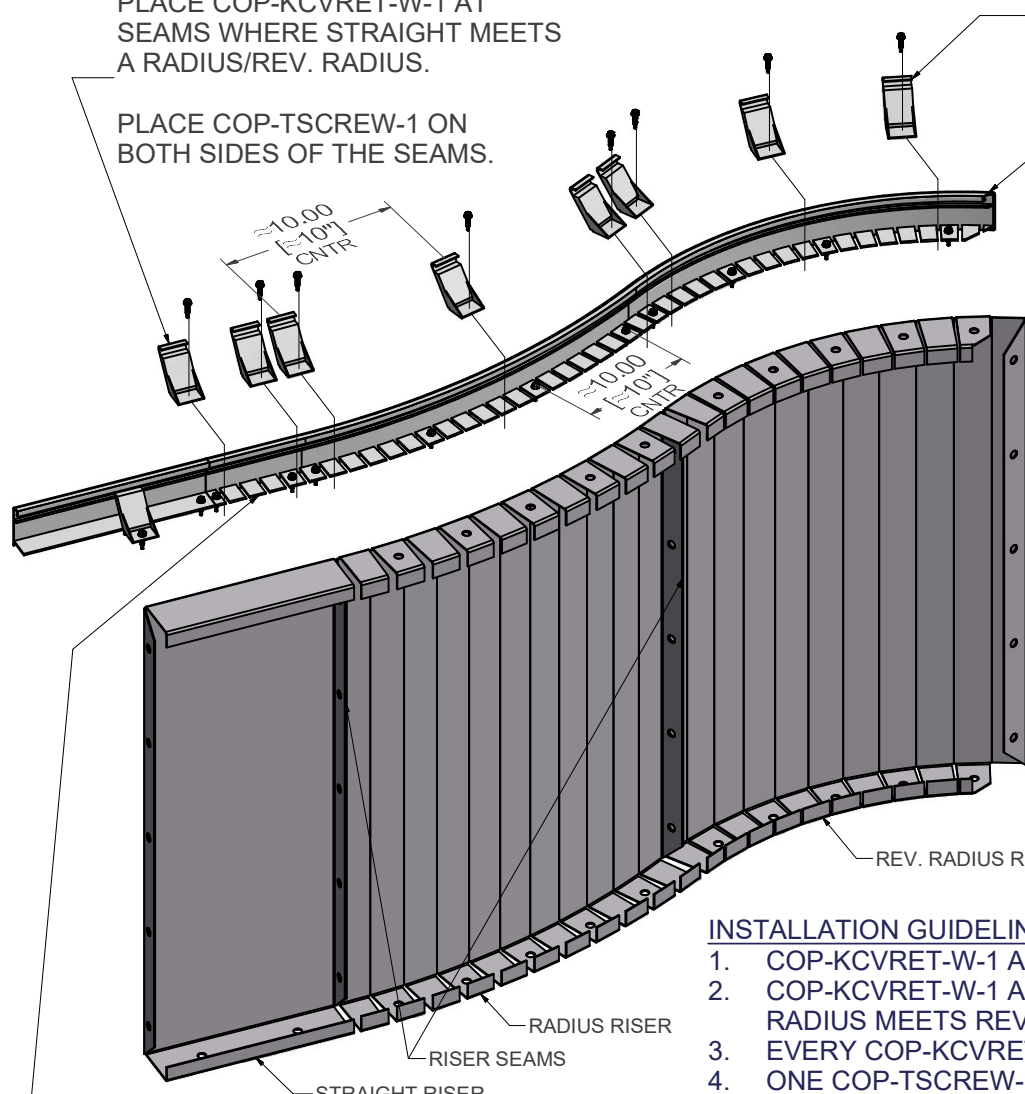

NOTCHED RECEPTOR DETAIL AJ

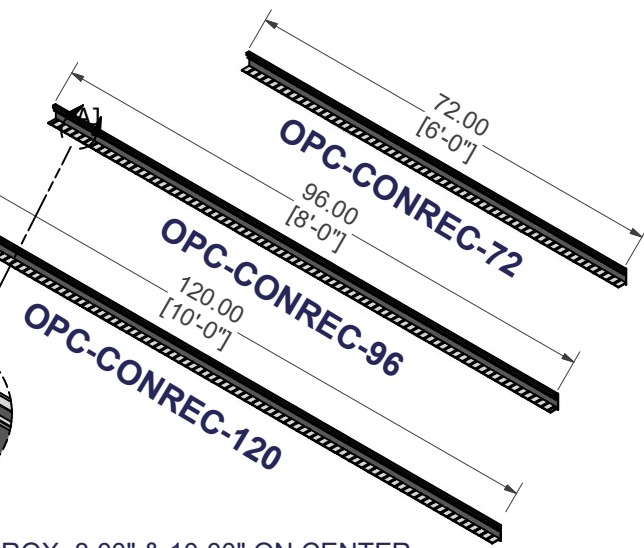
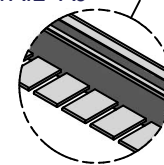

ALLOW AN APPROX. OF 6.00" OF OVERLAP GOING FROM RADIUS/ REV. RADIUS TO A STRAIGHT RISER.

INSTALLATION GUIDELINES

1. COP-KCVRET-W-1 ARE LOCATED APPROX. 8.00" & 10.00" ON CENTER.
2. COP-KCVRET-W-1 AND COP-TSCREW-1 ARE LOCATED ON BOTH SIDES OF THE SEAM WHERE RADIUS MEETS REV. RADIUS.
3. EVERY COP-KCVRET-W-1 REQUIRES ONE COP-TSCREW-1.
4. ONE COP-TSCREW-1 IS PLACED AT EACH END OF A RISER BETWEEN 0.25"-0.5" FROM THE BEGINNING AND END.
5. COP-TSCREW-1 ARE SPACED APPROX. 8.00" TO 10.00" APART ALONG THE RECEPTOR.
6. IF A COP-TSCREW-1 FALLS ON A HOLE, THE COP-TSCREW-1 IS RELOCATED TO AVOID HOLE.
7. ONE COP-KCVRET-W-1 MUST BE LOCATED ON THE SEAM WHERE NOTCHED MEETS NON-NOTCHED CONCRETE RECEPTOR.

NOTCHED CONCRETE RECEPTOR FIELD INSTALLATION

REV-RADIUS CONCRETE RECEPTOR

WEIGHT:
52.49 lbmass

MACHINE TIME:
N/A

FILE/DIRECTORY:

C:\Vault\FTWDesign\CUSTOM STEPS\ESC-17000-17999\ESC-17632.idw



TOLERANCES EXCEPT AS NOTED
0/0 0.0 0.00 0.000 0'
±1/8 ±0.25 ±0.0625 ±0.03125 ±1/2'

MATERIAL:

DATE: 9/15/2023

NOTES:

DRAWN BY: RK

SHEET: 31 OF 31