

Parts List				
ITEM	QTY	PART NUMBER	DESCRIPTION	
1	5	48-Z-RIB	48" Z-RIB	
2	79	COP-KCVRET-W-1	COP COPING STIFFNER 1 5/8"-1PC	
3	2	ESC-8029-TMRS	BRACE, TOP MIDDLE RISER SUPPORT	
4	6	ESC-9545-BUB	BRACE, SUNLEDGE RISER ANGLE SUPPORT	
5	2	ESC-9625-BB	BRACE, 90° L BRACKET	
6	2	ESC-9625-CB	BRACE, CENTER SUPPORT	
7	1	ESC-9625-CWR	REV. RAD, CORNER WALL, RIGHT	
8	2	ESC-9625-PT	BRACE, FLAT PLATE	
9	2	ESC-9625-SRM	REV RAD, SUNLEDGE RISER, MIDDLE	
10	1	ESC-9625-SRR	RADIUS, SUNLEDGE RISER, RIGHT	
11	1	ESC-9625-SRRE	RADIUS, SUNLEDGE RISER, RIGHT, END	
12	1	ESC-18336-B	BRACE, 3-RISER SUPPORT	
13	1	ESC-18336-BRL	STRAIGHT, BOTTOM RISER, LEFT	
14	1	ESC-18336-BRR	STRAIGHT, BOTTOM RISER, RIGHT	
15	1	ESC-18336-BWL	STRAIGHT, BACK WALL, LEFT	
16	1	ESC-18336-BWM	STRAIGHT, BACK WALL, MIDDLE	
17	2	ESC-18336-BWR	STRAIGHT, BACK WALL, RIGHT	
18	2	ESC-18336-CSB	BRACE, 3-RISER SUPPORT	
19	1	ESC-18336-CWL	RADIUS, CORNER WALL, LEFT	
20	4	ESC-18336-MR	STRAIGHT, MIDDLE RISER	
21	1	ESC-18336-SRB	STRAIGHT, SUNLEDGE RISER, BACK	
22	1	ESC-18336-SRL	REV RAD, SUNLEDGE RISER, LEFT	
23	5	ESC-18336-SRS	BRACE, SUNLEDGE RISER SUPPORT	
24	1	ESC-18336-SRTR	STR REV, TOP RISER	
25	1	ESC-18336-SWL	STRAIGHT, SIDE WALL, LEFT	
26	1	ESC-18336-SWR	STRAIGHT, SIDE WALL, RIGHT	
27	2	ESC-18336-TRB	BRACE, TOP RISER SUPPORT	
28	1	ESC-18336-TRL	STRAIGHT, TOP RISER, LEFT	
29	1	ESC-18336-TRM	STRAIGHT, TOP RISER, MIDDLE	
30	2	ESC-18336-TRMS	BRACE, TOP RISER MIDDLE SUPPORT	
31	1	ESC-18336-TRR	STRAIGHT, TOP RISER, RIGHT	
32	1	ESC-18336-TRS	BRACE, TOP RISER SUPPORT	
33	18'	OPC-CONREC-XX	NOTCHED CONCRETE RECEPTOR	
34	45'	OPC-CONREC-XXU	UN-NOTCHED CONCRETE RECEPTOR	
35	65'	SSC-1099-PFT	STEEL STEP PVC BEAD RETAINER (PER FT)	

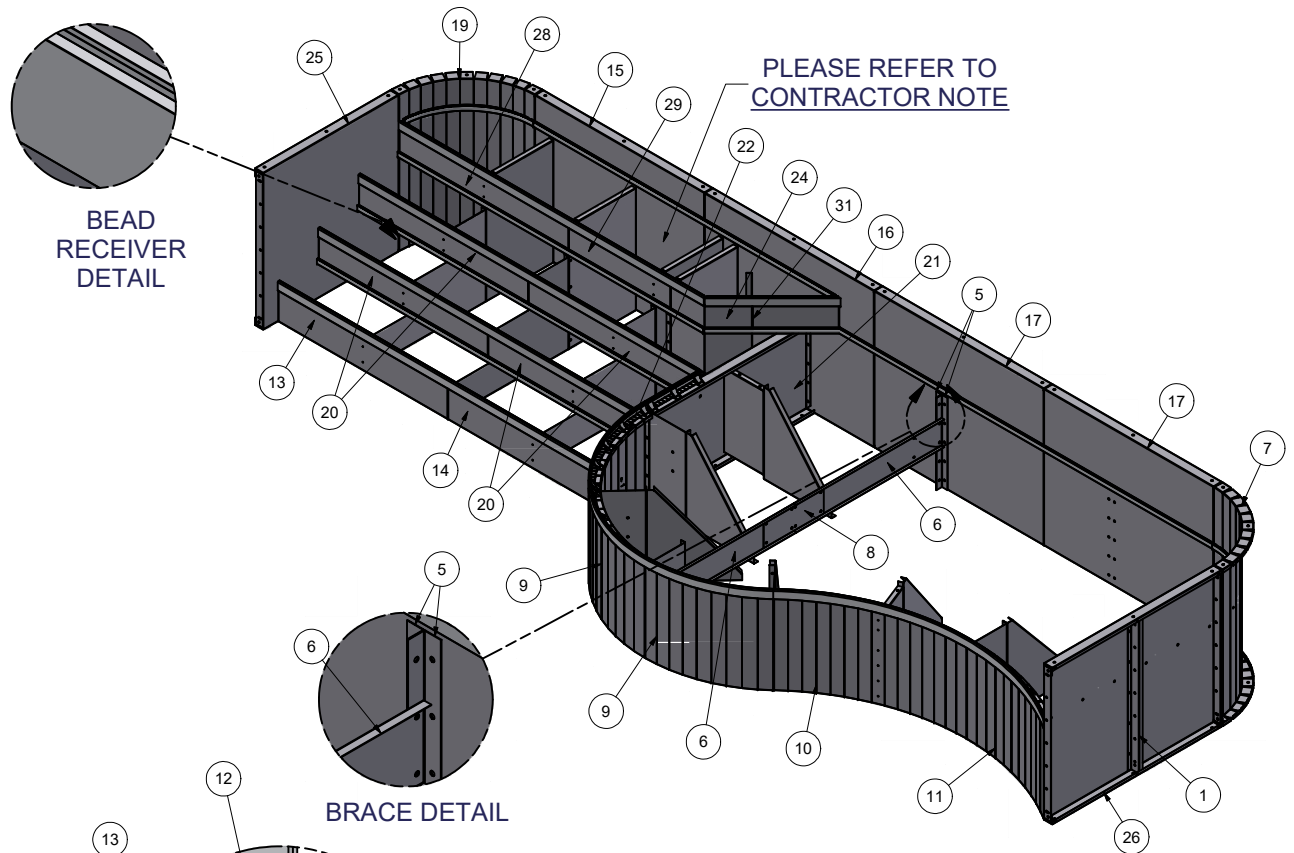

**CONTRACTOR NOTE:**

BACK FILL STEP/SUNLEDGE AREA WITH COMPACTED EARTH MATERIAL. FINISH STEP/SUNLEDGE AREA WITH 2" OF HARDEN FLOOR MATERIAL TO MATCH REQUIRED DEPTH (FLUSH WITH TOP OF BEAD RECEIVER).

**CONTRACTOR NOTE:**

CONTRACTOR IS RESPONSIBLE FOR SECURING ALL RISERS INTO PLACE WITH REBAR HOLES BEFORE BACKFILLING THIS CUSTOM STEP

KEEP BEAD RECEIVER ATTACHED TO THE RISERS AND WALL PANELS FOR SHIPPING. A TOTAL OF 780" (65') OF BEAD RECEIVER IS REQUIRED.

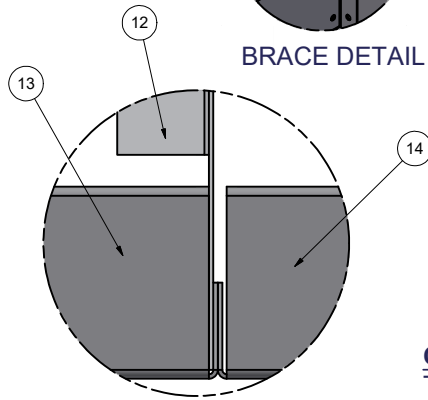

**TOP VIEW**  
BRACE CONNECTED TO INSIDE FLANGE OF LEFT RISER

**CONTRACTOR MUST FIELD FIT ALL CONCRETE RECEPTOR.**  
TOTALS REQUIRED FOR THIS CUSTOM PRODUCT APPLICATION.  
OPC-CONREC-XX (NOTCHED) = 216" (18')  
OPC-CONREC-XXU (UN-NOTCHED) = 540" (45')  
COP-KCVRET-W-1 (STIFFENER) = 79

# 24' X 7' X 2'R CRN OT STEP W/ WAVE TREAD SUNLEDGE RIGHT

<b>PART #:</b> ESC-18336	<b>WEIGHT:</b> 1253.00 lbmass	<b>MACHINE TIME:</b> N/A	<b>FILE/DIRECTORY:</b> C:\Vault\FTW\Design\CUSTOM STEPS\ESC-18000-18999\ESC-18336.idw
	TOLERANCES EXCEPT AS NOTED 0/0 0.0 0.00 0.000 0' ±1/8 ±0.25 ±0.0625 ±0.03125 ±1/2"	<b>MATERIAL:</b>	<b>DATE:</b> 3/14/2024
		<b>DRAWN BY:</b> SA	<b>SHEET:</b> 1 OF 35
		<b>NOTES:</b>	

Parts List

ITEM	QTY	PART NUMBER	DESCRIPTION
1	5	48-Z-RIB	48" Z-RIB
2	79	COP-KCVRET-W-1	COP COPING STIFFNER 1 5/8"-1PC
3	2	ESC-8029-TMRS	BRACE, TOP MIDDLE RISER SUPPORT
4	6	ESC-9545-BUB	BRACE, SUNLEDGE RISER ANGLE SUPPORT
5	2	ESC-9625-BB	BRACE, 90° L BRACKET
6	2	ESC-9625-CB	BRACE, CENTER SUPPORT
7	1	ESC-9625-CWR	REV. RAD, CORNER WALL, RIGHT
8	2	ESC-9625-PT	BRACE, FLAT PLATE
9	2	ESC-9625-SRM	REV RAD, SUNLEDGE RISER, MIDDLE
10	1	ESC-9625-SRR	RADIUS, SUNLEDGE RISER, RIGHT
11	1	ESC-9625-SRRE	RADIUS, SUNLEDGE RISER, RIGHT, END
12	1	ESC-18336-B	BRACE, 3-RISER SUPPORT
13	1	ESC-18336-BRL	STRAIGHT, BOTTOM RISER, LEFT
14	1	ESC-18336-BRR	STRAIGHT, BOTTOM RISER, RIGHT
15	1	ESC-18336-BWL	STRAIGHT, BACK WALL, LEFT
16	1	ESC-18336-BWM	STRAIGHT, BACK WALL, MIDDLE
17	2	ESC-18336-BWR	STRAIGHT, BACK WALL, RIGHT
18	2	ESC-18336-CSB	BRACE, 3-RISER SUPPORT
19	1	ESC-18336-CWL	RADIUS, CORNER WALL, LEFT
20	4	ESC-18336-MR	STRAIGHT, MIDDLE RISER
21	1	ESC-18336-SRB	STRAIGHT, SUNLEDGE RISER, BACK
22	1	ESC-18336-SRL	REV RAD, SUNLEDGE RISER, LEFT
23	5	ESC-18336-SRS	BRACE, SUNLEDGE RISER SUPPORT
24	1	ESC-18336-SRTR	STR REV, TOP RISER
25	1	ESC-18336-SWL	STRAIGHT, SIDE WALL, LEFT
26	1	ESC-18336-SWR	STRAIGHT, SIDE WALL, RIGHT
27	2	ESC-18336-TRB	BRACE, TOP RISER SUPPORT
28	1	ESC-18336-TRL	STRAIGHT, TOP RISER, LEFT
29	1	ESC-18336-TRM	STRAIGHT, TOP RISER, MIDDLE
30	2	ESC-18336-TRMS	BRACE, TOP RISER MIDDLE SUPPORT
31	1	ESC-18336-TRR	STRAIGHT, TOP RISER, RIGHT
32	1	ESC-18336-TRS	BRACE, TOP RISER SUPPORT
33	18'	OPC-CONREC-XX	NOTCHED CONCRETE RECEPTOR
34	45'	OPC-CONREC-XXU	UN-NOTCHED CONCRETE RECEPTOR
35	65'	SSC-1099-PFT	STEEL STEP PVC BEAD RETAINER (PER FT)

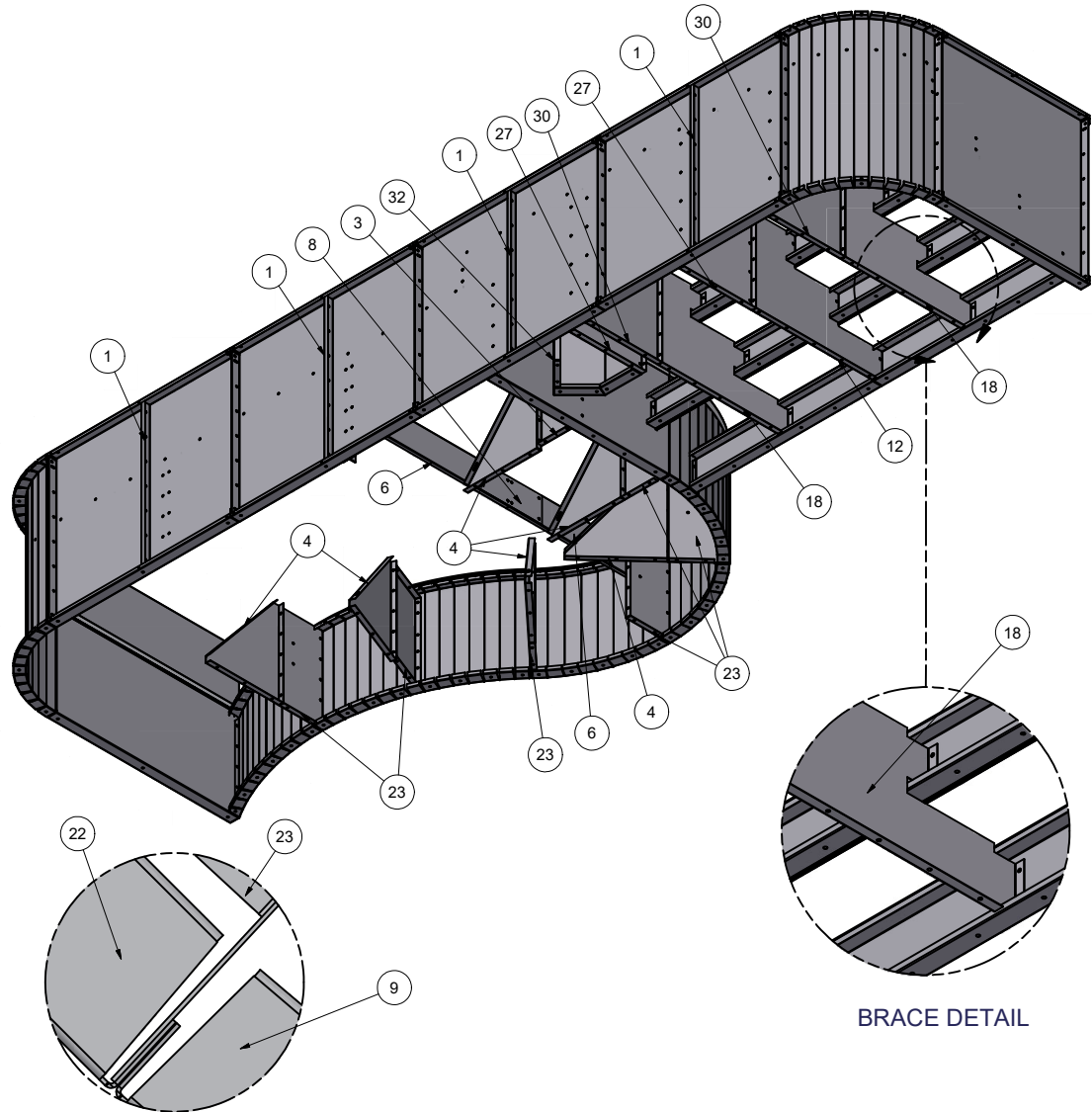

**TOP VIEW**  
BRACE CONNECTED TO  
INSIDE FLANGE OF LEFT RISER

**BRACE DETAIL**

# 24' X 7' X 2'R CRN OT STEP W/ WAVE TREAD SUNLEDGE RIGHT

<b>PART #:</b> ESC-18336 	<b>WEIGHT:</b> 1253.00 lbmass	<b>MACHINE TIME:</b> N/A	<b>FILE/DIRECTORY:</b> C:\Vault\FTW\Design\CUSTOM STEPS\ESC-18000-18999\ESC-18336.idw
	TOLERANCES EXCEPT AS NOTED 0/0 0.0 0.00 0.000 0' ±1/8 ±0.25 ±0.0625 ±0.03125 ±1/2"	<b>MATERIAL:</b>	<b>DATE:</b> 3/14/2024
		<b>DRAWN BY:</b> SA	<b>SHEET:</b> 2 OF 35

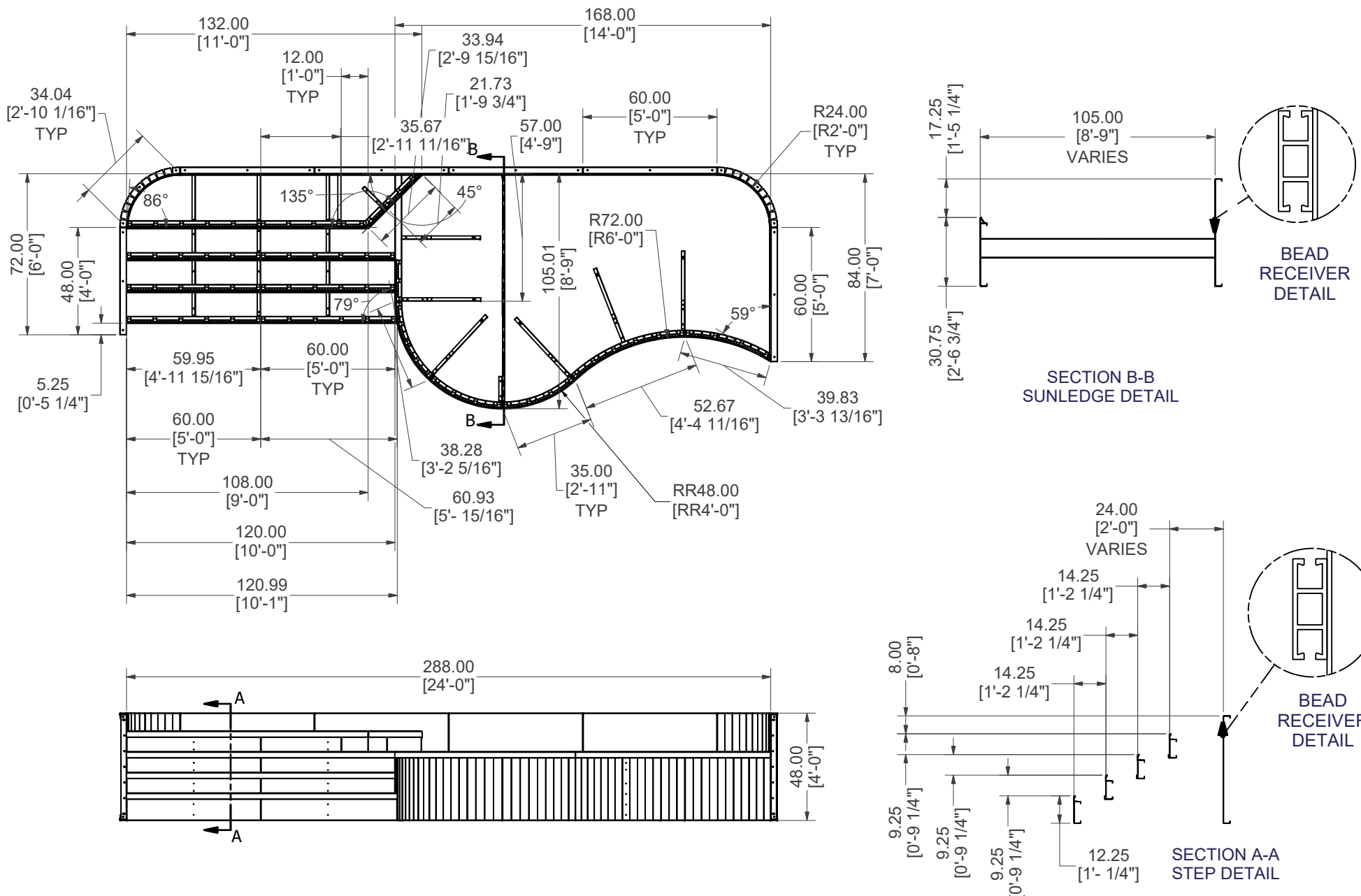

# 24' X 7' X 2'R CRN OT STEP W/ WAVE TREAD SUNLEDGE RIGHT

<b>PART #:</b> ESC-18336	<b>WEIGHT:</b> 1253.00 lbmass	<b>MACHINE TIME:</b> N/A	<b>FILE/DIRECTORY:</b> C:\Vault\FTW\Design\CUSTOM STEPS\ESC-18000-18999\ESC-18336.idw
	TOLERANCES EXCEPT AS NOTED	<b>MATERIAL:</b>	<b>DATE:</b> 3/14/2024
	0/0 0.0 0.00 0.000 0' ±1/8 ±0.25 ±0.0625 ±0.03125 ±1/2"	<b>DRAWN BY:</b> SA	<b>SHEET:</b> 3 OF 35

Parts List			
ITEM	QTY	PART NUMBER	DESCRIPTION
1	1	48-Z-RIB	48" Z-RIB
2	1	ESC-18336-BWL	STRAIGHT, BACK WALL, LEFT

# WELDCODE #17

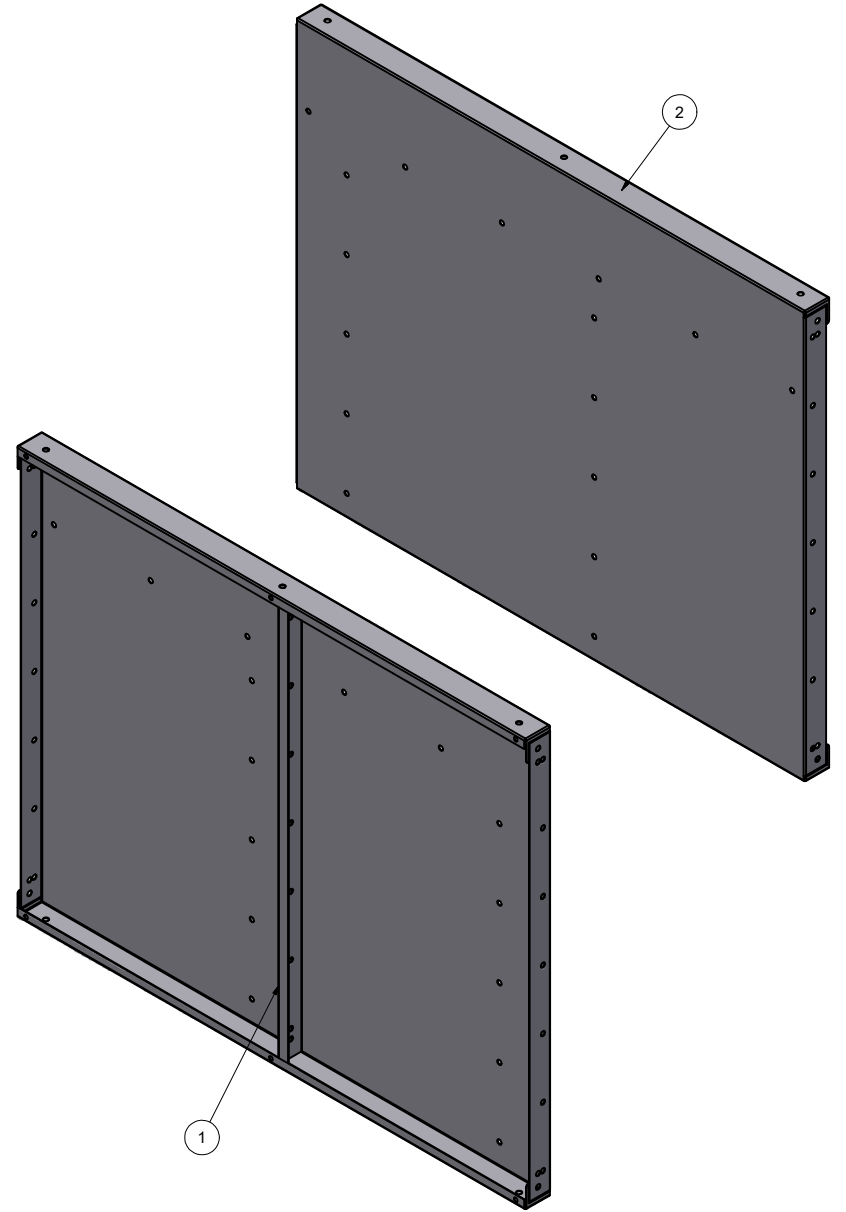
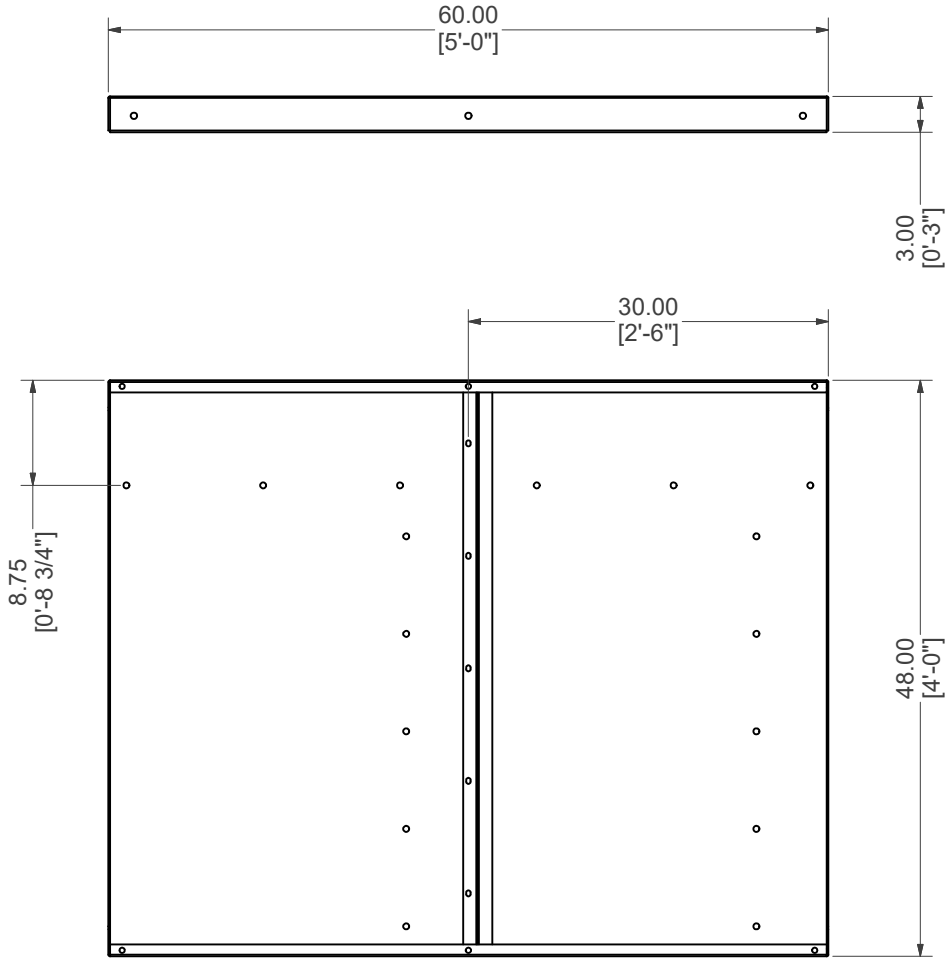

## STRAIGHT, BACK WALL, LEFT W/ Z-RIBS

<b>PART #:</b> ESC-18336-BWL 	<b>WEIGHT:</b> 77.06 lbmass	<b>MACHINE TIME:</b> N/A	<b>FILE/DIRECTORY:</b> C:\Vault\FTW\Design\CUSTOM STEPS\ESC-18000-18999\ESC-18336.idw
	<b>TOLERANCES EXCEPT AS NOTED</b> 0/0 0.0 0.00 0.000 0' ±1/8 ±0.25 ±0.0625 ±0.03125 ±1/2'	<b>MATERIAL:</b>  <b>DRAWN BY:</b> SA	<b>DATE:</b> 3/14/2024  <b>SHEET:</b> 4 OF 35

Parts List			
ITEM	QTY	PART NUMBER	DESCRIPTION
1	1	48-Z-RIB	48" Z-RIB
2	1	ESC-18336-BWM	STRAIGHT, BACK WALL, MIDDLE

# WELDCODE #17

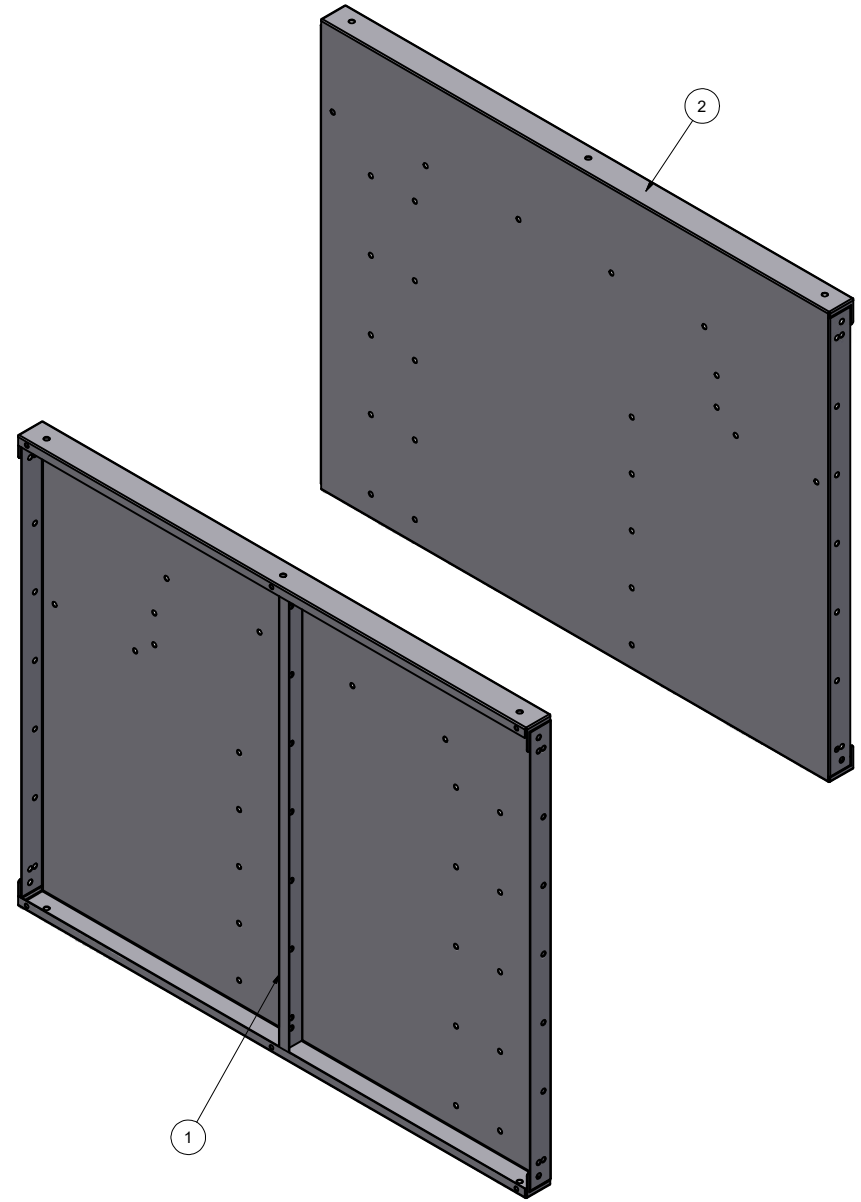
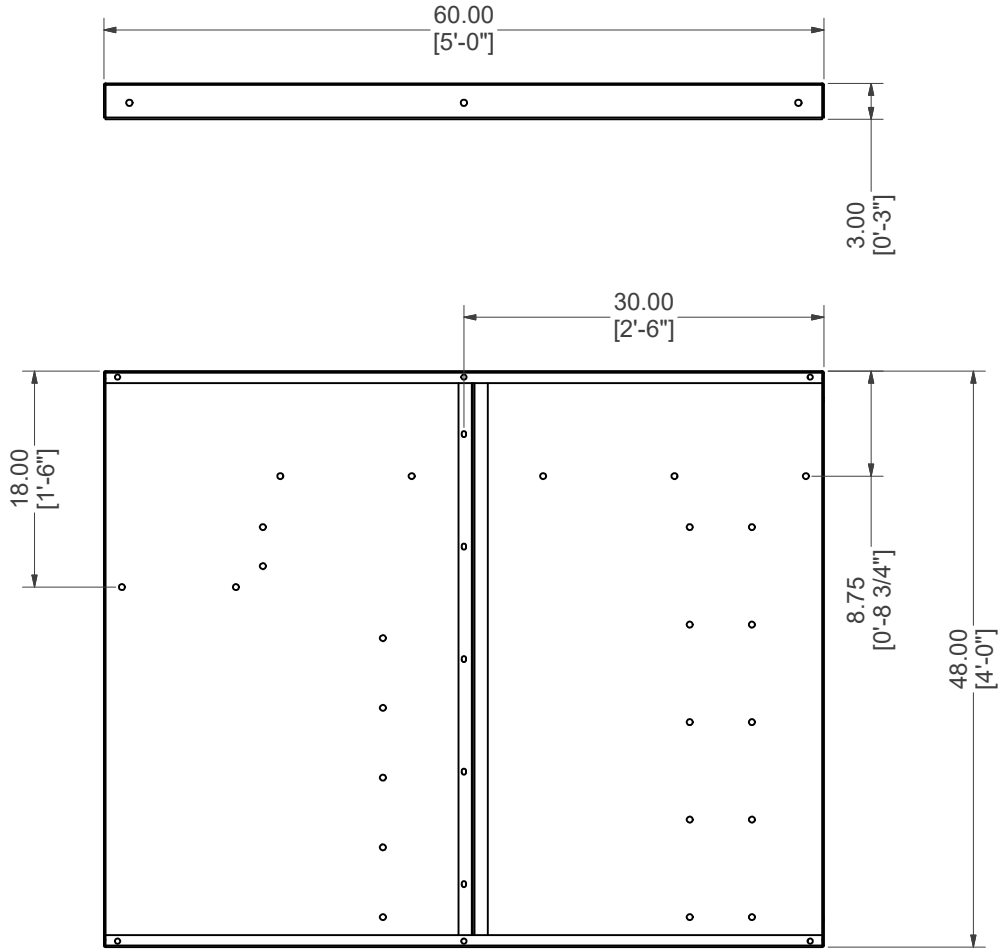

## STRAIGHT, BACK WALL, MIDDLE W/ Z-RIBS

<b>PART #:</b> ESC-18336-BWM 	<b>WEIGHT:</b> 77.03 lbmass	<b>MACHINE TIME:</b> N/A	<b>FILE/DIRECTORY:</b> C:\Vault\FTW\Design\CUSTOM STEPS\ESC-18000-18999\ESC-18336.idw
	TOLERANCES EXCEPT AS NOTED 0/0 0.0 0.00 0.000 0' ±1/8 ±0.25 ±0.0625 ±0.03125 ±1/2'	<b>MATERIAL:</b>  <b>DRAWN BY:</b> SA	<b>DATE:</b> 3/14/2024  <b>SHEET:</b> 5 OF 35

Parts List			
ITEM	QTY	PART NUMBER	DESCRIPTION
1	1	48-Z-RIB	48" Z-RIB
2	1	ESC-18336-BWR	STRAIGHT, BACK WALL, RIGHT

# WELDCODE #17

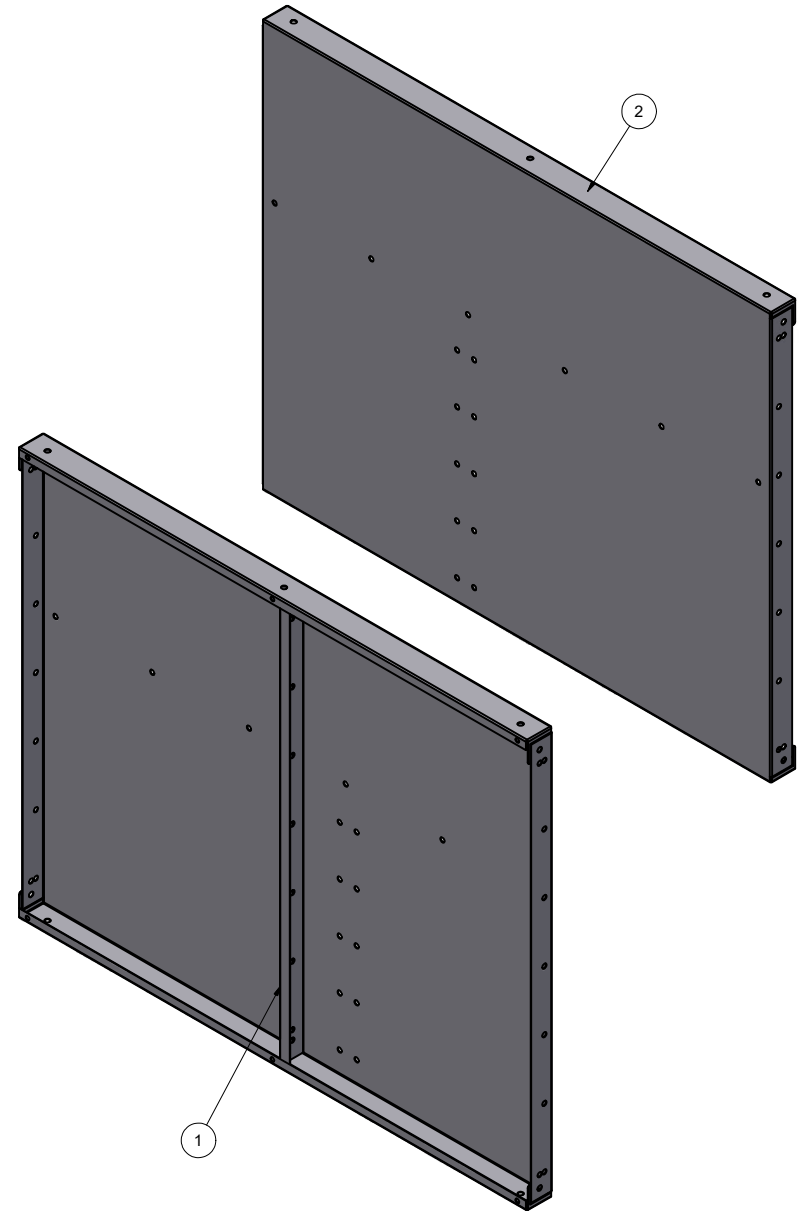
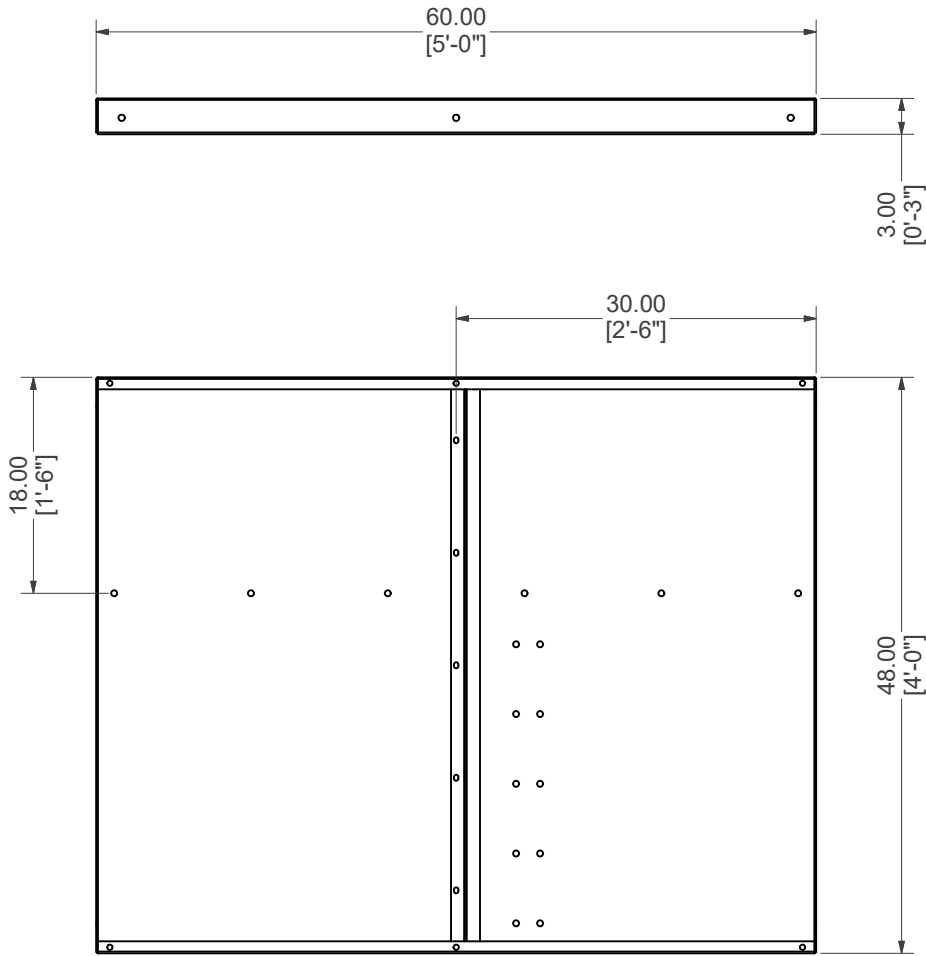

## STRAIGHT, BACK WALL, RIGHT W/ Z-RIBS

<b>PART #:</b> ESC-18336-BWR  	<b>WEIGHT:</b> 77.06 lbmass	<b>MACHINE TIME:</b> N/A	<b>FILE/DIRECTORY:</b> C:\Vault\FTW\Design\CUSTOM STEPS\ESC-18000-18999\ESC-18336.idw
	<b>TOLERANCES EXCEPT AS NOTED</b> 0/0 0.0 0.00 0.000 0' ±1/8 ±0.25 ±0.0625 ±0.03125 ±1/2'	<b>MATERIAL:</b>  <b>DRAWN BY:</b> SA	<b>DATE:</b> 3/14/2024  <b>SHEET:</b> 6 OF 35

Parts List			
ITEM	QTY	PART NUMBER	DESCRIPTION
1	1	48-Z-RIB	48" Z-RIB
2	1	ESC-18336-SWR	STRAIGHT, SIDE WALL, RIGHT

# WELDCODE #17

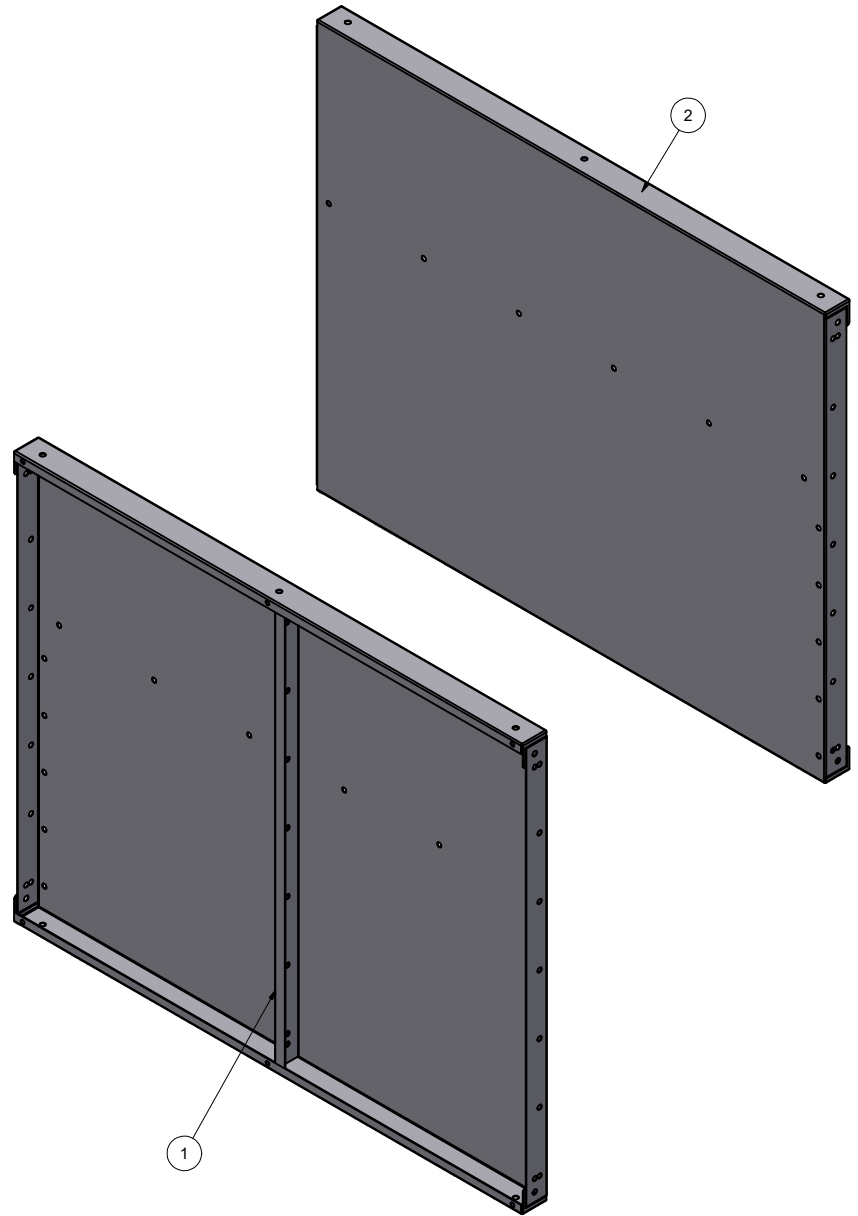
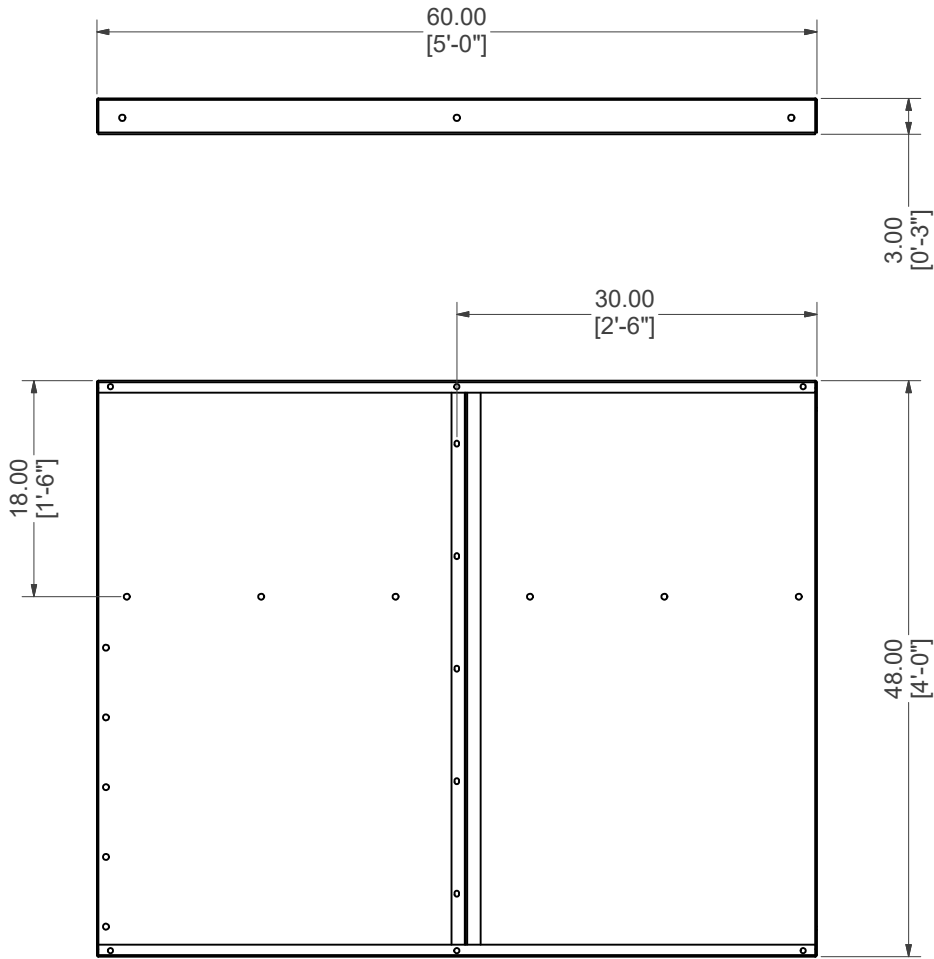

## STRAIGHT, SIDE WALL, RIGHT W/ Z-RIBS

<b>PART #:</b> ESC-18336-SWR 	<b>WEIGHT:</b> 77.08 lbmass	<b>MACHINE TIME:</b> N/A	<b>FILE/DIRECTORY:</b> C:\Vault\FTW\Design\CUSTOM STEPS\ESC-18000-18999\ESC-18336.idw
	<b>TOLERANCES EXCEPT AS NOTED</b> 0/0 0.0 0.00 0.000 0' ±1/8 ±0.25 ±0.0625 ±0.03125 ±1/2'	<b>MATERIAL:</b>  <b>DRAWN BY:</b> SA	<b>DATE:</b> 3/14/2024  <b>SHEET:</b> 7 OF 35

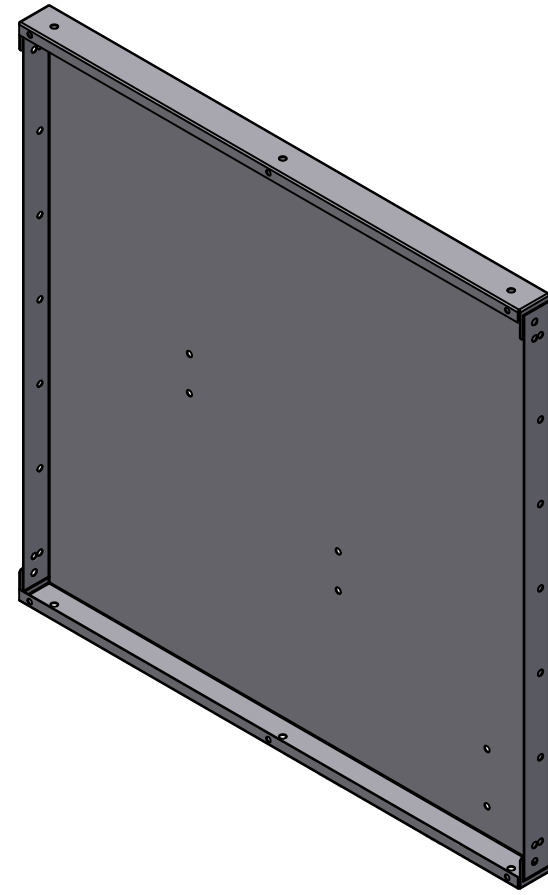
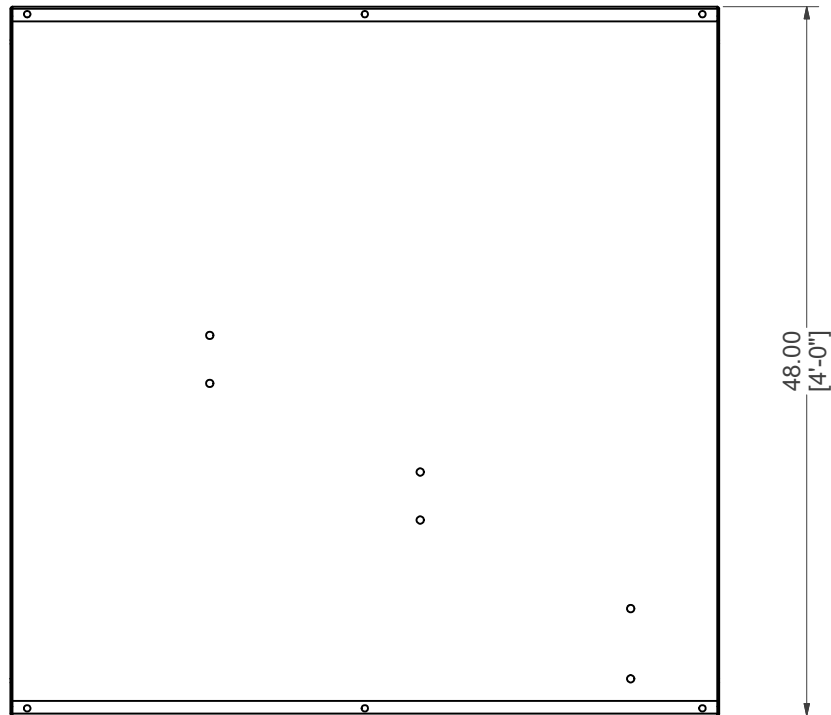
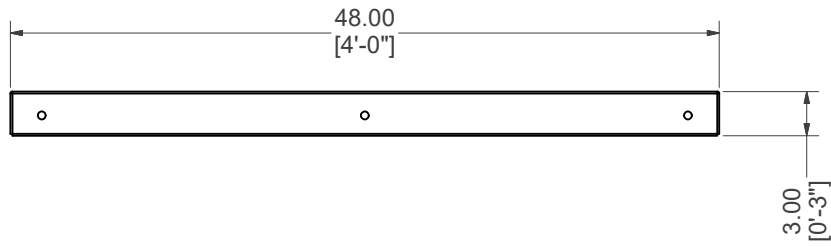

## STRAIGHT, SIDE WALL, LEFT

<b>PART #:</b> ESC-18336-SWL  	<b>WEIGHT:</b> 58.64 lbmass	<b>MACHINE TIME:</b> N/A	<b>FILE/DIRECTORY:</b> C:\Vault\FTW\Design\CUSTOM STEPS\ESC-18000-18999\ESC-18336.idw
	TOLERANCES EXCEPT AS NOTED 0/0 0.0 0.00 0.000 0' ±1/8 ±0.25 ±0.0625 ±0.03125 ±1/2'	<b>MATERIAL:</b> 14 GA. GALVANIZED	<b>DATE :</b> 3/14/2024
	<b>DRAWN BY:</b> SA	<b>SHEET :</b> 8 OF 35	



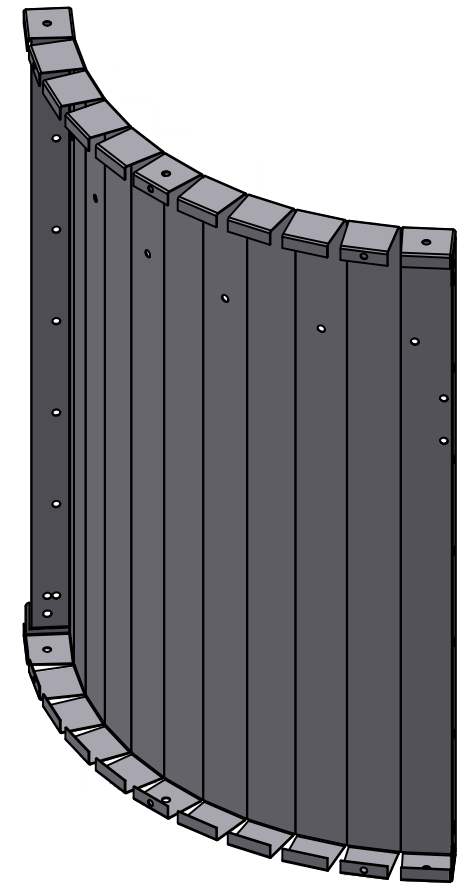
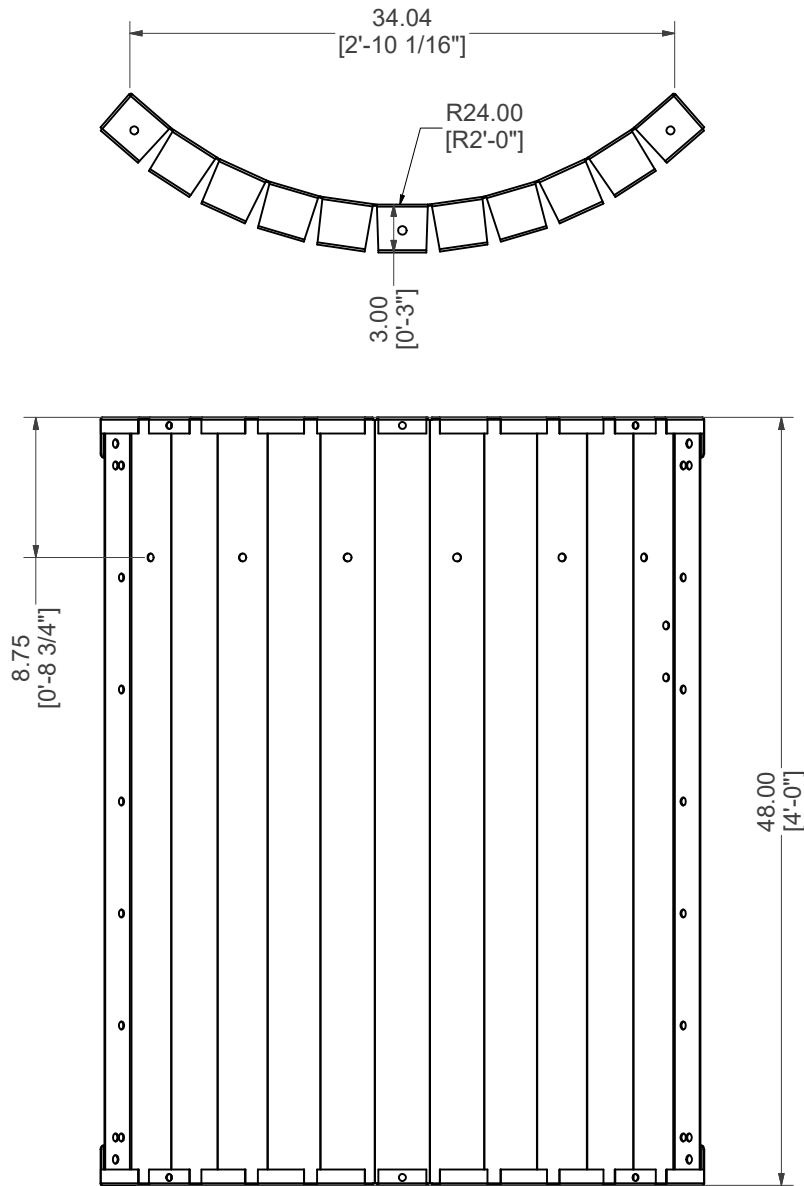

## RADIUS, CORNER WALL, LEFT

<b>PART #:</b> ESC-18336-CWL  	<b>WEIGHT:</b> 46.51 lbmass	<b>MACHINE TIME:</b> N/A	<b>FILE/DIRECTORY:</b> C:\Vault\FTW\Design\CUSTOM STEPS\ESC-18000-18999\ESC-18336.idw
	<b>TOLERANCES EXCEPT AS NOTED</b> 0/0 0.0 0.00 0.000 0' ±1/8 ±0.25 ±0.0625 ±0.03125 ±1/2'	<b>MATERIAL:</b> 14 GA. GALVANIZED	<b>DATE :</b> 3/14/2024
<b>DRAWN BY:</b> SA	<b>SHEET :</b> 9 OF 35		

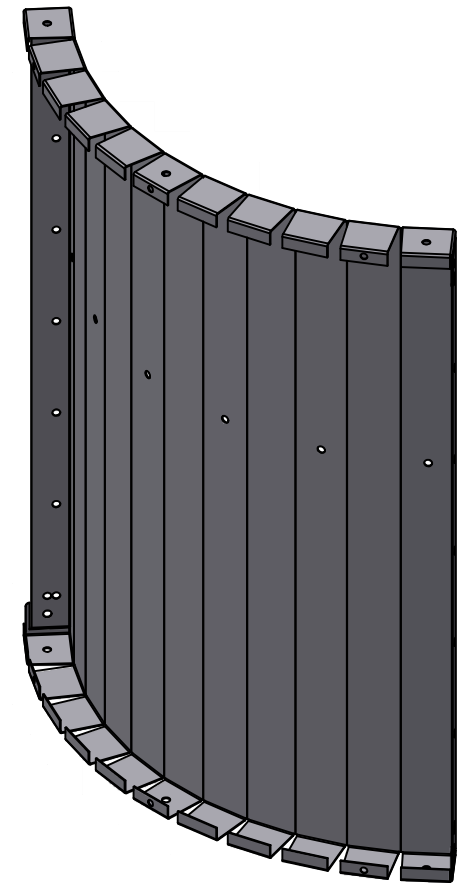
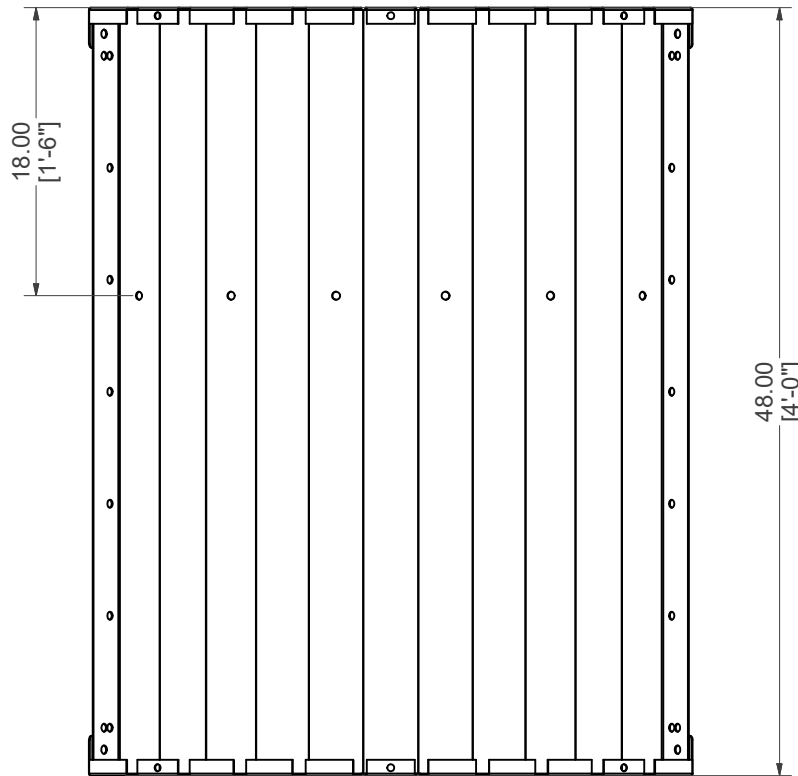
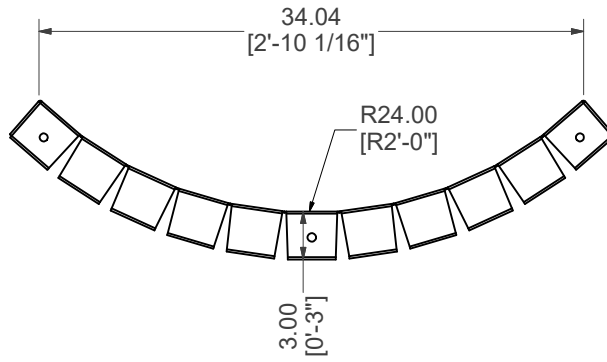

# REV. RAD, CORNER WALL, RIGHT

<b>PART #:</b> ESC-9625-CWR  	<b>WEIGHT:</b> 46.52 lbmass	<b>MACHINE TIME:</b> N/A	<b>FILE/DIRECTORY:</b> C:\Vault\FTW\Design\CUSTOM STEPS\ESC-18000-18999\ESC-18336.idw
	TOLERANCES EXCEPT AS NOTED 0/0 0.0 0.00 0.000 0' ±1/8 ±0.25 ±0.0625 ±0.03125 ±1/2'	<b>MATERIAL:</b> 14 GA. GALVANIZED	<b>DATE :</b> 3/14/2024
<b>DRAWN BY:</b> SA	<b>SHEET :</b> 10 OF 35		

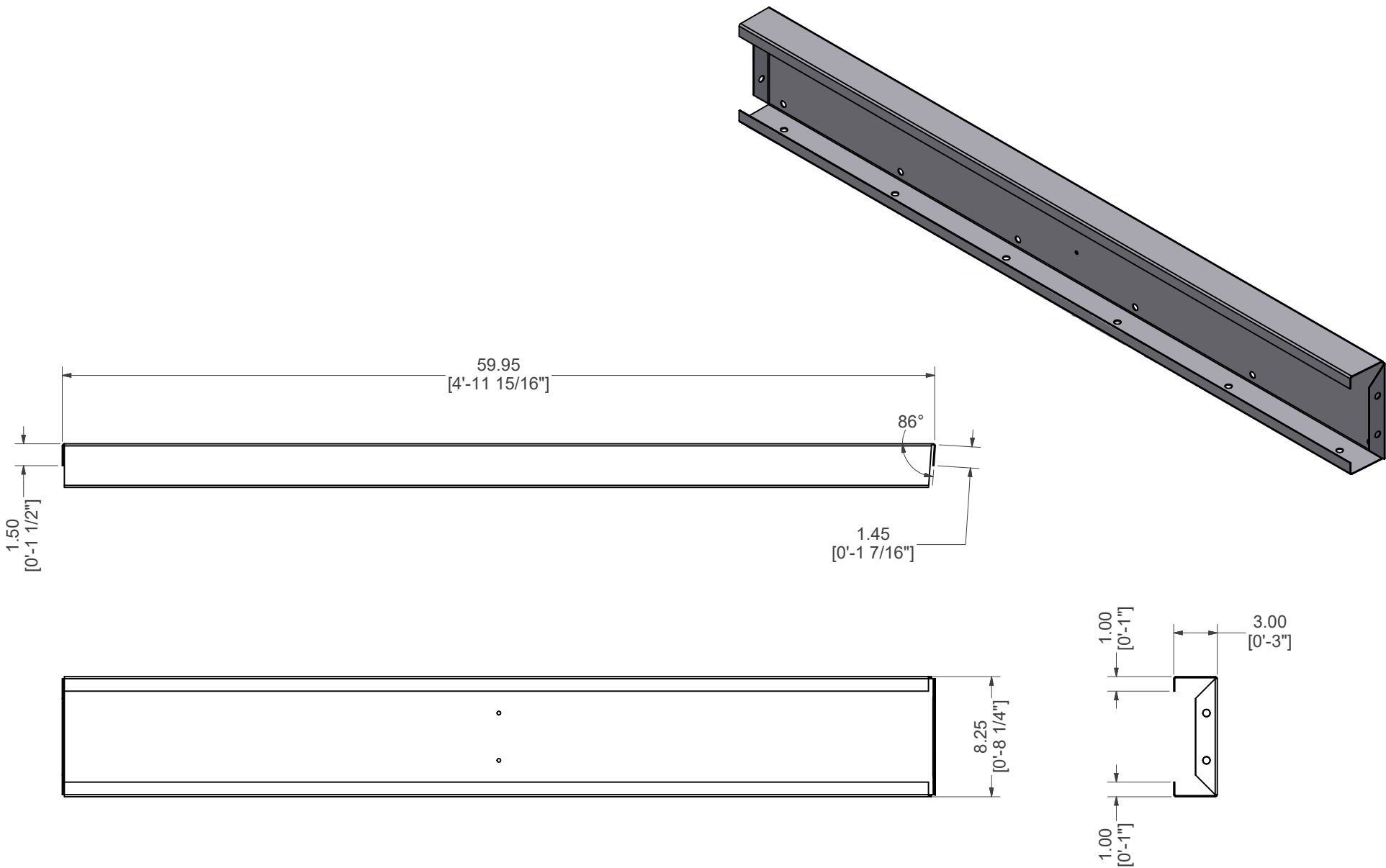

# STRAIGHT, TOP RISER, LEFT

<b>PART #:</b> ESC-18336-TRL	<b>WEIGHT:</b> 19.47 lbmass	<b>MACHINE TIME:</b> N/A	<b>FILE/DIRECTORY:</b> C:\Vault\FTW\Design\CUSTOM STEPS\ESC-18000-18999\ESC-18336.idw
	<b>TOLERANCES EXCEPT AS NOTED</b> 0/0 0.0 0.00 0.000 0' ±1/8 ±0.25 ±0.0625 ±0.03125 ±1/2'	<b>MATERIAL:</b> 14 GA. GALVANIZED  <b>DRAWN BY:</b> SA	<b>DATE:</b> 3/14/2024  <b>SHEET:</b> 11 <b>OF</b> 35
<b>NOTES:</b>			

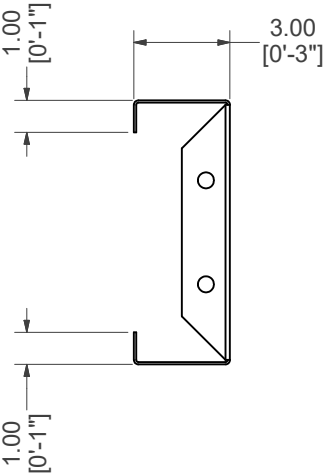
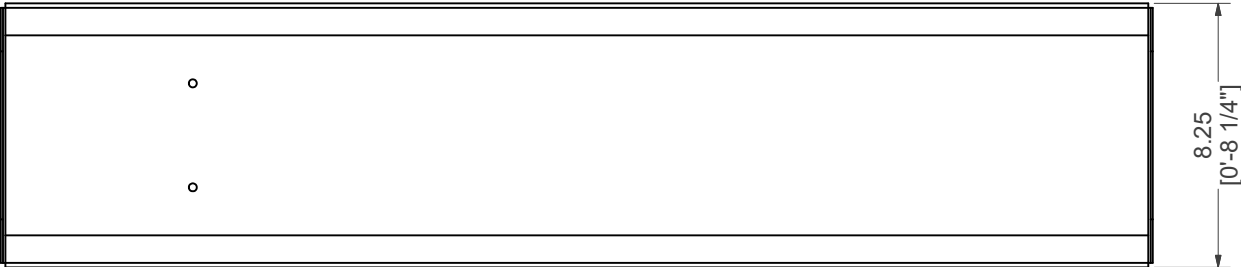
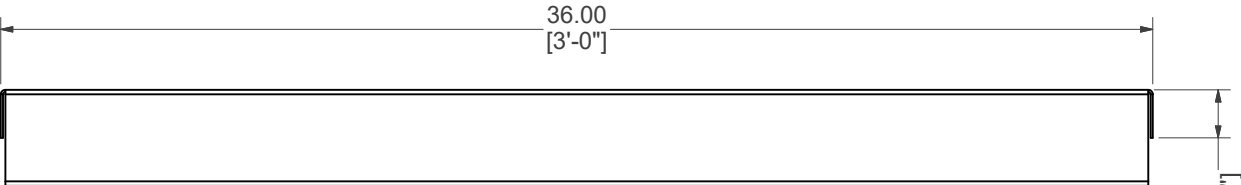
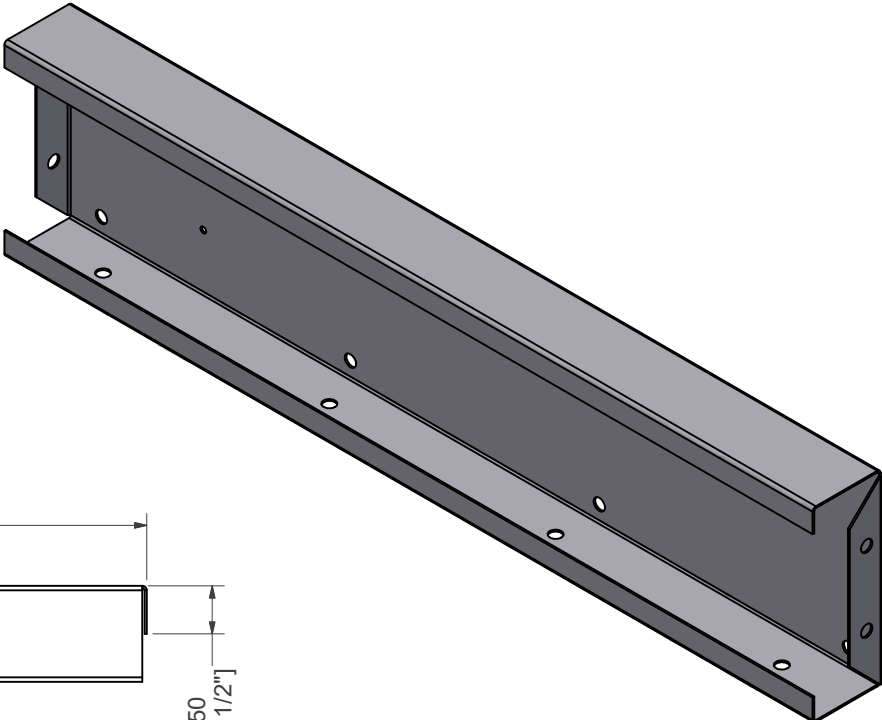

# STRAIGHT, TOP RISER, MIDDLE

<b>PART #:</b> ESC-18336-TRM	<b>WEIGHT:</b> 11.83 lbmass	<b>MACHINE TIME:</b> N/A	<b>FILE/DIRECTORY:</b> C:\Vault\FTW\Design\CUSTOM STEPS\ESC-18000-18999\ESC-18336.idw
	TOLERANCES EXCEPT AS NOTED 0/0 0.0 0.00 0.000 0' ±1/8 ±0.25 ±0.0625 ±0.03125 ±1/2'	<b>MATERIAL:</b> 14 GA. GALVANIZED  <b>DRAWN BY:</b> SA	<b>DATE :</b> 3/14/2024  <b>SHEET :</b> 12 OF 35
<b>NOTES:</b>			

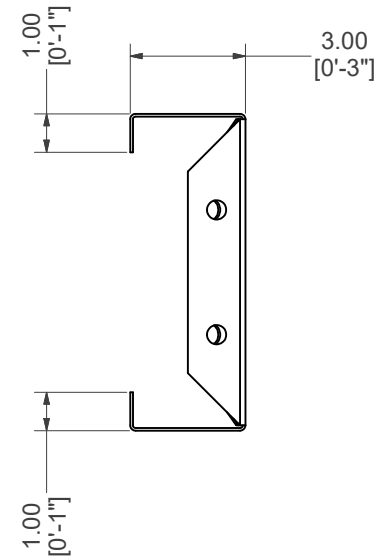
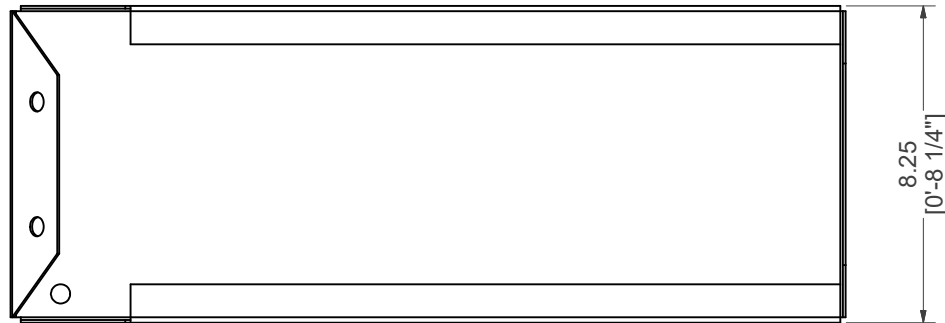
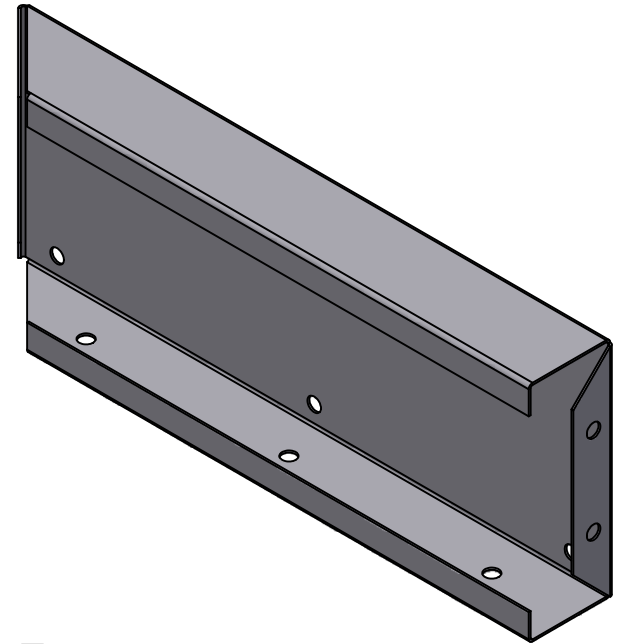
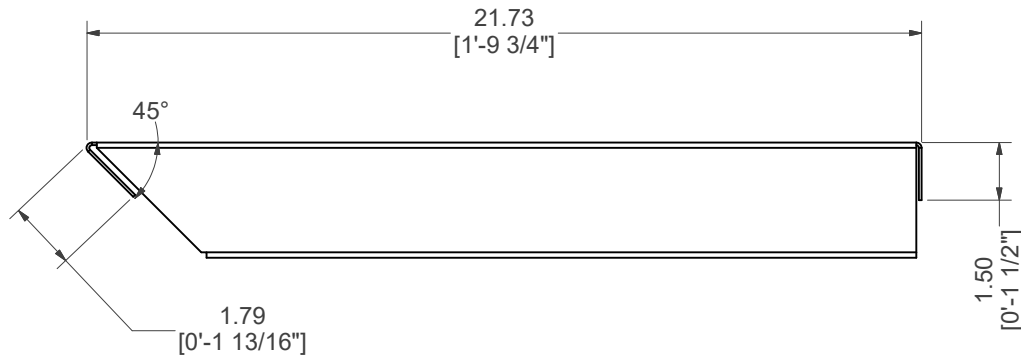

# STRAIGHT, TOP RISER, RIGHT

<b>PART #:</b> ESC-18336-TRR  	<b>WEIGHT:</b> 7.02 lbmass	<b>MACHINE TIME:</b> N/A	<b>FILE/DIRECTORY:</b> C:\Vault\FTW\Design\CUSTOM STEPS\ESC-18000-18999\ESC-18336.idw
	<b>TOLERANCES EXCEPT AS NOTED</b> 0/0 0.0 0.00 0.000 0' ±1/8 ±0.25 ±0.0625 ±0.03125 ±1/2'	<b>MATERIAL:</b> 14 GA. GALVANIZED	<b>DATE:</b> 3/14/2024
	<b>DRAWN BY:</b> SA	<b>SHEET:</b> 13 OF 35	

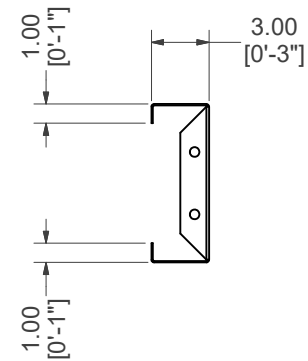
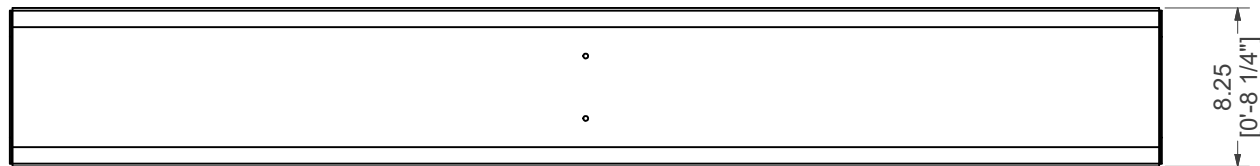
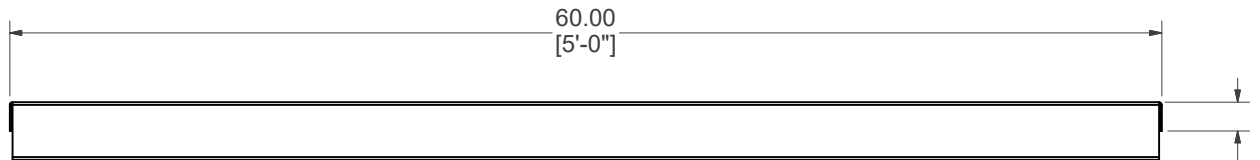
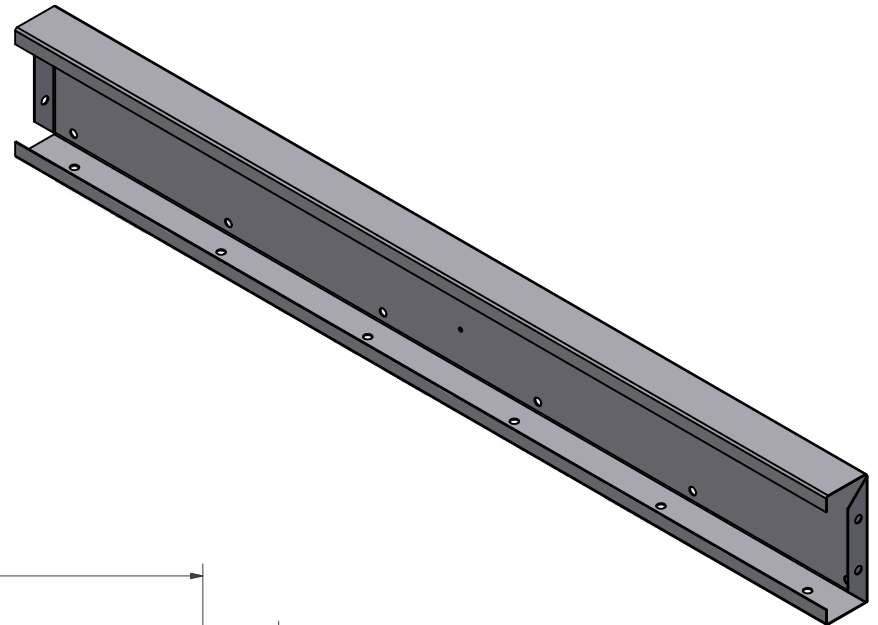

# STRAIGHT, MIDDLE RISER

<b>PART #:</b> ESC-18336-MR  	<b>WEIGHT:</b> 19.51 lbmass	<b>MACHINE TIME:</b> N/A	<b>FILE/DIRECTORY:</b> C:\Vault\FTW\Design\CUSTOM STEPS\ESC-18000-18999\ESC-18336.idw	
	<b>MATERIAL:</b> 14 GA. GALVANIZED		<b>DATE :</b> 3/14/2024	<b>NOTES:</b>
<b>TOLERANCES EXCEPT AS NOTED</b> 0/0 0.0 0.00 0.000 0' ±1/8 ±0.25 ±0.0625 ±0.03125 ±1/2'		<b>DRAWN BY:</b> SA	<b>SHEET :</b> 14 OF 35	

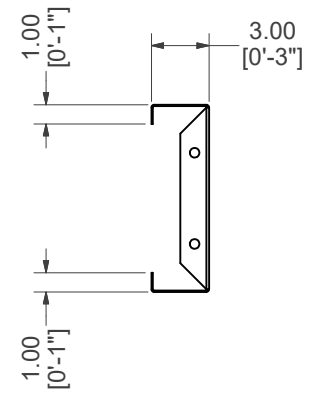
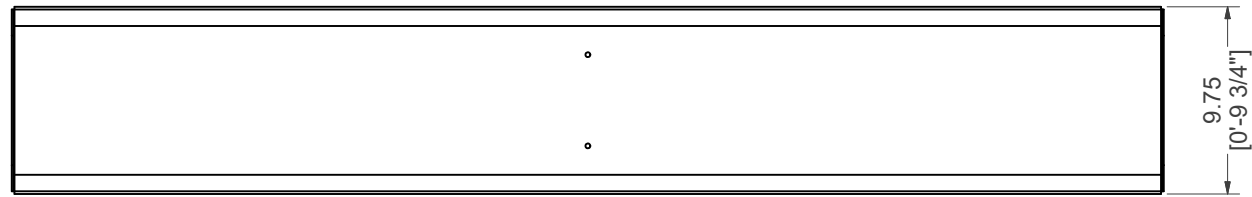
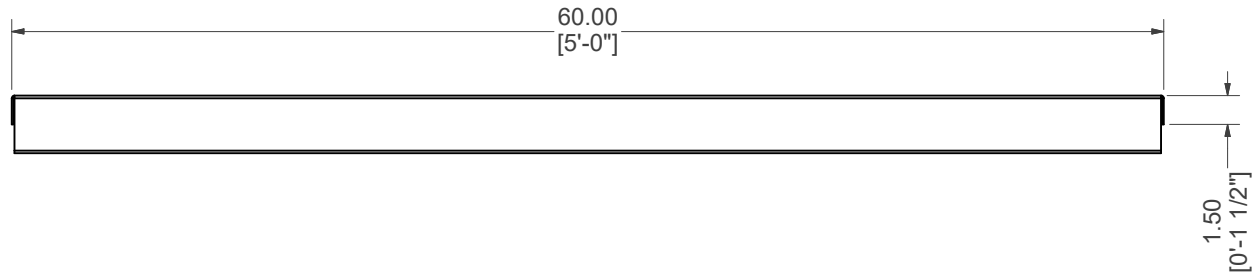
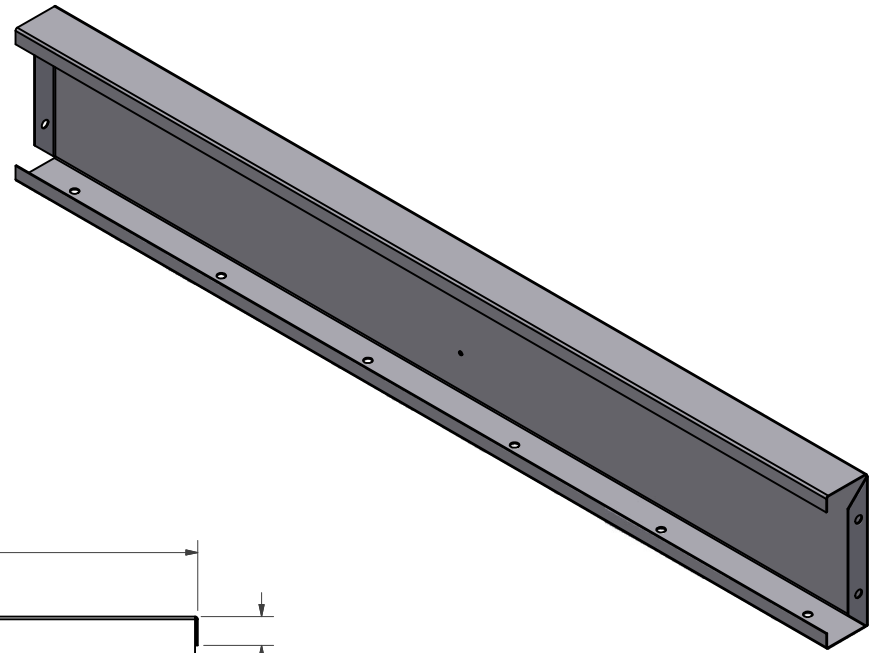

# STRAIGHT, BOTTOM RISER, LEFT

<b>PART #:</b> ESC-18336-BRL	<b>WEIGHT:</b> 21.45 lbmass	<b>MACHINE TIME:</b> N/A	<b>FILE/DIRECTORY:</b> C:\Vault\FTW\Design\CUSTOM STEPS\ESC-18000-18999\ESC-18336.idw	
	<b>TOLERANCES EXCEPT AS NOTED</b> 0/0 0.0 0.00 0.000 0' ±1/8 ±0.25 ±0.0625 ±0.03125 ±1/2'	<b>MATERIAL:</b> 14 GA. GALVANIZED	<b>DATE :</b> 3/14/2024	<b>NOTES:</b>
		<b>DRAWN BY:</b> SA	<b>SHEET :</b> 15 OF 35	

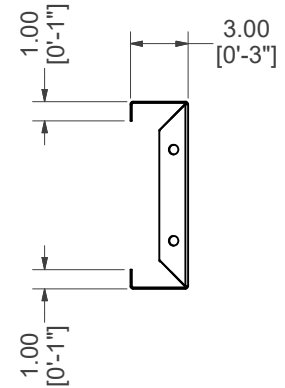
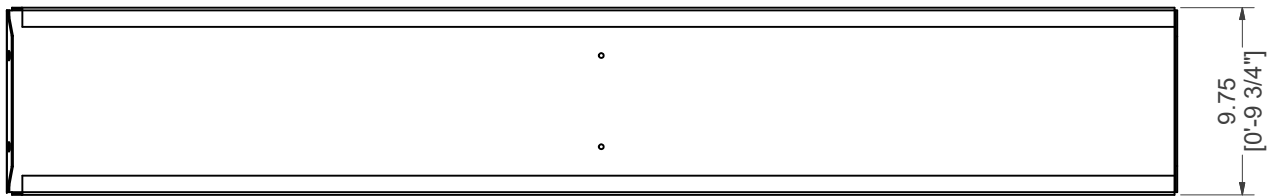
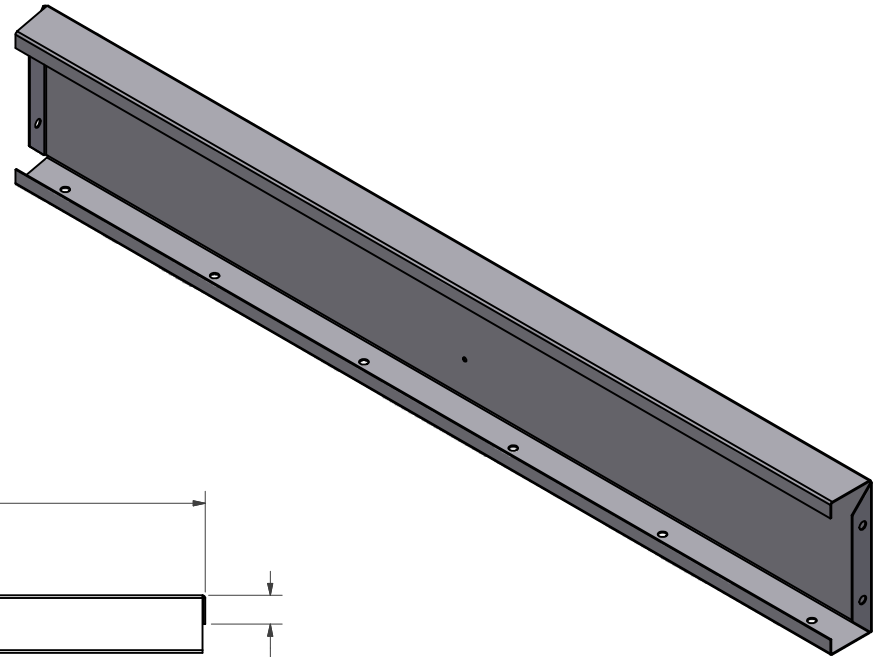
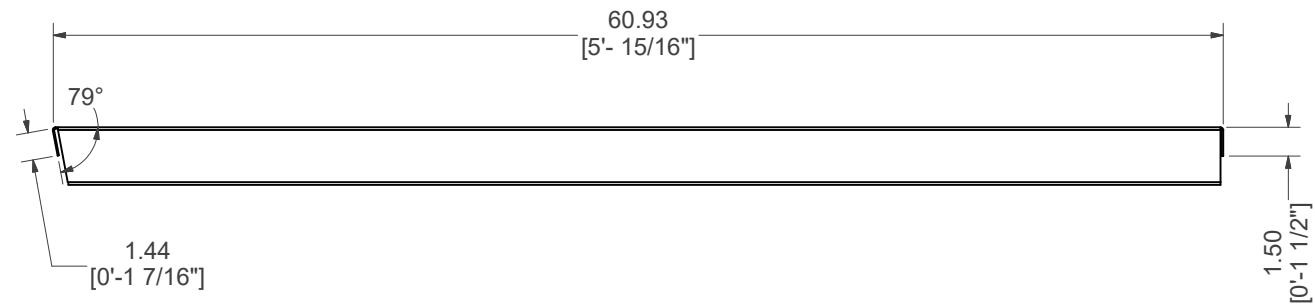

# STRAIGHT, BOTTOM RISER, RIGHT

**PART #:** ESC-18336-BRR

**WEIGHT:**  
21.72 lbmass

**MACHINE TIME:**  
N/A

**FILE/DIRECTORY:**

C:\Vault\FTW\Design\CUSTOM STEPS\ESC-18000-18999\ESC-18336.idw



TOLERANCES EXCEPT AS NOTED  
0/0 0.0 0.00 0.000 0'  
±1/8 ±0.25 ±0.0625 ±0.03125 ±1/2'

**MATERIAL:**  
14 GA. GALVANIZED

**DATE :** 3/14/2024

**NOTES:**

**DRAWN BY:** SA

**SHEET :** 16 OF 35



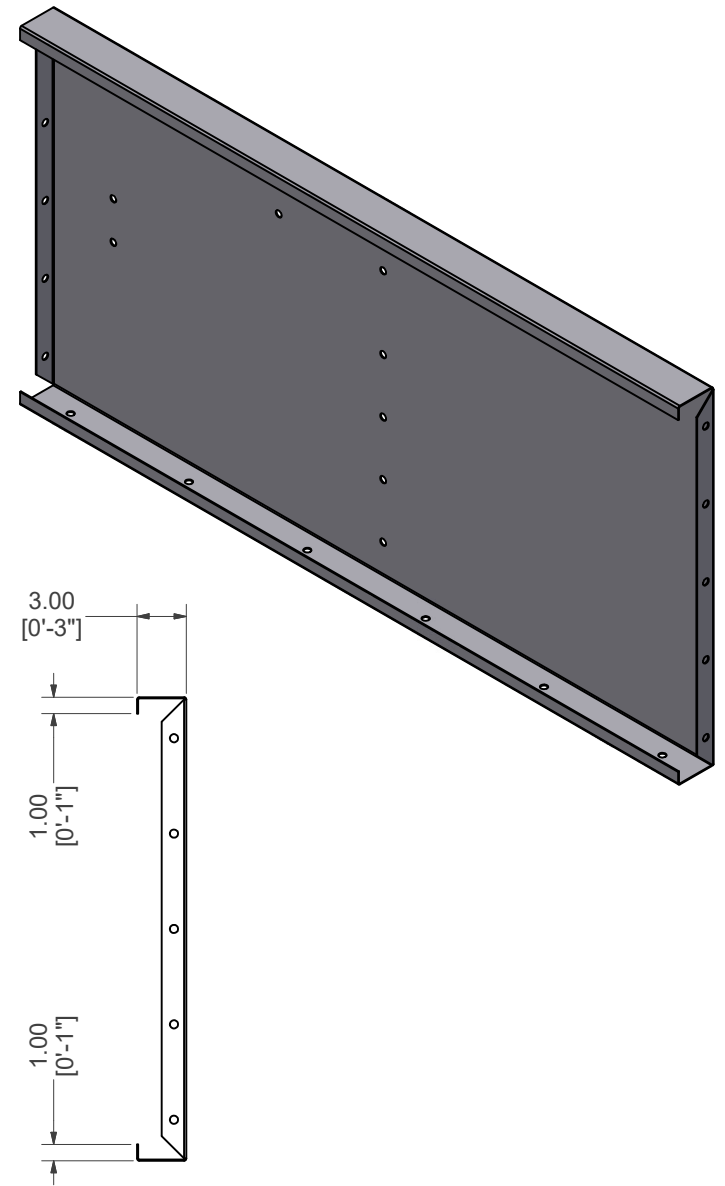
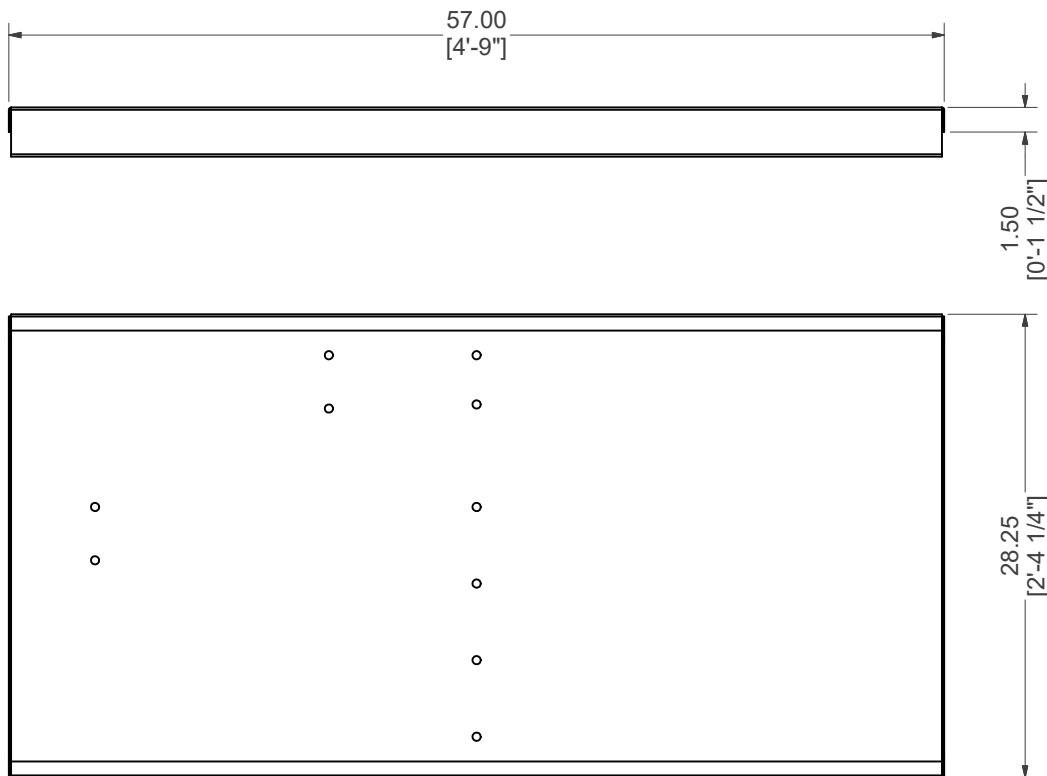

# STRAIGHT, SUNLEDGE RISER, BACK

<b>PART #:</b> ESC-18336-SRB  	<b>WEIGHT:</b> 42.80 lbmass	<b>MACHINE TIME:</b> N/A	<b>FILE/DIRECTORY:</b> C:\Vault\FTW\Design\CUSTOM STEPS\ESC-18000-18999\ESC-18336.idw
	TOLERANCES EXCEPT AS NOTED 0/0 0.0 0.00 0.000 0' ±1/8 ±0.25 ±0.0625 ±0.03125 ±1/2'	<b>MATERIAL:</b> 14 GA. GALVANIZED	<b>DATE :</b> 3/14/2024
<b>DRAWN BY:</b> SA	<b>SHEET :</b> 17 OF 35		

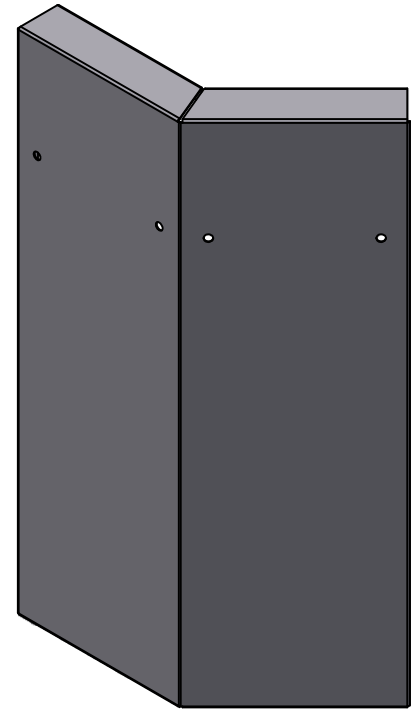
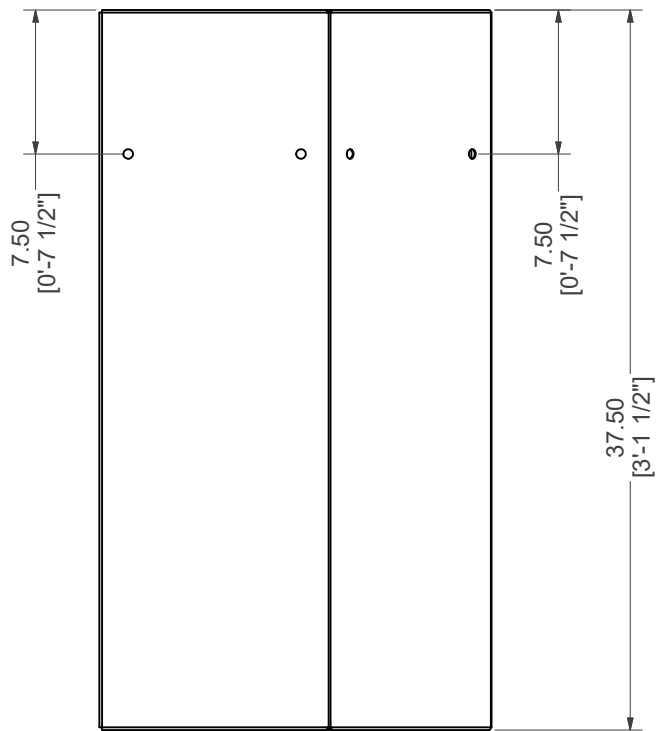
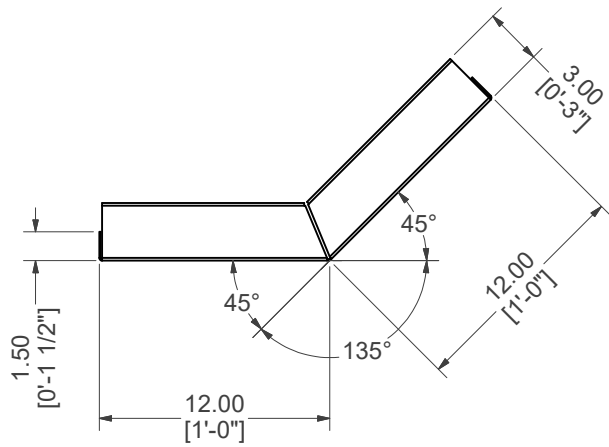

# STR REV, TOP RISER

<b>PART #:</b> ESC-18336-SRTR 	<b>WEIGHT:</b> 23.56 lbmass	<b>MACHINE TIME:</b> N/A	<b>FILE/DIRECTORY:</b> C:\Vault\FTW\Design\CUSTOM STEPS\ESC-18000-18999\ESC-18336.idw
	TOLERANCES EXCEPT AS NOTED 0/0 0.0 0.00 0.000 0' ±1/8 ±0.25 ±0.0625 ±0.03125 ±1/2'	<b>MATERIAL:</b> 14 GA. GALVANIZED	<b>DATE :</b> 3/14/2024
<b>DRAWN BY:</b> SA	<b>SHEET :</b> 18 OF 35		

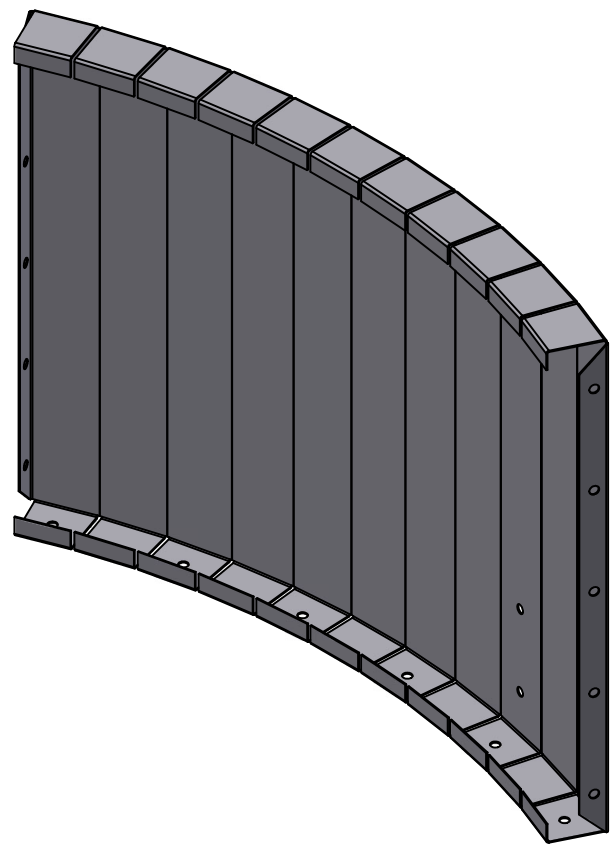
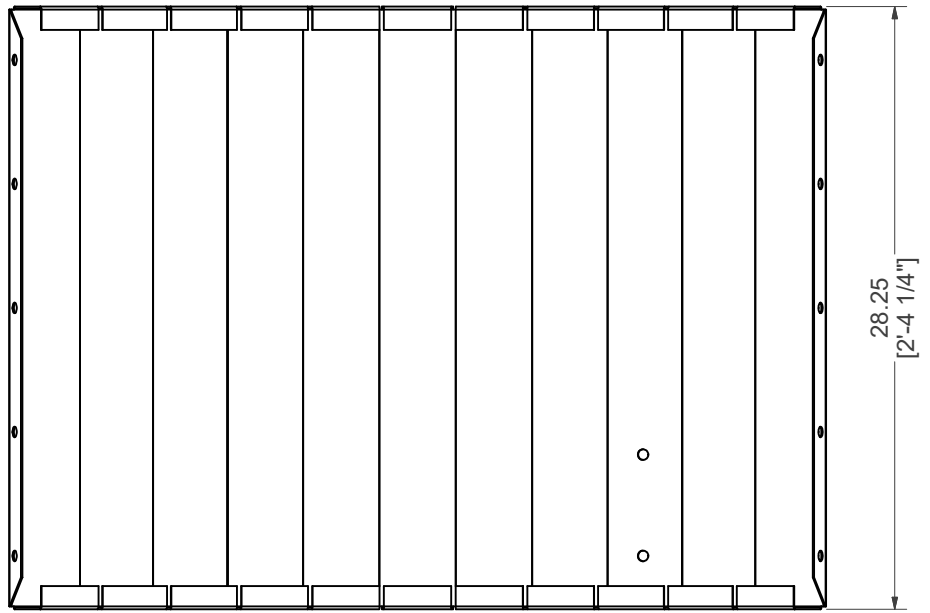
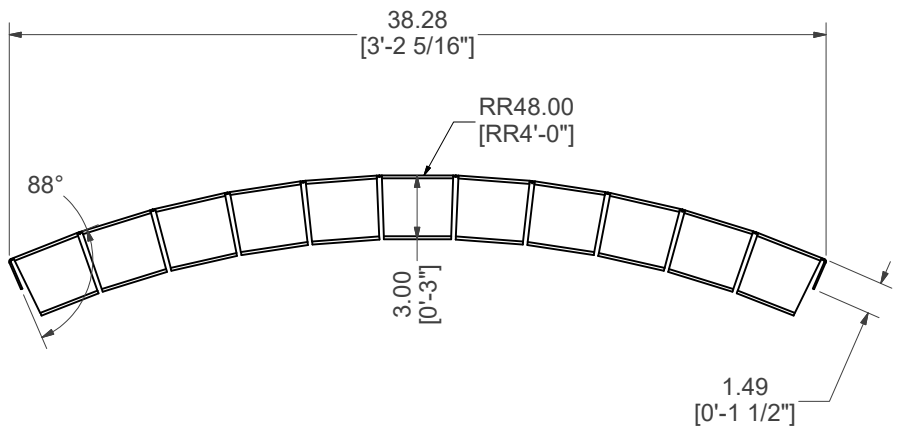

# REV RAD, SUNLEDGE RISER, LEFT

<b>PART #:</b> ESC-18336-SRL  	<b>WEIGHT:</b> 29.53 lbmass	<b>MACHINE TIME:</b> N/A	<b>FILE/DIRECTORY:</b> C:\Vault\FTWDesign\CUSTOM STEPS\ESC-18000-18999\ESC-18336.idw
	TOLERANCES EXCEPT AS NOTED 0/0 0.0 0.00 0.000 0' ±1/8 ±0.25 ±0.0625 ±0.03125 ±1/2'	<b>MATERIAL:</b> 14 GA. GALVANIZED	<b>DATE:</b> 3/14/2024
<b>DRAWN BY:</b> SA	<b>SHEET:</b> 19 OF 35		

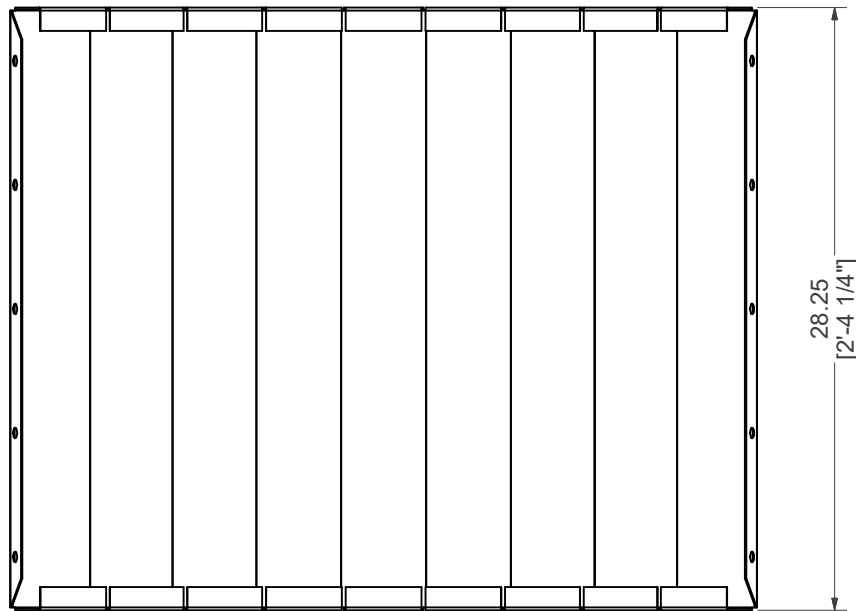
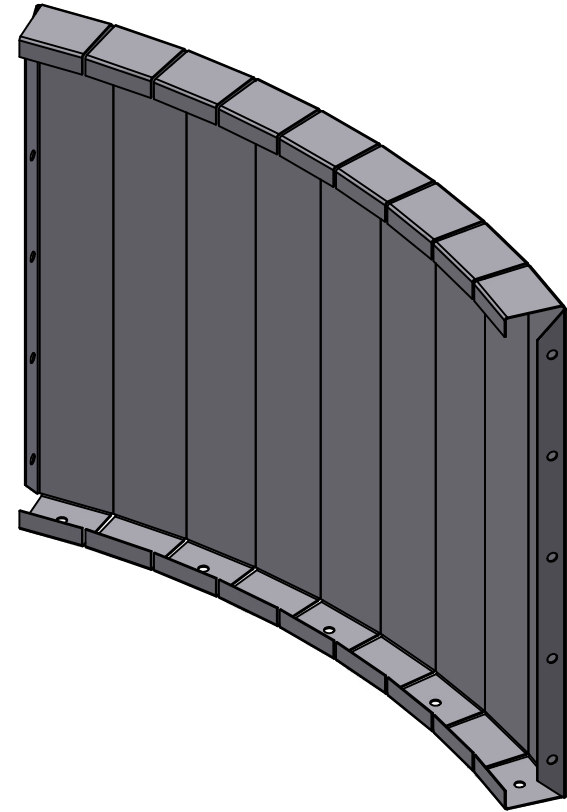
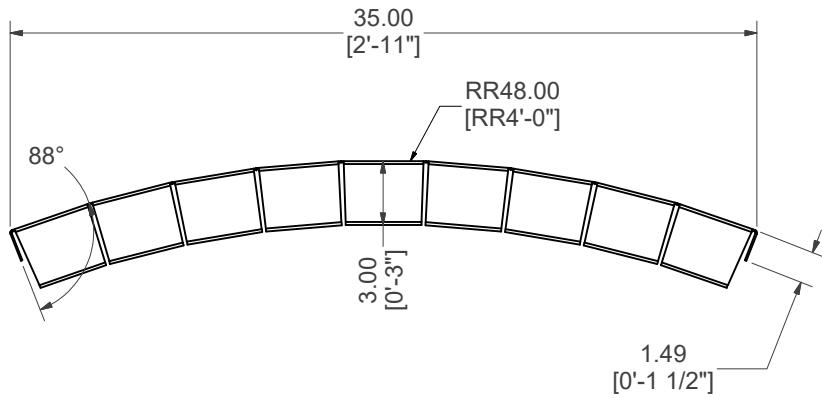

# REV RAD, SUNLEDGE RISER, MIDDLE

<b>PART #:</b> ESC-9625-SRM  	<b>WEIGHT:</b> 27.06 lbmass	<b>MACHINE TIME:</b> N/A	<b>FILE/DIRECTORY:</b> C:\Vault\FTWDesign\CUSTOM STEPS\ESC-18000-18999\ESC-18336.idw
	TOLERANCES EXCEPT AS NOTED 0/0 0.0 0.00 0.000 0' ±1/8 ±0.25 ±0.0625 ±0.03125 ±1/2'	<b>MATERIAL:</b> 14 GA. GALVANIZED	<b>DATE :</b> 3/14/2024
<b>DRAWN BY:</b> SA	<b>SHEET :</b> 20 OF 35		

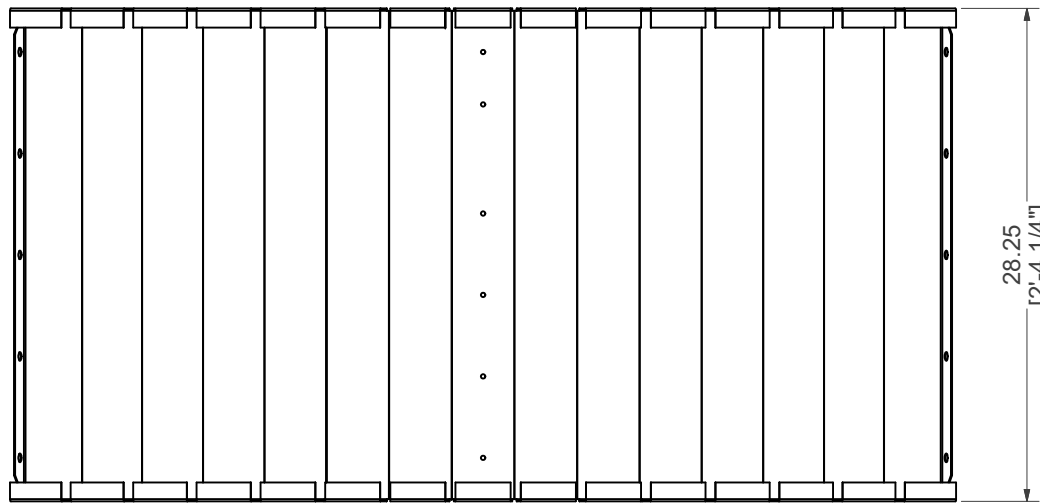
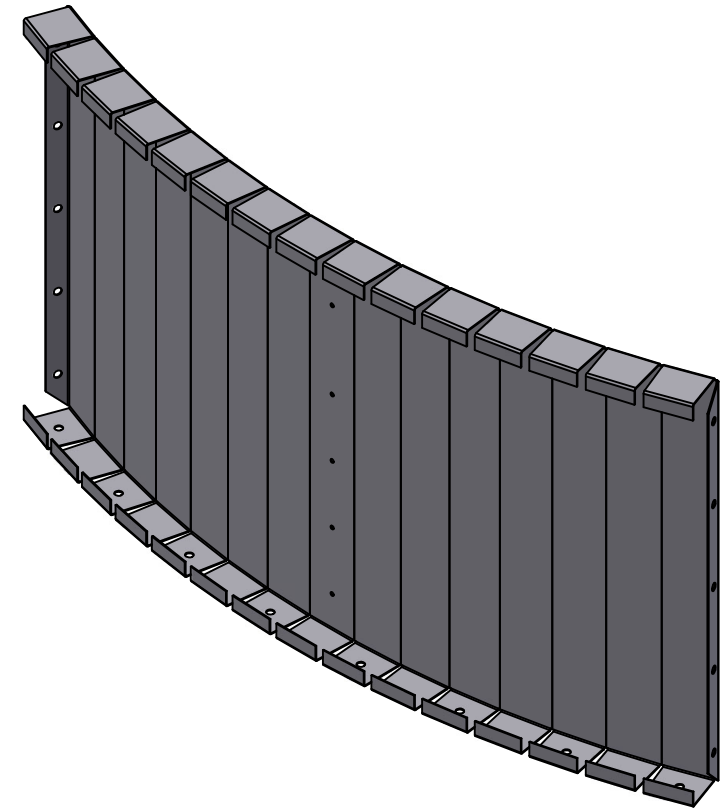
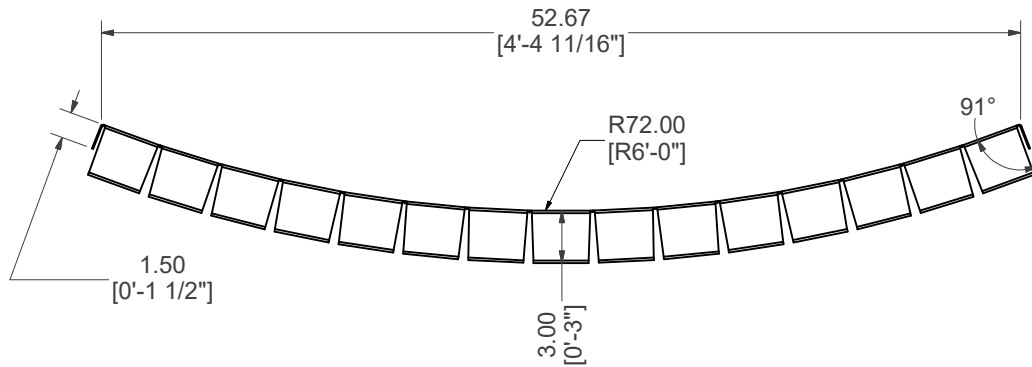

# RADIUS, SUNLEDGE RISER, RIGHT

<b>PART #:</b> ESC-9625-SRR  	<b>WEIGHT:</b> 39.93 lbmass	<b>MACHINE TIME:</b> N/A	<b>FILE/DIRECTORY:</b> C:\Vault\FTW\Design\CUSTOM STEPS\ESC-18000-18999\ESC-18336.idw
	TOLERANCES EXCEPT AS NOTED 0/0 0.0 0.00 0.000 0' ±1/8 ±0.25 ±0.0625 ±0.03125 ±1/2'	<b>MATERIAL:</b> 14 GA. GALVANIZED	<b>DATE:</b> 3/14/2024
<b>DRAWN BY:</b> SA	<b>SHEET:</b> 21 OF 35		

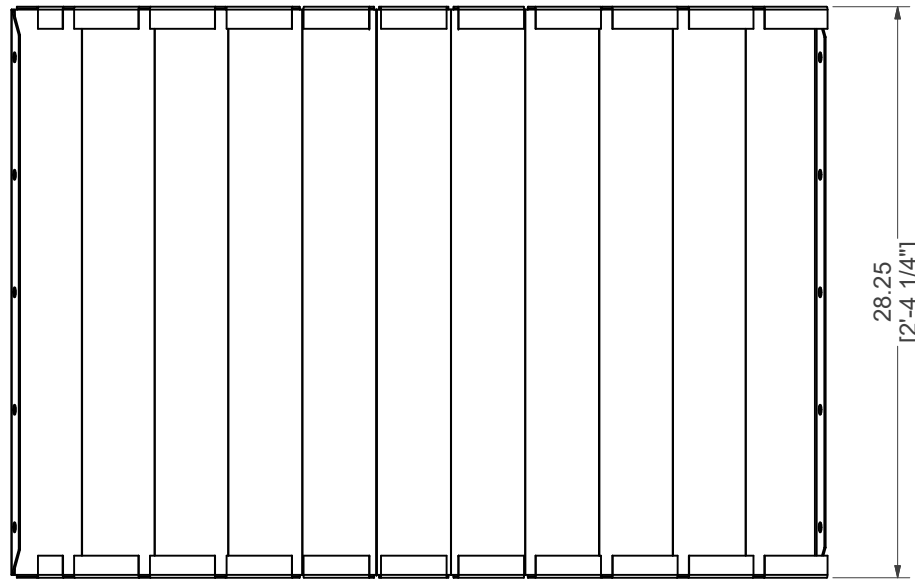
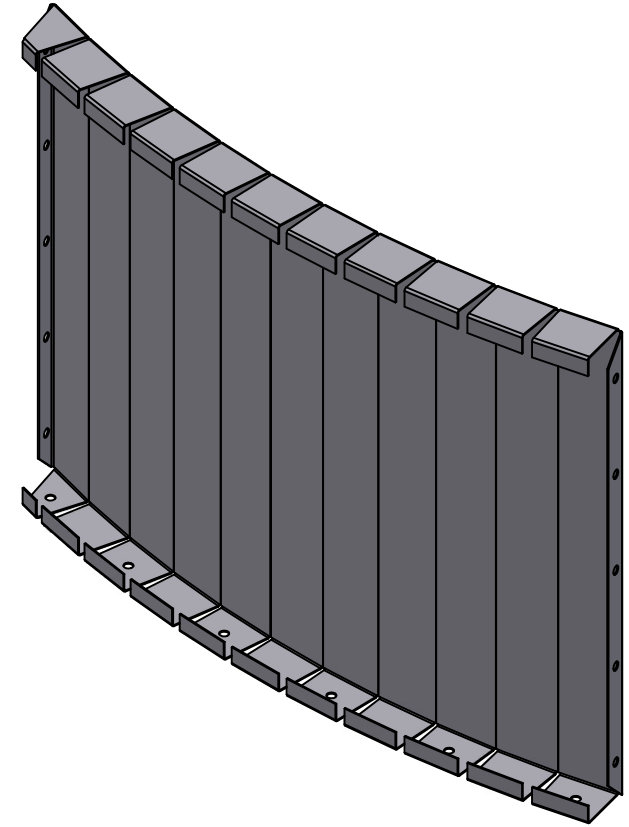
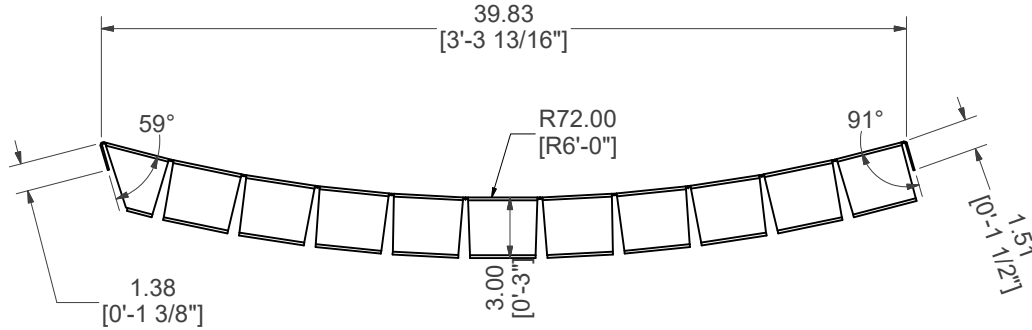

## RADIUS, SUNLEDGE RISER, RIGHT, END

<b>PART #:</b> ESC-9625-SRRE	<b>WEIGHT:</b> 30.07 lbmass	<b>MACHINE TIME:</b> N/A	<b>FILE/DIRECTORY:</b> C:\Vault\FTW\Design\CUSTOM STEPS\ESC-18000-18999\ESC-18336.idw	
	TOLERANCES EXCEPT AS NOTED	<b>MATERIAL:</b> 14 GA. GALVANIZED	<b>DATE :</b> 3/14/2024	<b>NOTES:</b>
	0/0 0.0 0.00 0.000 0' ±1/8 ±0.25 ±0.0625 ±0.03125 ±1/2"	<b>DRAWN BY:</b> SA	<b>SHEET :</b> 22 <b>OF</b> 35	

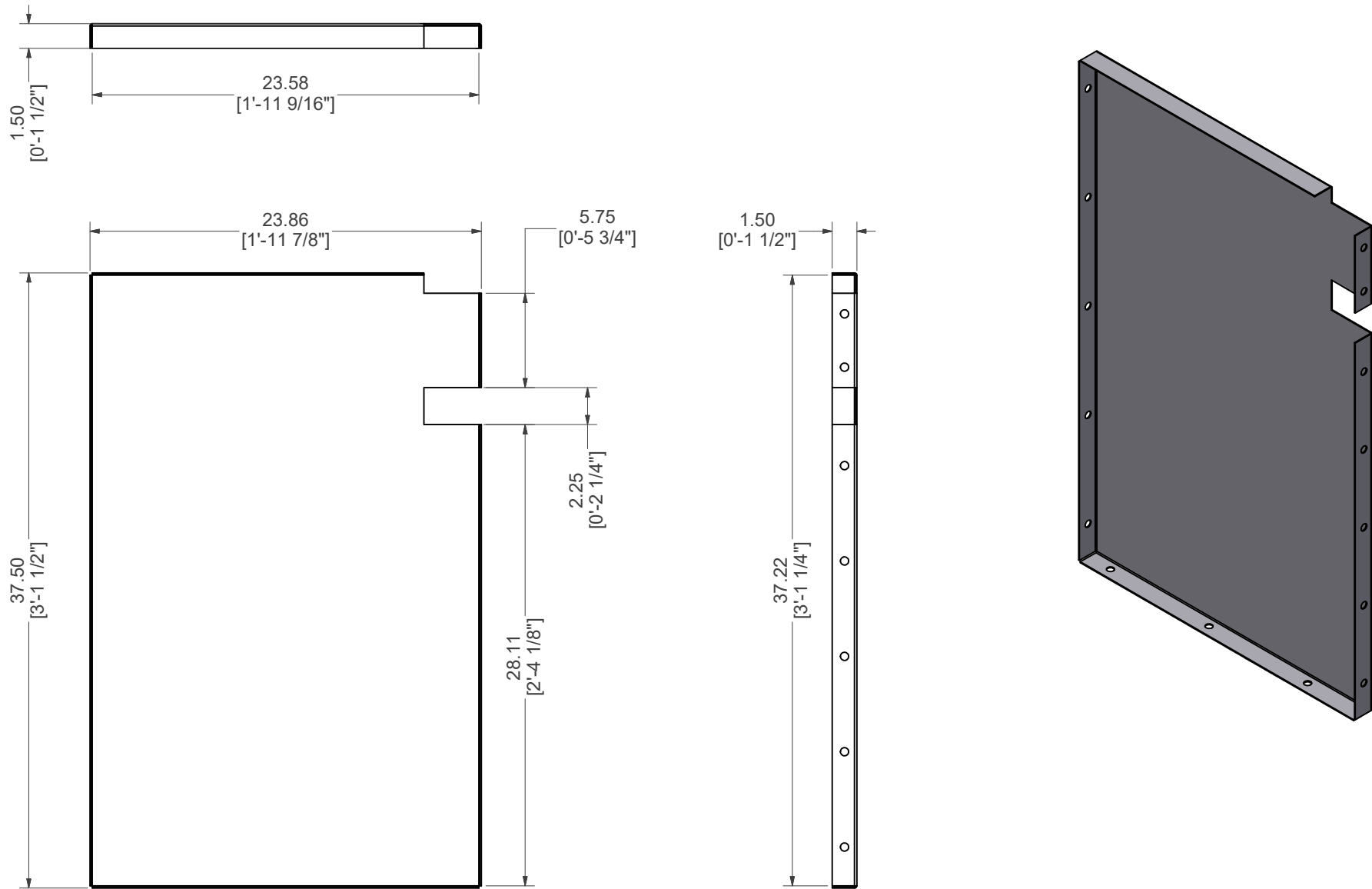

# BRACE, TOP RISER MIDDLE SUPPORT

<b>PART #:</b> ESC-18336-TRMS	<b>WEIGHT:</b> 21.10 lbmass	<b>MACHINE TIME:</b> N/A	<b>FILE/DIRECTORY:</b> C:\Vault\FTW\Design\CUSTOM STEPS\ESC-18000-18999\ESC-18336.idw	
	TOLERANCES EXCEPT AS NOTED	<b>MATERIAL:</b> 14 GA. GALVANIZED	<b>DATE :</b> 3/14/2024	<b>NOTES:</b>
	0/0 0.0 0.00 0.000 0' ±1/8 ±0.25 ±0.0625 ±0.03125 ±1/2'	<b>DRAWN BY:</b> SA	<b>SHEET :</b> 23 OF 35	

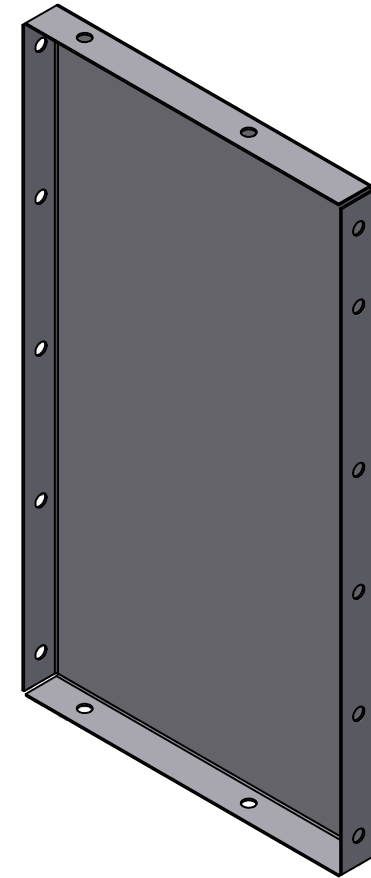
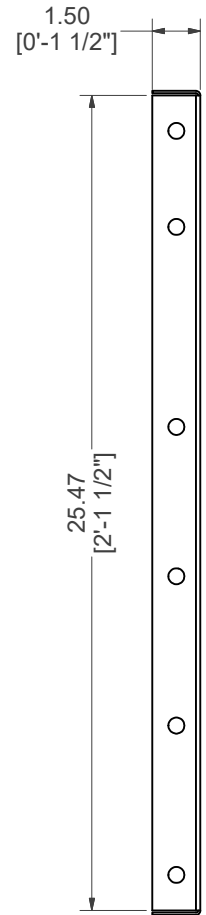
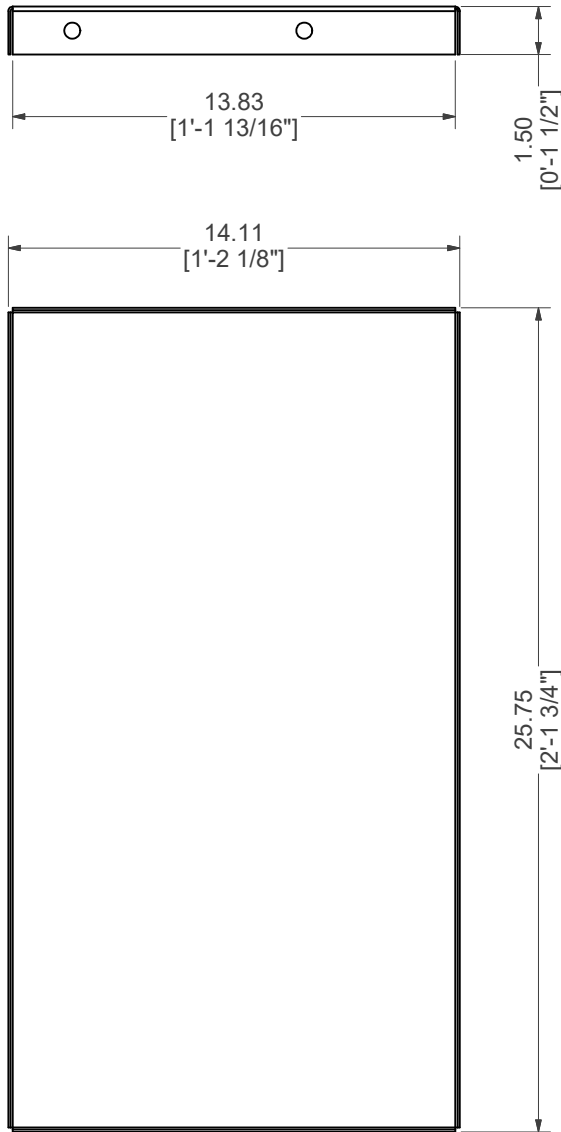

## BRACE, TOP MIDDLE RISER SUPPORT

<b>PART #:</b> ESC-8029-TMRS  	<b>WEIGHT:</b> 9.53 lbmass	<b>MACHINE TIME:</b> N/A	<b>FILE/DIRECTORY:</b> C:\Vault\FTWDesign\CUSTOM STEPS\ESC-18000-18999\ESC-18336.idw
	TOLERANCES EXCEPT AS NOTED 0/0 0.0 0.00 0.000 0' ±1/8 ±0.25 ±0.0625 ±0.03125 ±1/2'	<b>MATERIAL:</b> 14 GA. GALVANIZED	<b>DATE :</b> 3/14/2024
<b>DRAWN BY:</b> SA	<b>SHEET :</b> 24 OF 35		



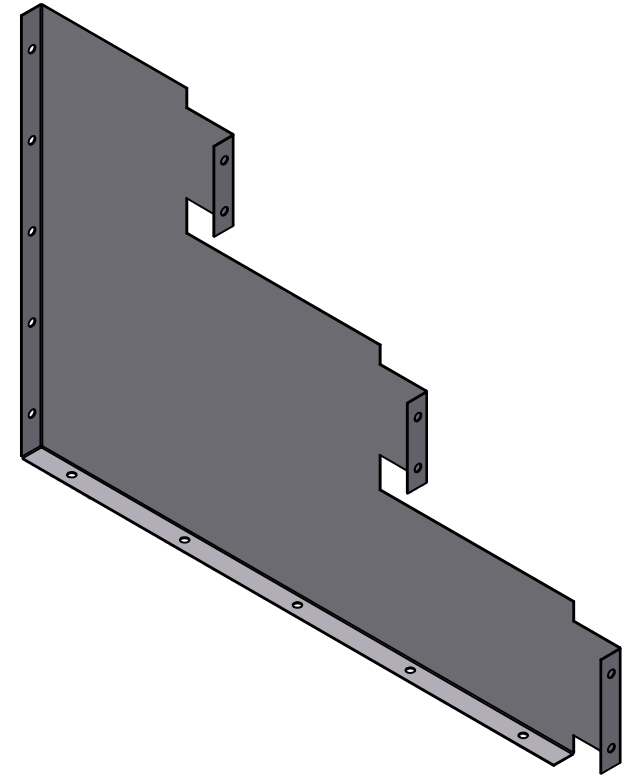
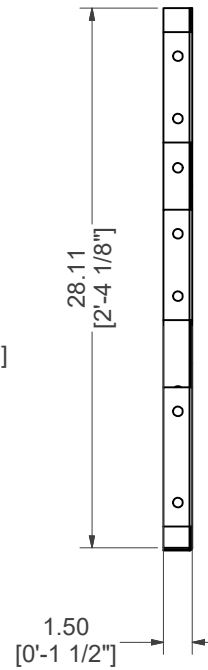
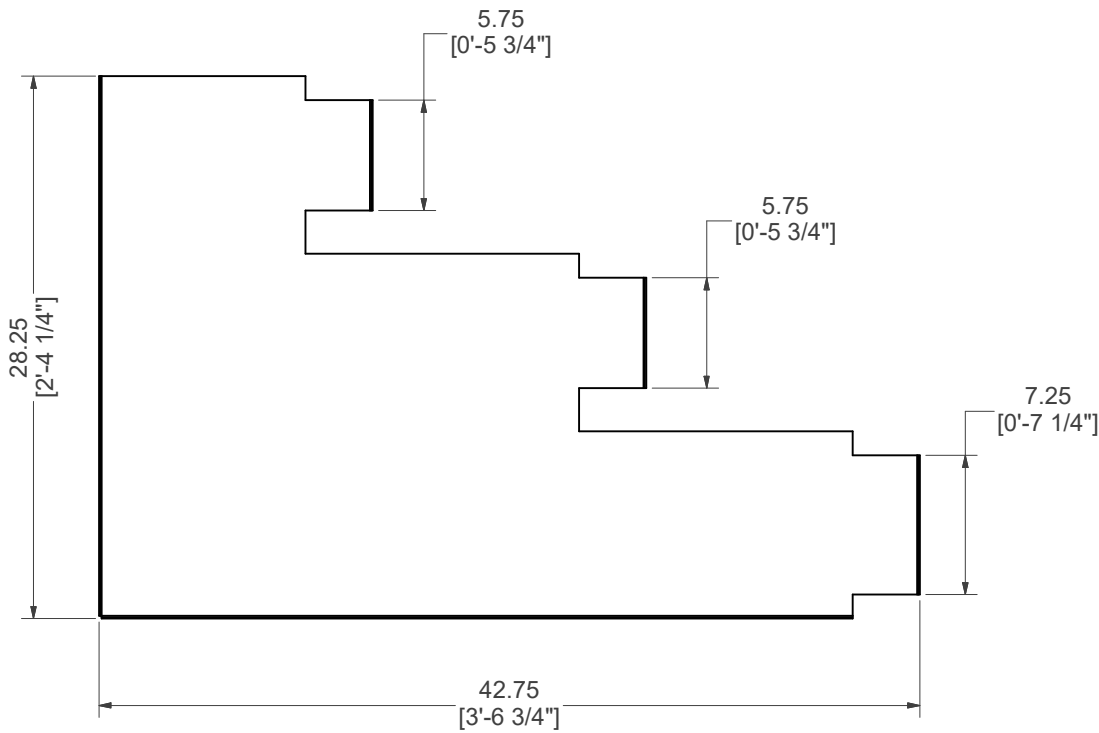
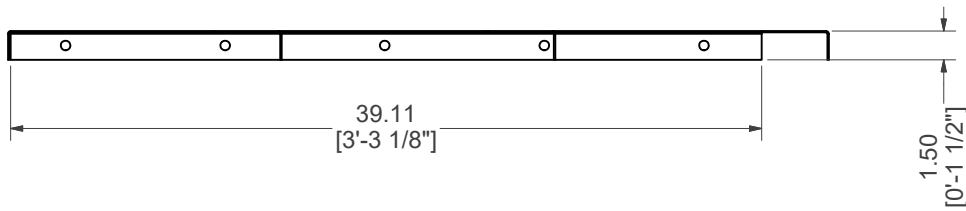

# BRACE, 3-RISER SUPPORT

<b>PART #:</b> ESC-18336-CSB  	<b>WEIGHT:</b> 18.18 lbmass	<b>MACHINE TIME:</b> N/A	<b>FILE/DIRECTORY:</b> C:\Vault\FTW\Design\CUSTOM STEPS\ESC-18000-18999\ESC-18336.idw
	TOLERANCES EXCEPT AS NOTED 0/0 0.0 0.00 0.000 0' ±1/8 ±0.25 ±0.0625 ±0.03125 ±1/2'	<b>MATERIAL:</b> 14 GA. GALVANIZED	<b>DATE:</b> 3/14/2024
<b>DRAWN BY:</b> SA	<b>SHEET:</b> 25 OF 35		

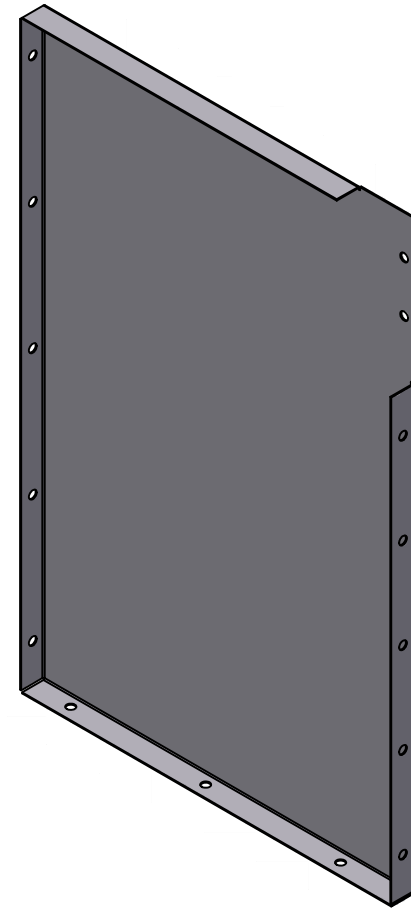
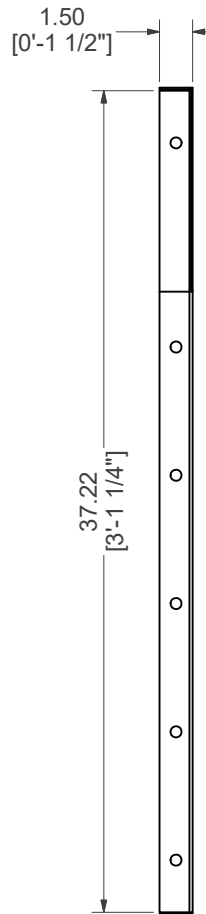
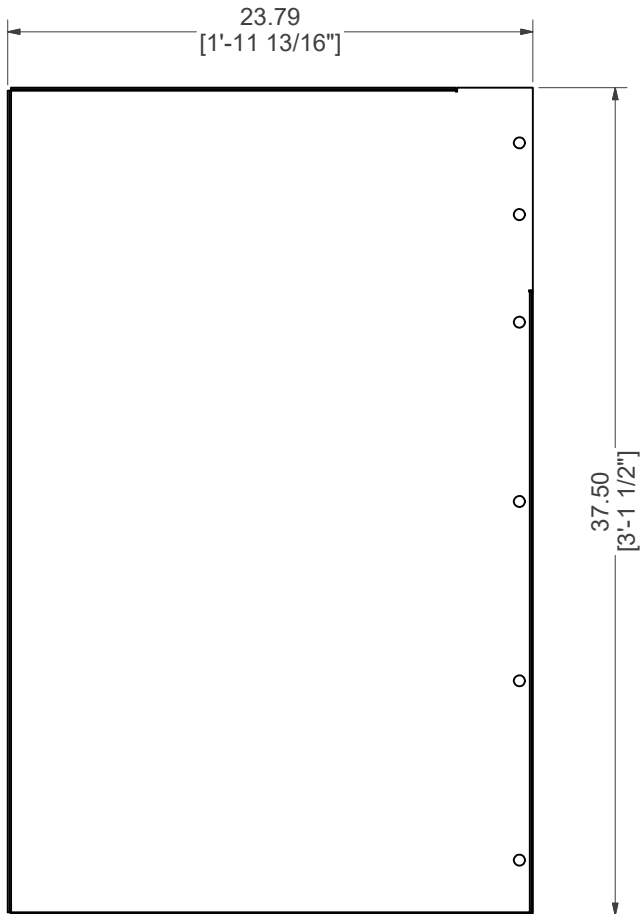
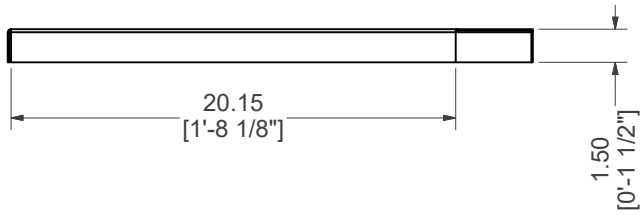

# BRACE, TOP RISER SUPPORT

<b>PART #:</b> ESC-18336-TRB  	<b>WEIGHT:</b> 21.12 lbmass	<b>MACHINE TIME:</b> N/A	<b>FILE/DIRECTORY:</b> C:\Vault\FTW\Design\CUSTOM STEPS\ESC-18000-18999\ESC-18336.idw
	<b>TOLERANCES EXCEPT AS NOTED</b> 0/0 0.0 0.00 0.000 0' ±1/8 ±0.25 ±0.0625 ±0.03125 ±1/2'	<b>MATERIAL:</b> 14 GA. GALVANIZED	<b>DATE:</b> 3/14/2024
<b>DRAWN BY:</b> SA	<b>SHEET:</b> 26 OF 35		

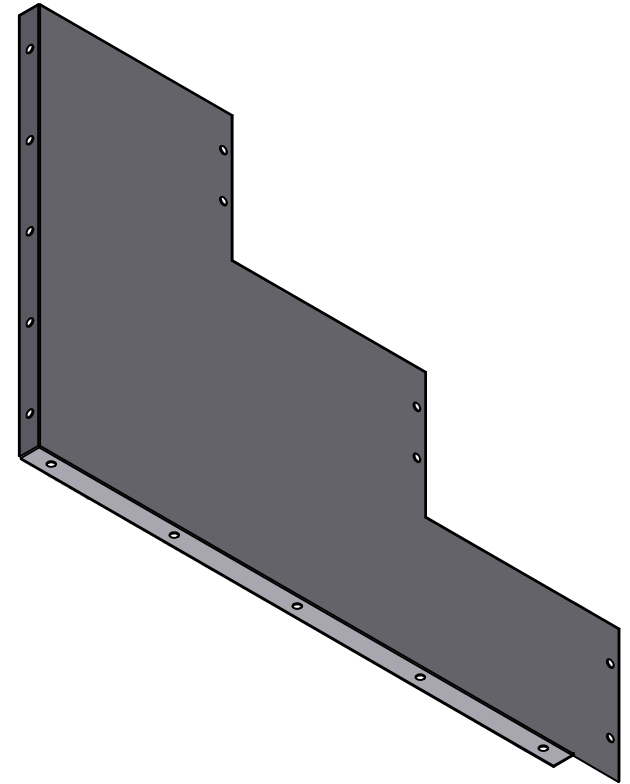
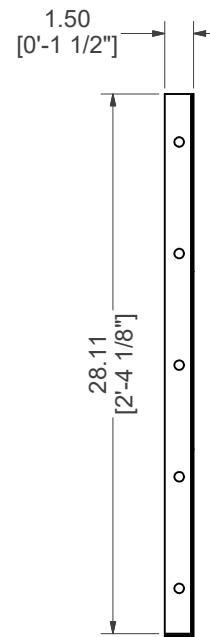
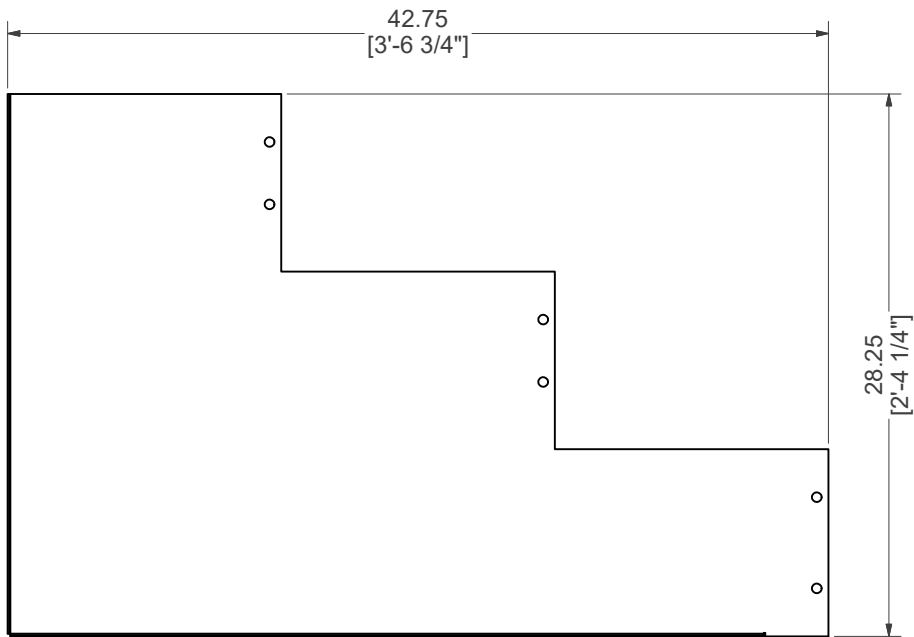
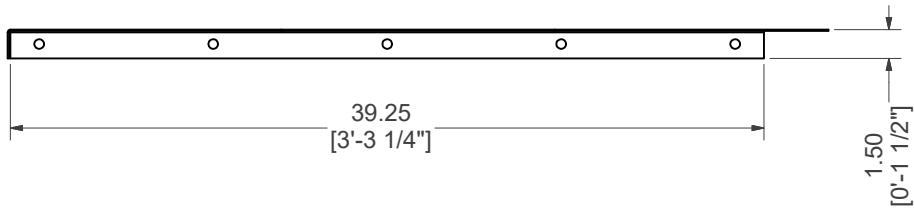

# BRACE, 3-RISER SUPPORT

<b>PART #:</b> ESC-18336-B	<b>WEIGHT:</b> 18.33 lbmass	<b>MACHINE TIME:</b> N/A	<b>FILE/DIRECTORY:</b> C:\Vault\FTW\Design\CUSTOM STEPS\ESC-18000-18999\ESC-18336.idw	
	<b>TOLERANCES EXCEPT AS NOTED</b> 0/0 0.0 0.00 0.000 0' ±1/8 ±0.25 ±0.0625 ±0.03125 ±1/2'	<b>MATERIAL:</b> 14 GA. GALVANIZED	<b>DATE :</b> 3/14/2024	<b>NOTES:</b>
		<b>DRAWN BY:</b> SA	<b>SHEET :</b> 27 OF 35	

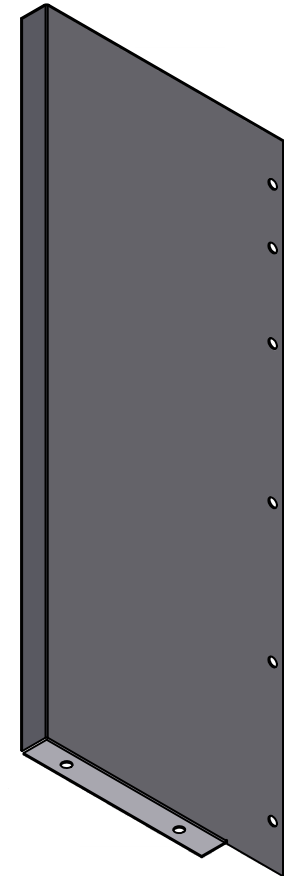
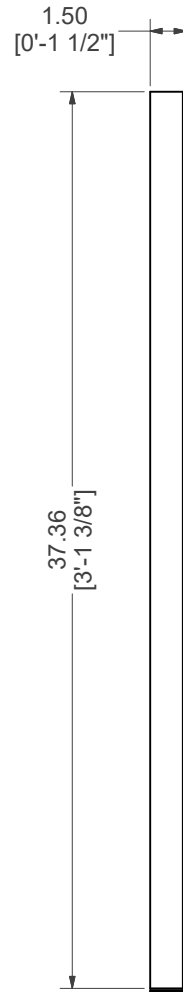
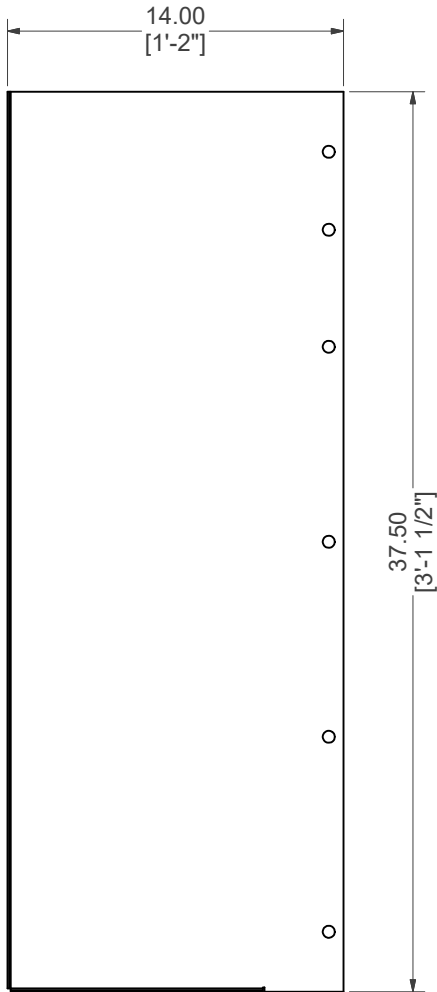
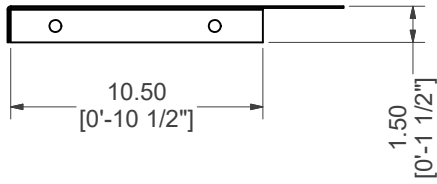

# BRACE, TOP RISER SUPPORT

<b>PART #:</b> ESC-18336-TRS	<b>WEIGHT:</b> 11.98 lbmass	<b>MACHINE TIME:</b> N/A	<b>FILE/DIRECTORY:</b> C:\Vault\FTW\Design\CUSTOM STEPS\ESC-18000-18999\ESC-18336.idw	
	TOLERANCES EXCEPT AS NOTED 0/0 0.0 0.00 0.000 0' ±1/8 ±0.25 ±0.0625 ±0.03125 ±1/2'	<b>MATERIAL:</b> 14 GA. GALVANIZED	<b>DATE :</b> 3/14/2024	<b>NOTES:</b>
		<b>DRAWN BY:</b> SA	<b>SHEET :</b> 28 OF 35	

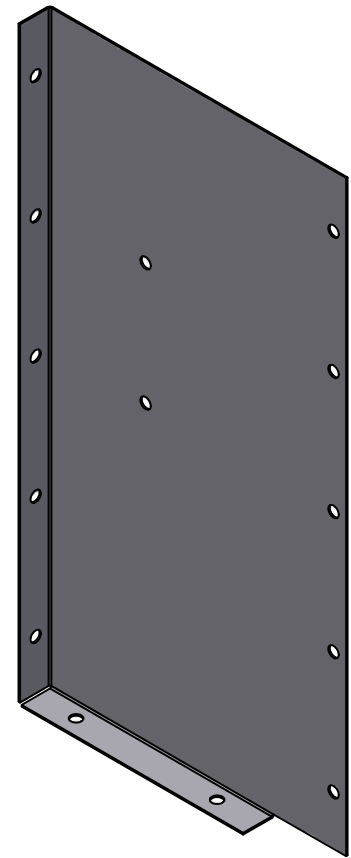
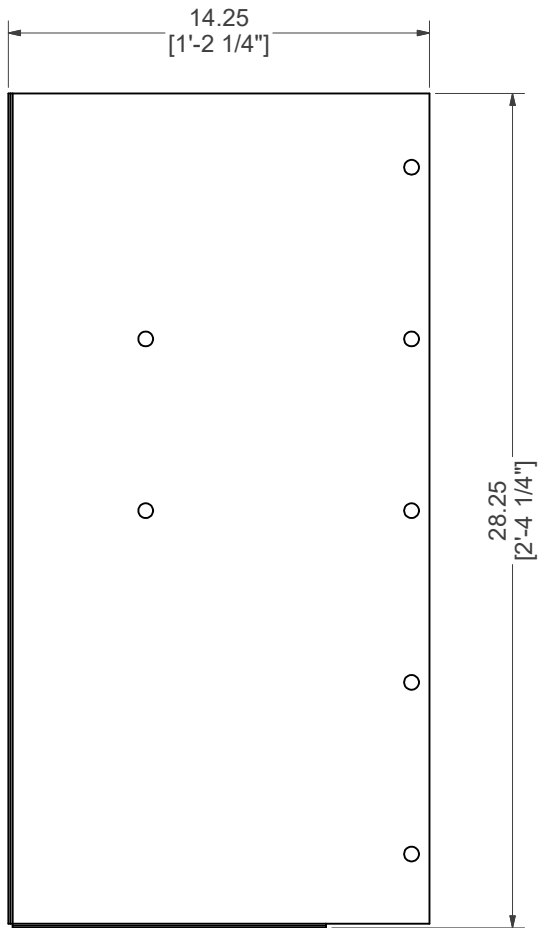
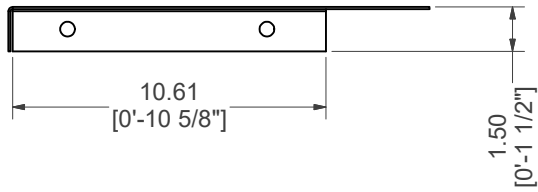

# BRACE, SUNLEDGE RISER SUPPORT

<b>PART #:</b> ESC-18336-SRS  	<b>WEIGHT:</b> 9.20 lbmass	<b>MACHINE TIME:</b> N/A	<b>FILE/DIRECTORY:</b> C:\Vault\FTW\Design\CUSTOM STEPS\ESC-18000-18999\ESC-18336.idw	
	<b>MATERIAL:</b> 14 GA. GALVANIZED		<b>DATE :</b> 3/14/2024	<b>NOTES:</b>
<b>TOLERANCES EXCEPT AS NOTED</b> 0/0 0.0 0.00 0.000 0' ±1/8 ±0.25 ±0.0625 ±0.03125 ±1/2'		<b>DRAWN BY:</b> SA	<b>SHEET :</b> 29 OF 35	

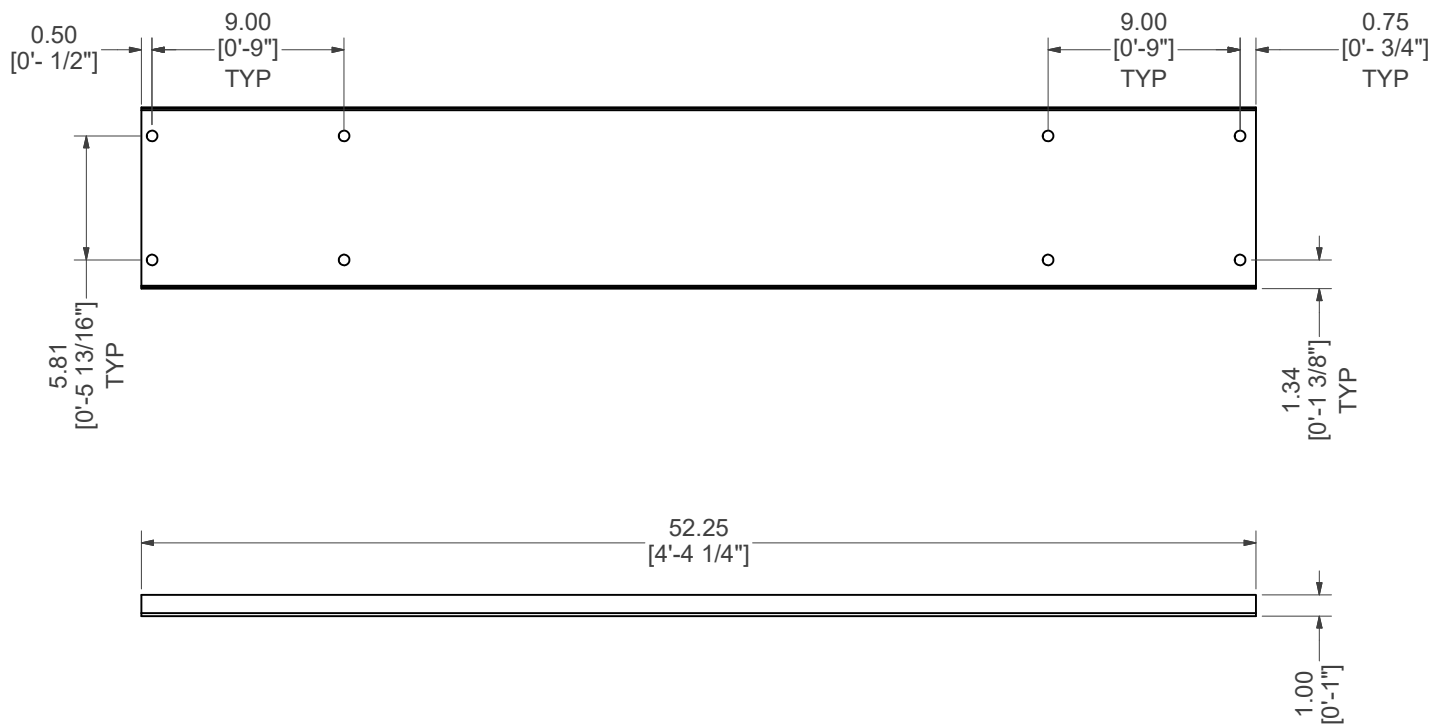
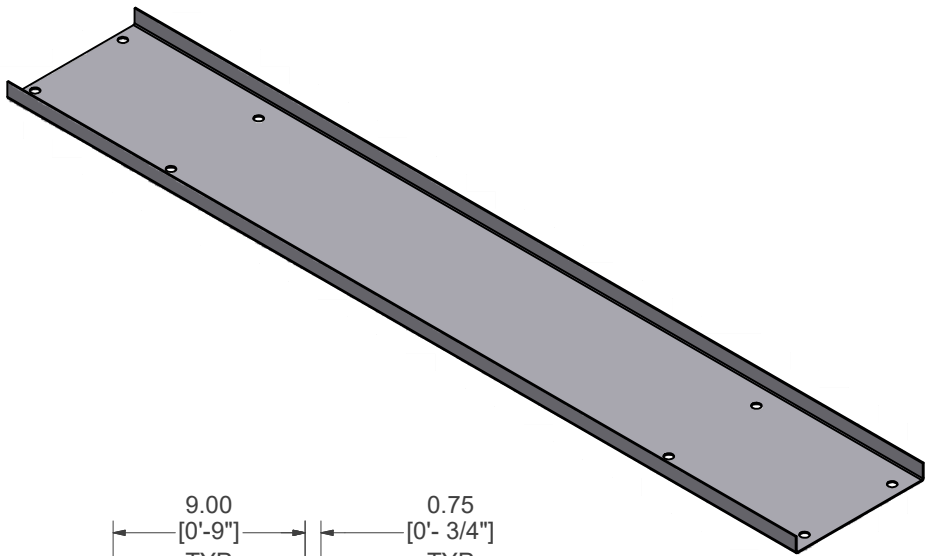

## BRACE, CENTER SUPPORT

<b>PART #:</b> ESC-9625-CB	<b>WEIGHT:</b> 10.87 lbmass	<b>MACHINE TIME:</b> N/A	<b>FILE/DIRECTORY:</b> C:\Vault\FTW\Design\CUSTOM STEPS\ESC-18000-18999\ESC-18336.idw
	<b>TOLERANCES EXCEPT AS NOTED</b> 0/0 0.0 0.00 0.000 0' ±1/8 ±0.25 ±0.0625 ±0.03125 ±1/2'	<b>MATERIAL:</b> 14 GA. GALVANIZED  <b>DRAWN BY:</b> SA	<b>DATE:</b> 3/14/2024  <b>SHEET:</b> 30 OF 35  <b>NOTES:</b>

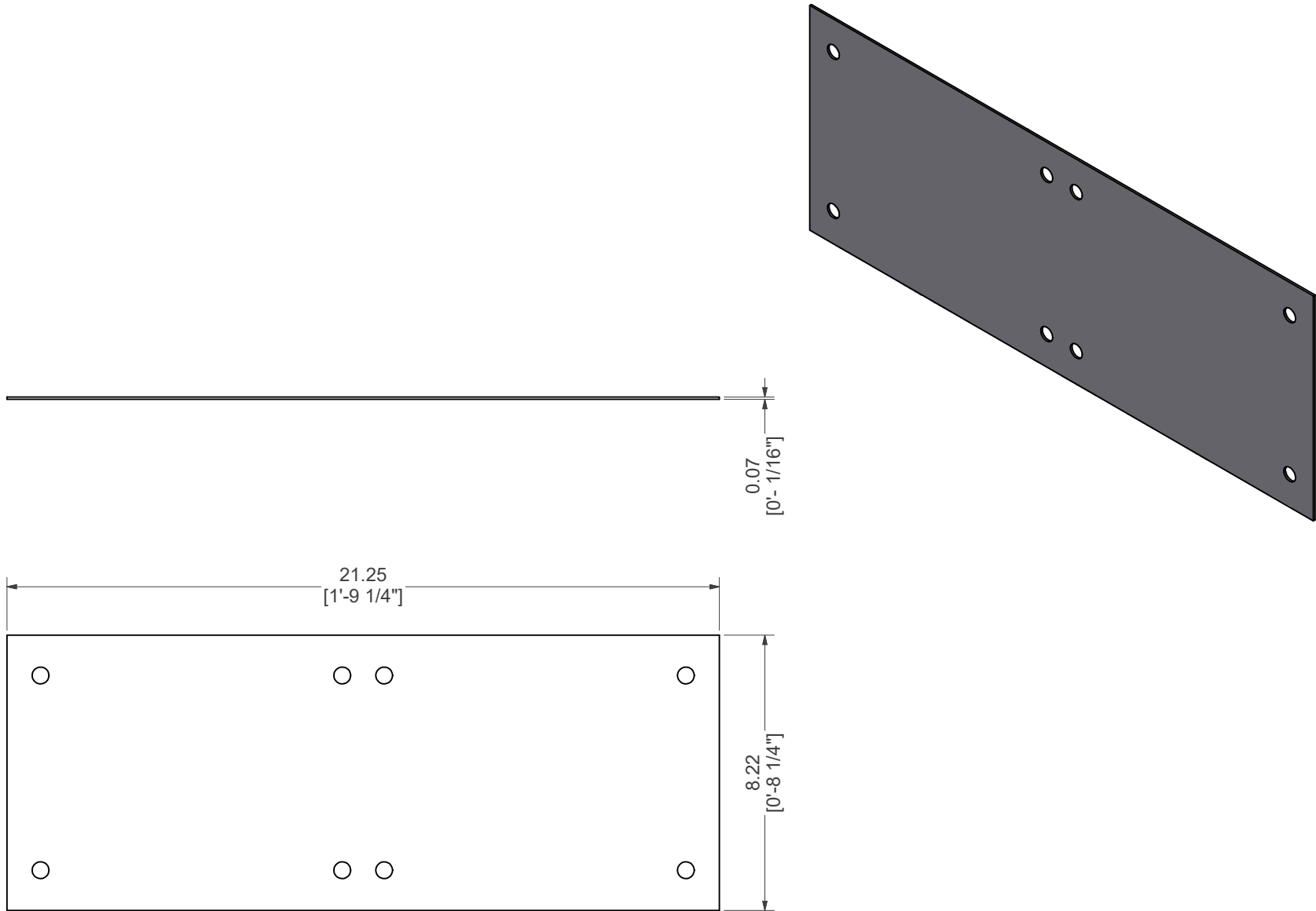

# BRACE, FLAT PLATE

<b>PART #:</b> ESC-9625-PT	<b>WEIGHT:</b> 3.52 lbmass	<b>MACHINE TIME:</b> N/A	<b>FILE/DIRECTORY:</b> C:\Vault\FTW\Design\CUSTOM STEPS\ESC-18000-18999\ESC-18336.idw	
	TOLERANCES EXCEPT AS NOTED 0/0 0.0 0.00 0.000 0' ±1/8 ±0.25 ±0.0625 ±0.03125 ±1/2'	<b>MATERIAL:</b> 14 GA. GALVANIZED	<b>DATE :</b> 3/14/2024	<b>NOTES:</b>
		<b>DRAWN BY:</b> SA	<b>SHEET :</b> 31 OF 35	

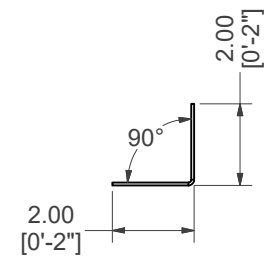
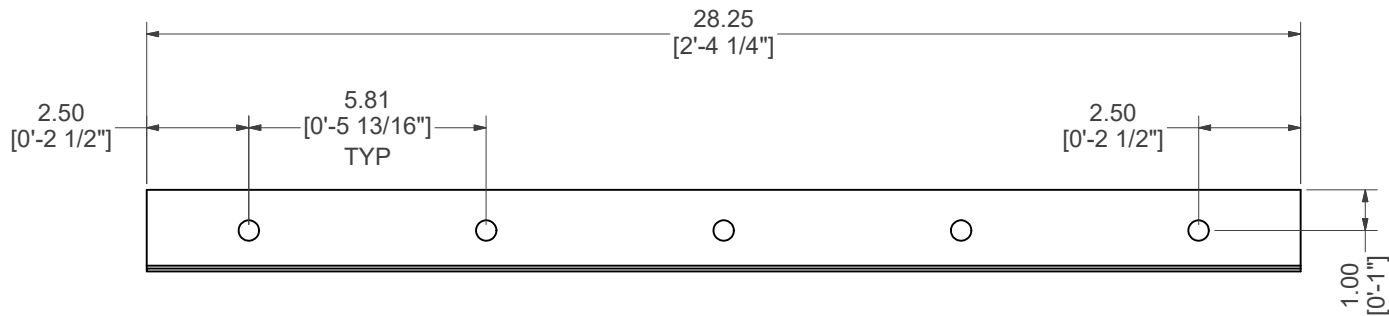
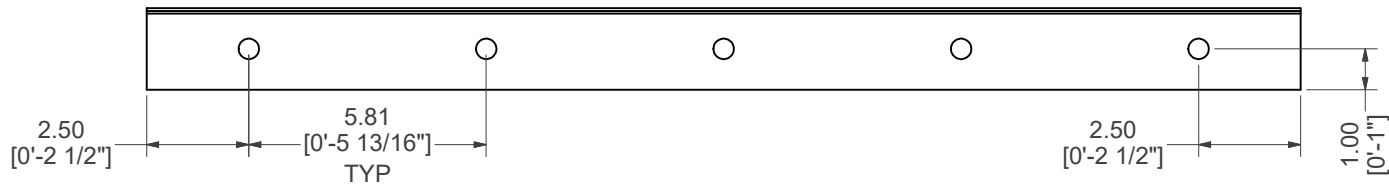
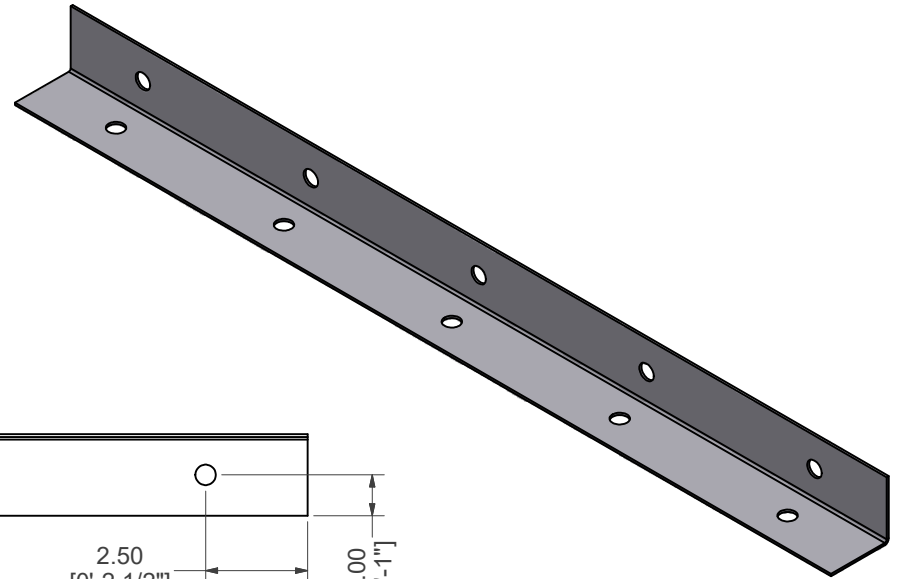

# BRACE, 90° L BRACKET

<b>PART #:</b> ESC-9625-BB	<b>WEIGHT:</b> 2.19 lbmass	<b>MACHINE TIME:</b> N/A	<b>FILE/DIRECTORY:</b> C:\Vault\FTW\Design\CUSTOM STEPS\ESC-18000-18999\ESC-18336.idw
	TOLERANCES EXCEPT AS NOTED 0/0 0.0 0.00 0.000 0' ±1/8 ±0.25 ±0.0625 ±0.03125 ±1/2'	<b>MATERIAL:</b> 14 GA. GALVANIZED  <b>DRAWN BY:</b> SA	<b>DATE:</b> 3/14/2024  <b>SHEET:</b> 32 OF 35  <b>NOTES:</b>



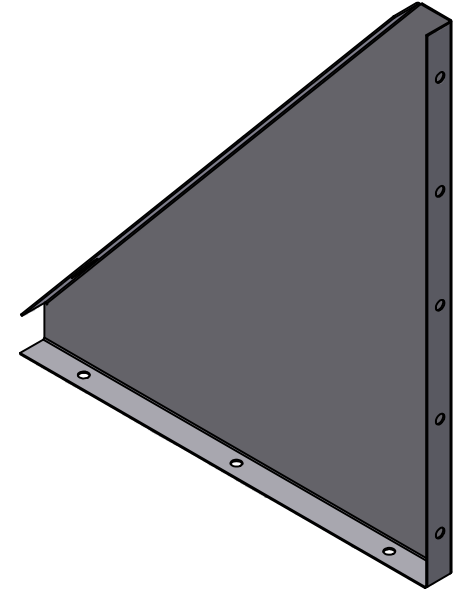
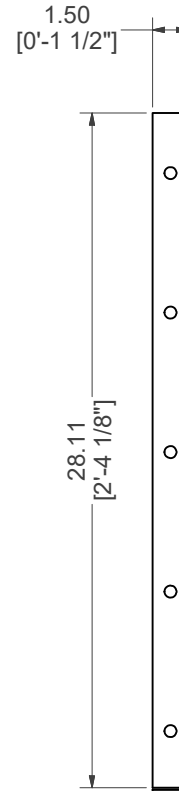
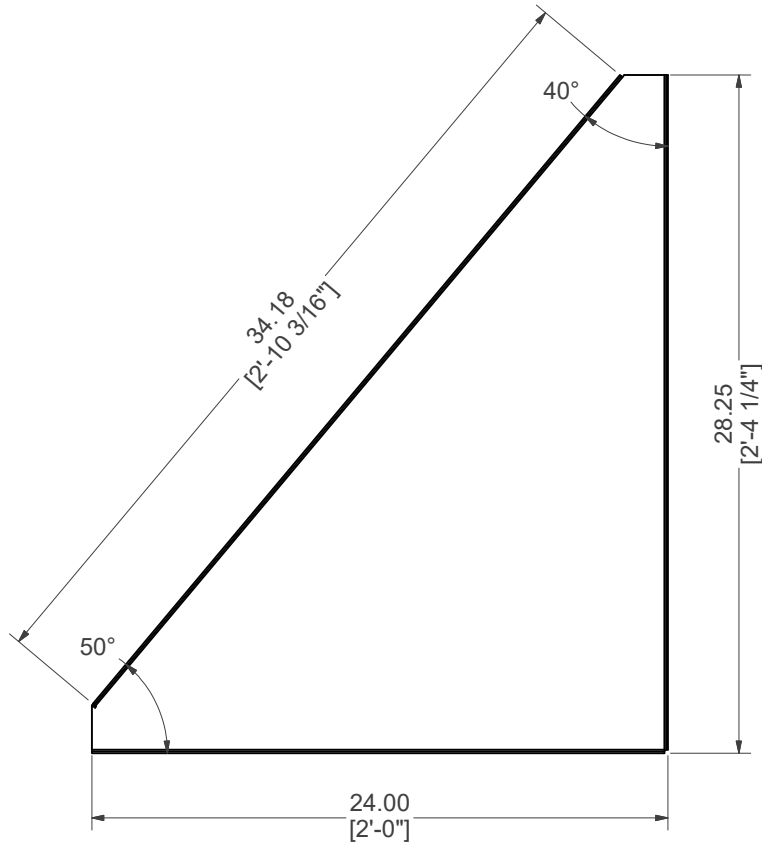
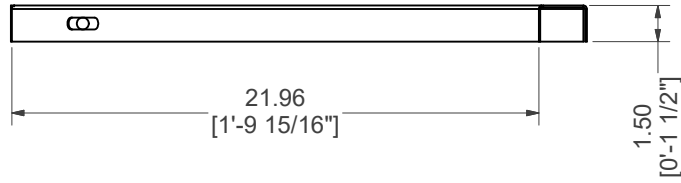

# BRACE, SUNLEDGE RISER ANGLE SUPPORT

<b>PART #:</b> ESC-9545-BUB  	<b>WEIGHT:</b> 10.28 lbmass	<b>MACHINE TIME:</b> N/A	<b>FILE/DIRECTORY:</b> C:\Vault\FTW\Design\CUSTOM STEPS\ESC-18000-18999\ESC-18336.idw
	TOLERANCES EXCEPT AS NOTED 0/0 0.0 0.00 0.000 0' ±1/8 ±0.25 ±0.0625 ±0.03125 ±1/2"	<b>MATERIAL:</b> 14 GA. GALVANIZED  <b>DRAWN BY:</b> SA	<b>DATE :</b> 3/14/2024  <b>SHEET :</b> 33 OF 35

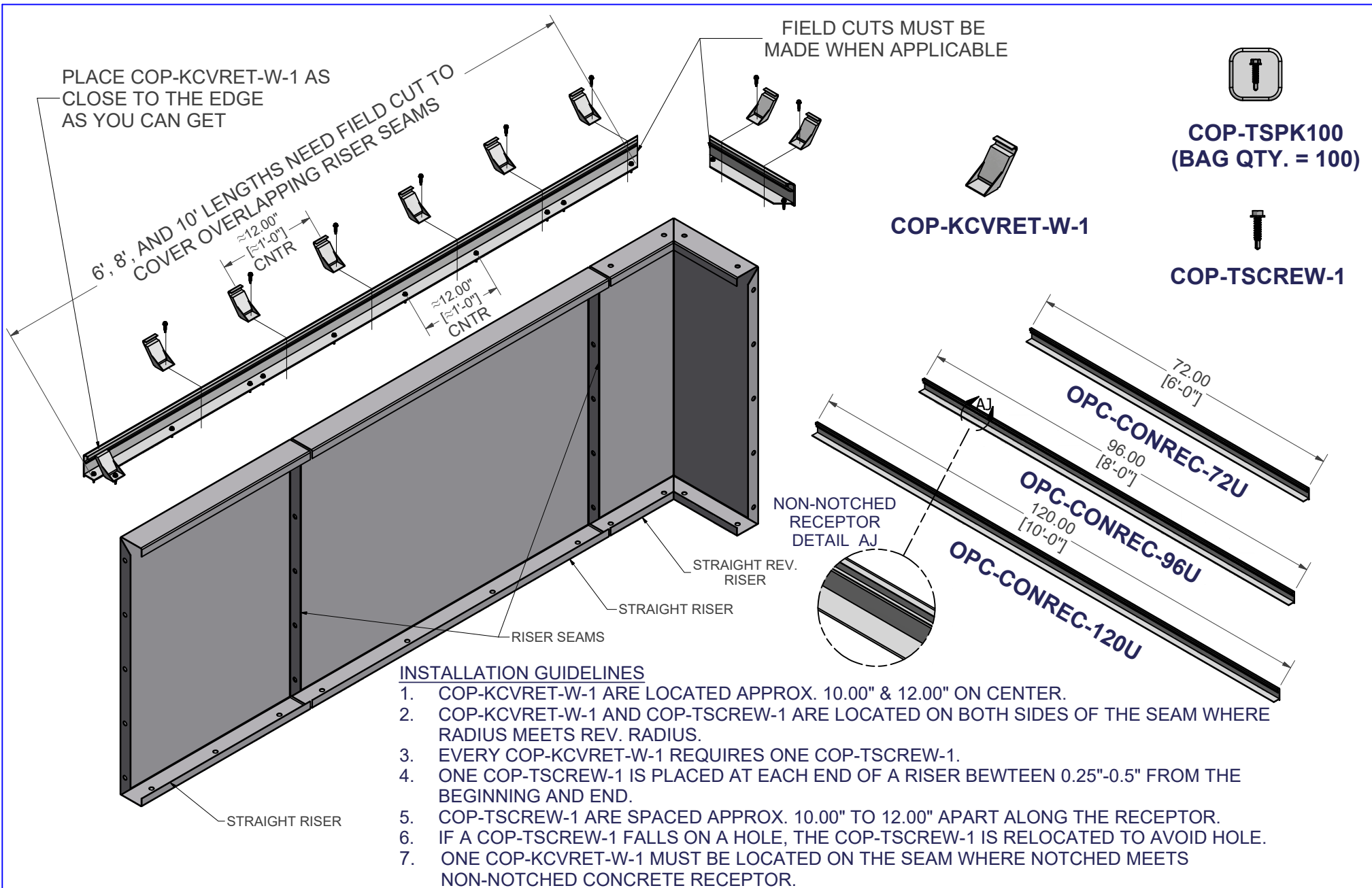

# NON-NOTCHED CONCRETE RECEPTOR FIELD INSTALLATION

<b>PART #</b> <b>STRAIGHT CONCRETE RECEPTOR</b>	<b>WEIGHT:</b> 77.51 lbmass	<b>MACHINE TIME:</b> N/A	<b>FILE/DIRECTORY:</b> C:\Vault\FTW\Design\CUSTOM STEPS\ESC-18000-18999\ESC-18336.idw	
	<b>TOLERANCES EXCEPT AS NOTED</b> 0/0 0.0 0.00 0.000 0' ±1/8 ±0.25 ±0.0625 ±0.03125 ±1/2"	<b>MATERIAL:</b>	<b>DATE:</b> 3/14/2024	<b>NOTES:</b>
	<b>DRAWN BY:</b> SA	<b>SHEET:</b> 34 OF 35		

PLACE COP-KCVRET-W-1 AT SEAMS WHERE STRAIGHT MEETS A RADIUS/REV. RADIUS.

PLACE COP-TSCREW-1 ON BOTH SIDES OF THE SEAMS.

PLACE COP-KCVRET-W-1 AS CLOSE TO THE END EDGE AS YOU CAN GET.

FIELD CUTS MUST BE MADE WHEN APPLICABLE



**COP-TSPK100**  
(BAG QTY. = 100)



**COP-TSCREW-1**

**COP-KCVRET-W-1**

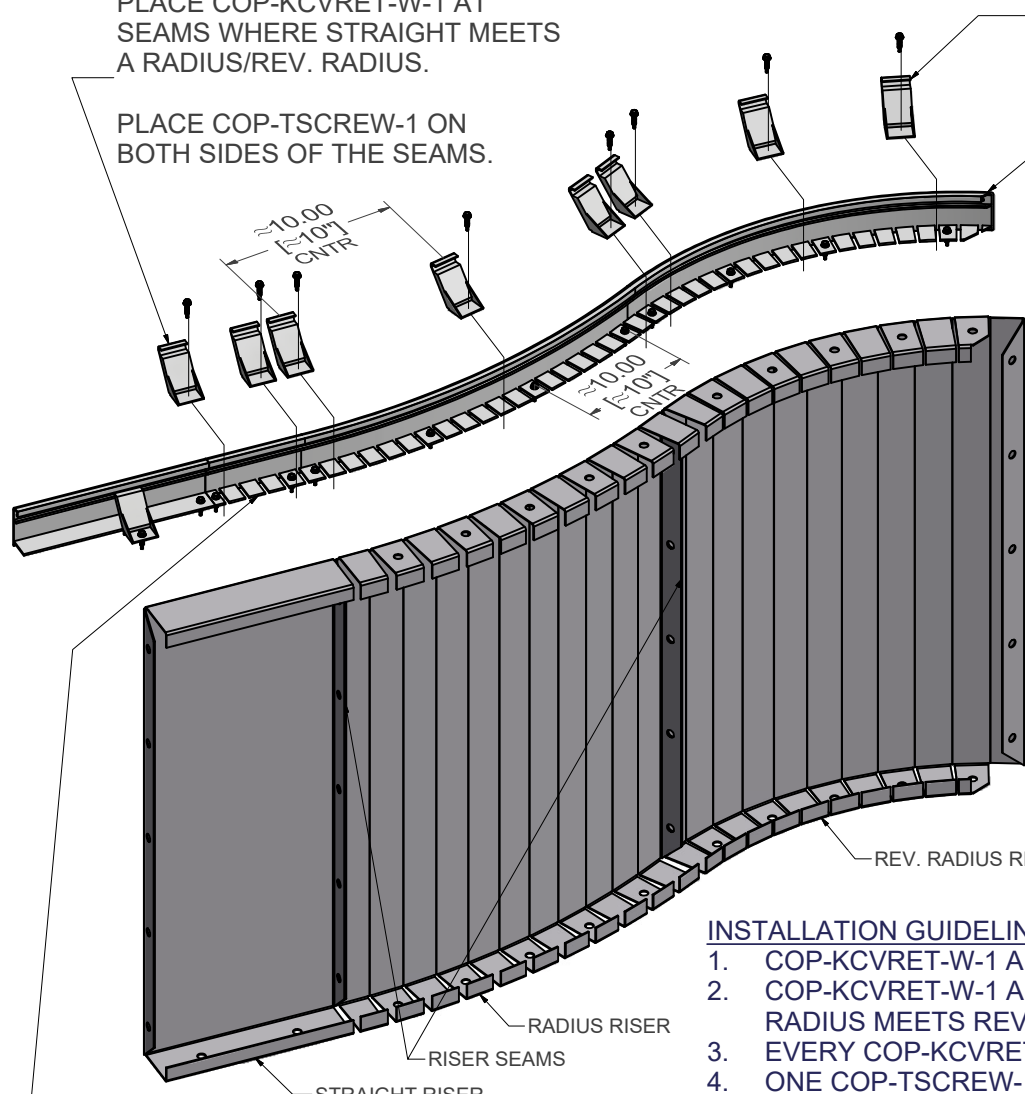

NOTCHED RECEPTOR DETAIL AK

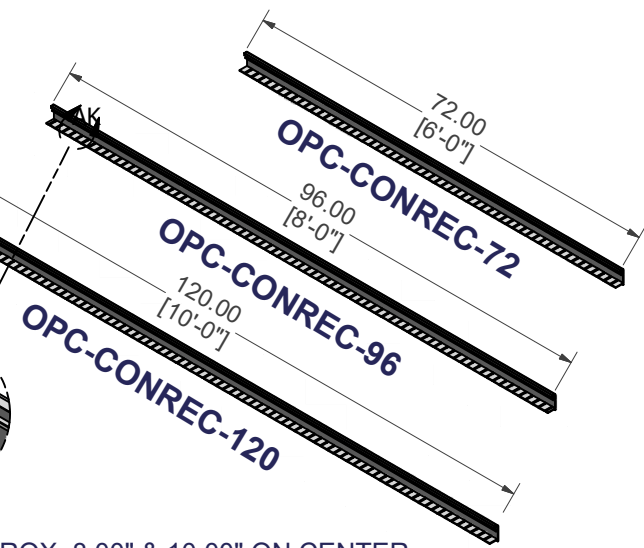
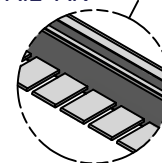

ALLOW AN APPROX. OF 6.00" OF OVERLAP GOING FROM RADIUS/ REV. RADIUS TO A STRAIGHT RISER.

**INSTALLATION GUIDELINES**

1. COP-KCVRET-W-1 ARE LOCATED APPROX. 8.00" & 10.00" ON CENTER.
2. COP-KCVRET-W-1 AND COP-TSCREW-1 ARE LOCATED ON BOTH SIDES OF THE SEAM WHERE RADIUS MEETS REV. RADIUS.
3. EVERY COP-KCVRET-W-1 REQUIRES ONE COP-TSCREW-1.
4. ONE COP-TSCREW-1 IS PLACED AT EACH END OF A RISER BEWTEEN 0.25"-0.5" FROM THE BEGINNING AND END.
5. COP-TSCREW-1 ARE SPACED APPROX. 8.00" TO 10.00" APART ALONG THE RECEPTOR.
6. IF A COP-TSCREW-1 FALLS ON A HOLE, THE COP-TSCREW-1 IS RELOCATED TO AVOID HOLE.
7. ONE COP-KCVRET-W-1 MUST BE LOCATED ON THE SEAM WHERE NOTCHED MEETS NON-NOTCHED CONCRETE RECEPTOR.

# NOTCHED CONCRETE RECEPTOR FIELD INSTALLATION

**REV-RADIUS CONCRETE RECEPTOR**

**WEIGHT:**  
52.49 lbmass

**MACHINE TIME:**  
N/A

**FILE/DIRECTORY:**

C:\Vault\FTW\Design\CUSTOM STEPS\ESC-18000-18999\ESC-18336.idw



TOLERANCES EXCEPT AS NOTED  
0/0 0.0 0.00 0.000 0'  
±1/8 ±0.25 ±0.0625 ±0.03125 ±1/2"

**MATERIAL:**

**DATE:** 3/14/2024

**NOTES:**

**DRAWN BY:** SA

**SHEET:** 35 OF 35