

REVISION HISTORY					
REV	DESCRIPTION	DATE	ECO	BY	
A	WORKING	10/24/2013		LNELSON	
B	ADDED CUSTOMER NUMBER	08/22/14		RCOLBOCH	

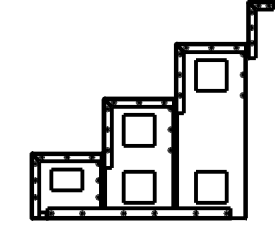
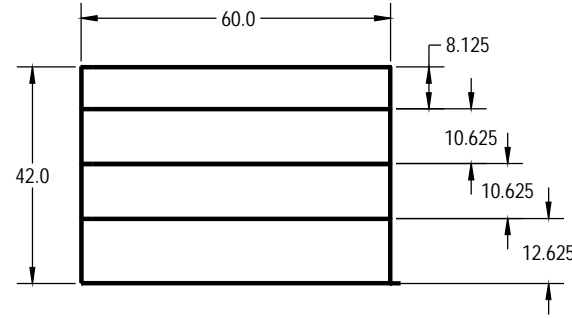
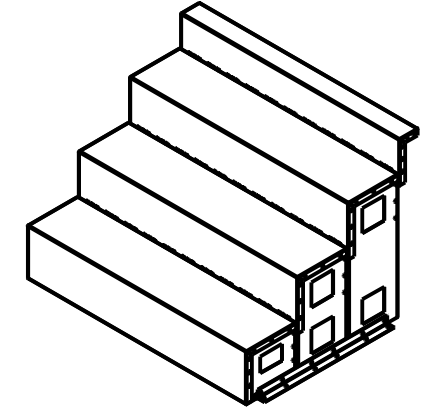
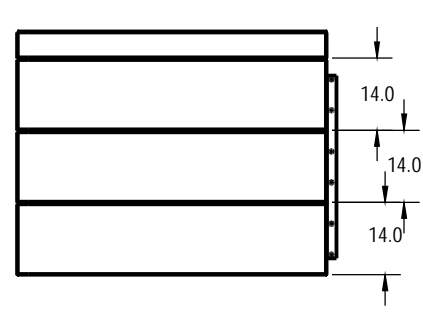
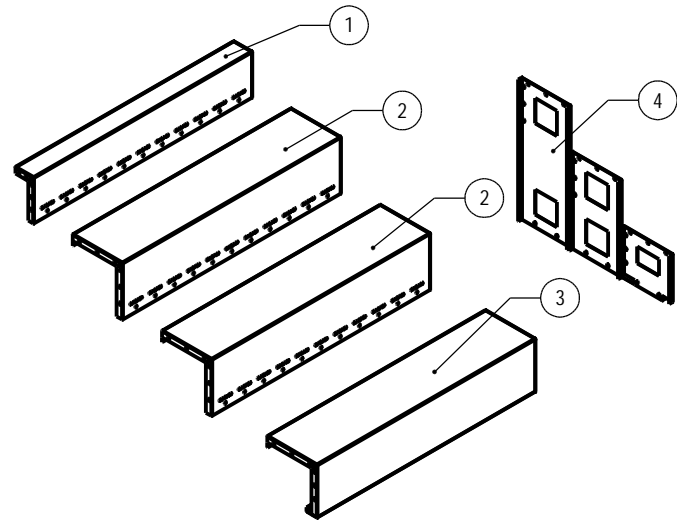

- NOTES:**
- THESE ARE FINISHED DIMENSIONS READY FOR THE LINER.
 - DIMENSIONS ARE FROM INSIDE POOL PANELS.
 - THE RISER WATER LEVER SHOULD BE TO THE MIDDLE OF THE SKIMMER OPENING(S).
- EXCAVATION NOTES:**
- ROUGH EXCAVATION SHOULD BE 2" DEEPER IN EACH INSTANCE.
 - SOL TO HAVE MINIMUM BEARING CAPACITY OF 1500 PSF.
 - LOCATE TOP OF POOL AT LEAST 4" ABOVE THE SURROUNDING LAND ELEVATION.
 - SEE "OVER DIG DETAIL" FOR EXCAVATION AROUND POOL.
 - FILL VOIDS UNDER BASE OF PANELS AND TAMP WELL.
 - BACK FILL WITH NON-EXPANSIVE MATERIAL.
 - ANSI/APSP/ICC-5 FOR RESIDENTIAL POOLS, 2003-2007 BOCA CODE SECTION 421.

IMPORTANT NOTES:

11. THIS DOCUMENT IS FOR ILLUSTRATIVE PURPOSES ONLY. THE DEALER OR CONTRACTOR WHO SELLS OR INSTALLS YOUR POOL IS AN INDEPENDENT CONTRACTOR AND IS NOT AN AGENT OF THE MANUFACTURER. THE CONSTRUCTION METHODS ILLUSTRATED HERE ARE SUGGESTIONS AND APPLY ONLY TO NORMAL GROUND CONDITIONS. THERE MAY BE ADDITIONAL PRECAUTIONS AND/OR METHODS OF CONSTRUCTION. PROPER INSTALLATION IS THE RESPONSIBILITY OF THE DEALER/BUILDER/CONTRACTOR.

ITEM	FILE NAME	DESCRIPTION	CUSTOMER DRAWING #	VENDOR PART #	QTY.	VENDOR NAME	MATERIAL
1	00004213	TREAD, STEP, 3 TREAD "A" 5' LONG			1	SAMSON STEEL	G-235.14 GA
2	00004214	TREAD, STEP, 3 TREAD "B" 5' LONG			2	SAMSON STEEL	G-235.14 GA
3	00004215	TREAD, STEP, 3 TREAD "C" 5' LONG			1	SAMSON STEEL	G-235.14 GA
4	00004115	SUPPORT, CENTER, 3 TREAD STEP, ASSEMBLY			1		
5	00000305	HBOLT 0.3750-16x14-1-N		H03162	94	HYDRA POOLS	AISI 1020
6	00000306	HWNT 0.3750-16x14-1-N		H03163	94	HYDRA POOLS	AISI 1020

UNLESS OTHERWISE SPECIFIED DIMENSIONS ARE IN INCHES TOLERANCES: DECIMALS: X + 0.1 XX + 0.01 XXX + 0.005 XXXX + 0.0005 ANGULAR: X + 0.5 THIRD ANGLE PROJECTION	DESIGNED BY: LNELSON	CREATION DATE: 09/27/13	SAMSON STEEL STEP, 3 TREAD, 5' LONG, SUB ASSEMBLY PART NUMBER: HSS3M5
	RETAILED BY: RCOLBOCH	DATE TAKEN DATE: 10/24/2013	
	LAST REVISED BY: RCOLBOCH	LAST REVISED DATE: 08/22/14	
	MATERIAL:		

SCALE: 1:24	SHEET: 1 OF 1	SIZE: B
----------------	------------------	-------------------