

REVISION HISTORY					
REV	DESCRIPTION	DATE	ECO	BY	
A	WORKING	10/24/2013		L NELSON	
B	ADDED CUSTOMER NUMBER	04/25/14		RCOLBOCH	

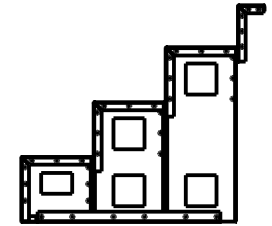
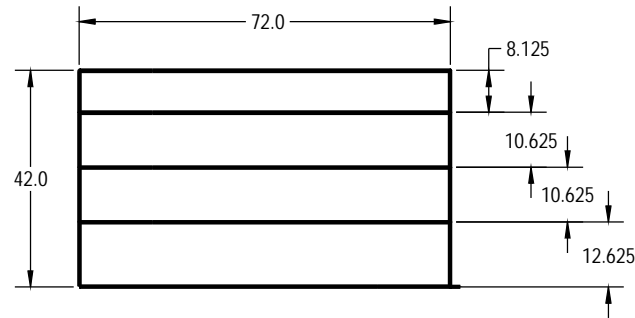
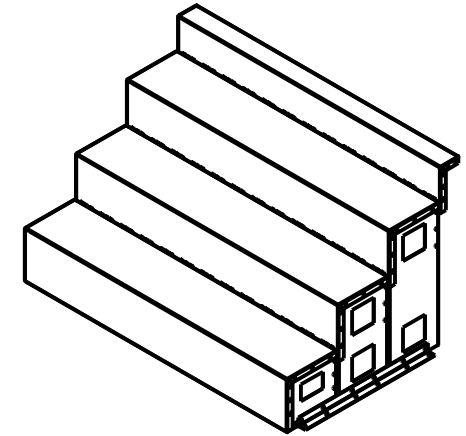
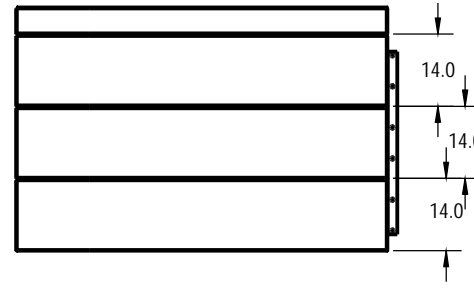
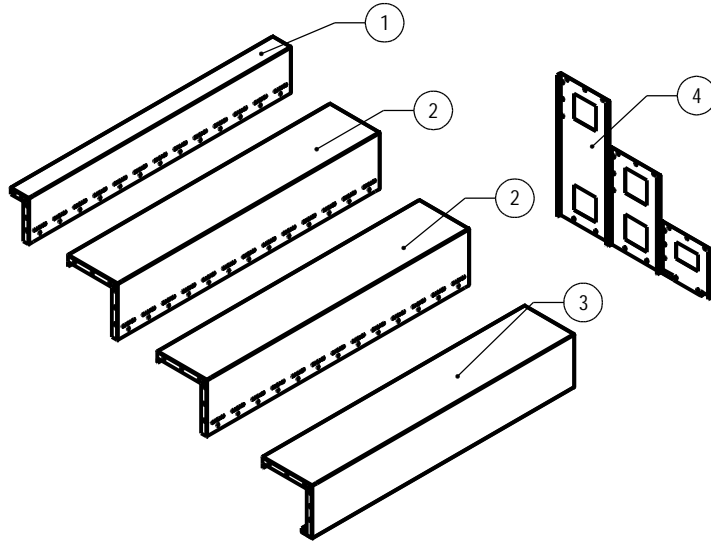

NOTES:

1. THESE ARE FINISHED DIMENSIONS READY FOR THE LINER.
 2. DIMENSIONS ARE FROM INSIDE POOL PANELS.
 3. THE RIGAL WATER LEVER SHOULD BE TO THE MIDDLE OF THE SKIMMER OPENING(S).
- EXCAVATION NOTES:**
4. ROUGH EXCAVATION SHOULD BE 2" DEEPER IN EACH INSTANCE.
 5. SOIL TO HAVE MINIMUM BEARING CAPACITY OF 1500 PSF.
 6. LOCATE TOP OF POOL AT LEAST 4" ABOVE THE SURROUNDING LAND ELEVATION.
 7. SEE "OVER DIG DETAIL" FOR EXCAVATION AROUND POOL.
 8. FILL VOIDS UNDER BASE OF PANELS AND TAMP WELL.
 9. BACK FILL WITH NON-EXPANSIVE MATERIAL.
 10. ANSII/APSP/ICC-5 FOR RESIDENTIAL POOLS, 2003-2007 BOCA CODE SECTION 421.

- IMPORTANT NOTES:**
11. THIS DOCUMENT IS FOR ILLUSTRATIVE PURPOSES ONLY. THE DEALER OR CONTRACTOR WHO SELLS OR INSTALLS YOUR POOL IS AN INDEPENDENT CONTRACTOR AND IS NOT AN AGENT OF THE MANUFACTURER. THE CONSTRUCTION METHODS ILLUSTRATED HERE ARE SUGGESTIONS AND APPLY ONLY TO NORMAL GROUND CONDITIONS. THERE MAY BE ADDITIONAL PRECAUTIONS AND/OR METHODS OF CONSTRUCTION. PROPER INSTALLATION IS THE RESPONSIBILITY OF THE DEALER/BUILDER/CONTRACTOR.

ITEM	FILE NAME	DESCRIPTION	CUSTOMER DRAWING #	VENDOR PART #	QTY.	VENDOR NAME	MATERIAL
1	00004219	TREAD, STEP, 3 TREAD "A" 6' LONG			1	SAMSON STEEL	G-235.14 GA
2	00004220	TREAD, STEP, 3 TREAD "B" 6' LONG			2	SAMSON STEEL	G-235.14 GA
3	00004221	TREAD, STEP, 3 TREAD "C" 6' LONG			1	SAMSON STEEL	G-235.14 GA
4	00004115	SUPPORT, CENTER, 3 TREAD STEP, ASSEMBLY			1		
5	00000305	HBOLT 0.3750-16x1.1-N		H03162	94	HYDRA POOLS	AISI 1020
6	00000306	HWNT 0.3750-16x1.1-N		H03163	94	HYDRA POOLS	AISI 1020

WEIGHT: 192.5 lbs. VOLUME: Inch³ COLOR: HEAT TREAT: FINISH: TEXTURE:	UNLESS OTHERWISE SPECIFIED DIMENSIONS ARE IN INCHES TOLERANCES DECIMALS: X + 0.1 XX + 0.01 XXX + 0.005 XXXX + 0.0005 ANGULAR: X + 0.5 THIRD ANGLE PROJECTION	DESIGNED BY: L NELSON ORIGIN DATE: 09/27/13	SAMSON STEEL STEP, 3 TREAD, 6' LONG, SUB ASSEMBLY
		RETAILED BY: RCOLBOCH DETAILED DATE: 10/24/2013	
PART NUMBER: HSS3M6		TITLE: STEP, 3 TREAD, 6' LONG, SUB ASSEMBLY	SCALE: 1/2" = 1'-0" SHEET: 1 OF 1