

INSTALLATION OPERATION & SERVICE MANUAL

SAFETY

Read and follow the safety instructions listed below and other basic safety precautions before installation or operation of this transformer and other associated equipment.

These safety transformers are specifically designed to supply 12 VAC to Landscape, fountain, swimming pool and spa luminaires. Suitable for submersible luminaires.

⚠ WARNING Risk of Fire or Electrical Shock

- If installation involves running wire through a building structure, special wiring methods are needed.
- Do Not submerge transformer.
- Do Not exceed the maximum ratings of individual components, wiring devices, and current carrying capacity of conductors.
- Select power source by combining bulb wattage.

Installation must comply with provisions of the National Electrical Code, ANSI/NFPA 70, including those in Article 680 - Swimming Pools, Spas, Fountains and Water Features.

CAUTION: for use only on a branch circuit protected by a CLASS A type ground fault circuit interrupter.

Canada Only:

For pre-installed plugged versions LVX50P & LVX100P, please ensure transformer is connected to a **CLASS A** type GFCI protected outlet. **Not for use with an extension cord.**

REMOVING KNOCKOUT

The LVX transformer supports the use of 1/2" and 3/4" conduit connections on the under side of the unit. When using 3/4" conduit connections, remove break away as shown.

- 1.** Remove port caps from the required ports

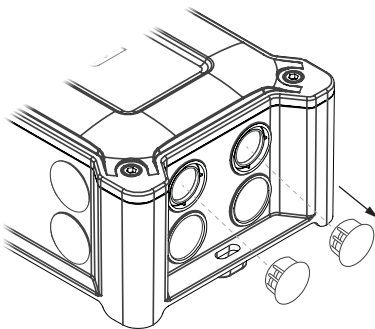

- 2.** Using a pair of side cutters cut the internal ring supports

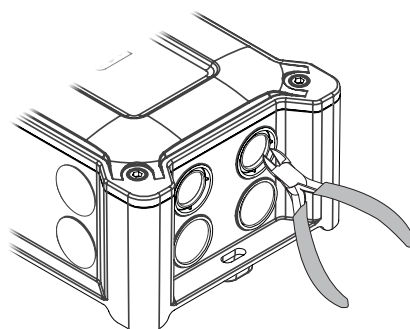

- 3.** Remove the internal ring from the conduit port.

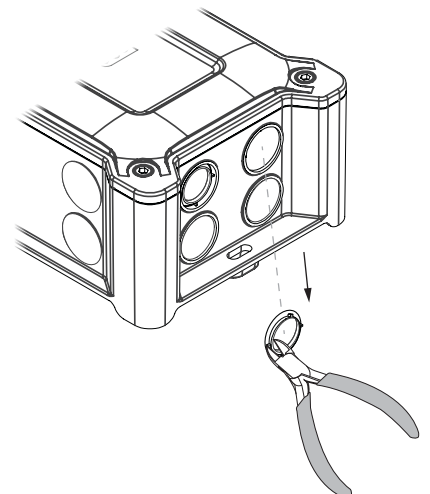

PRODUCT INSTALLATION

INSTALLATION

Installation must comply with provisions of the National Electrical Code, ANSI/NFPA 70, including those in Article 680 - Swimming Pools, Spas, Fountains and Water Features.

- For field wiring information, please refer to the instructions attached to inside of front cover.
- Make sure that all unused taps (leads) are separately insulated.
- The voltage at lamp terminals after installation should be 12 ± 1.0 VAC.

Landscape Lighting:

The low-voltage wire or cable extending from the power-unit output circuit to, and between, the individual luminaires and fittings is intended to be certified SPT-3, SPT-2W, a junior or hard service cord (SJTW, STW, or similar) underground low-energy circuit cable, or other wire or cable rated as sunlight resistant, suitable for wet locations, and intended for direct burial.

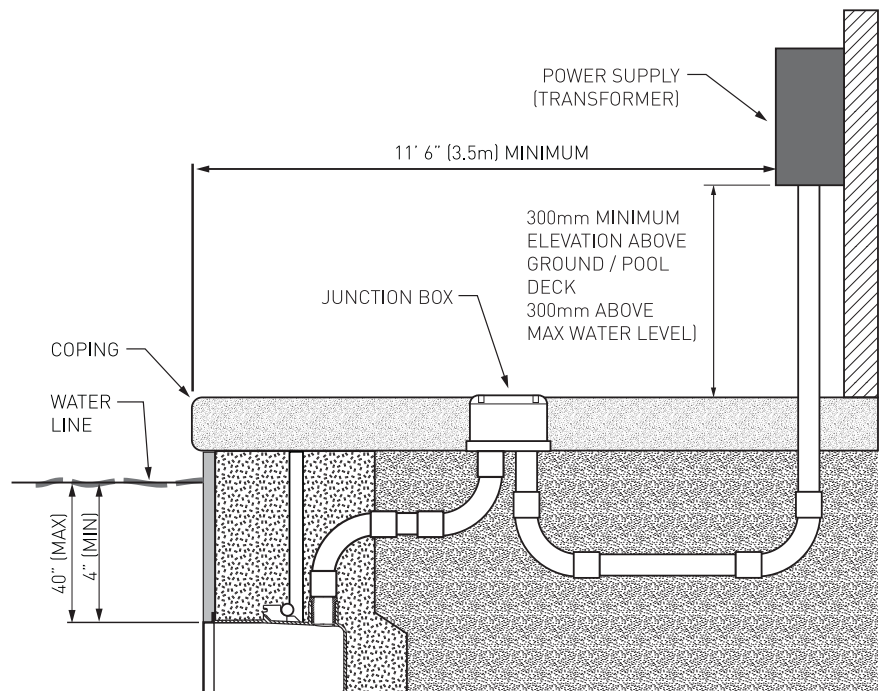

Power supplies are for outdoor use only.

GENERAL INFORMATION

SPECIFICATIONS

Enclosure Size: H27cm x W15cm x D10cm

Mounting: (2) positions (top and bottom.)

Enclosure Type: UL Listed Polycarbonate (black)

Primary Conduit Entry: (2) 1/2" - 3/4" ports, (2) 3/4" ports

Secondary Conduit Entry: (2) 1/2" - 3/4" ports, (2) 3/4" ports

Overload Protection: Resettable (auto) thermal switch.

Model	Input 60 Hz.	Secondary Output	
		Lamp Watts (W)*	Voltage (VAC)
L VX50	120 VAC	50 Max.	12 / 13.5
L VX100	120 VAC	100 Max.	12 / 13.5

* Any combination of bulbs, any tap.

LIMITED THREE-YEAR WARRANTY

If within the warranty period specified, this product fails due to a defect in material or workmanship, Spa Electrics Pty Ltd will repair or replace it, at its sole option, free of charge. This warranty is extended to the original household purchaser only and is not transferable. This warranty does not apply to: (a) damage to units caused by accident, dropping or abuse in handling, acts of God or any negligent use; (b) units which have been subject to unauthorized repair, taken apart or otherwise modified; (c) units not used in accordance with instructions; (d) damages exceeding the cost of the product; (e) sealed lamps and/or lamp bulbs and LED's; (f) the finish on any portion of the product, such as surface and/or weathering, as this is considered normal wear and tear; (g) transit damage, initial installation costs, removal costs, or reinstallation costs.

SPA ELECTRICS PTY LTD WILL NOT BE LIABLE FOR INCIDENTAL OR CONSEQUENTIAL DAMAGES. SOME STATES DO NOT ALLOW THE EXCLUSION OR LIMITATION OF INCIDENTAL OR CONSEQUENTIAL DAMAGES, SO THE ABOVE LIMITATION OR EXCLUSION MAY NOT APPLY TO YOU. THIS WARRANTY IS IN LIEU OF ALL OTHER EXPRESS OR IMPLIED WARRANTIES. ALL IMPLIED WARRANTIES, INCLUDING THE WARRANTY OF MERCHANTABILITY AND THE WARRANTY OF FITNESS FOR A PARTICULAR PURPOSE, ARE HEREBY MODIFIED TO EXIST ONLY AS CONTAINED IN THIS LIMITED WARRANTY, AND SHALL BE OF THE SAME DURATION AS THE WARRANTY PERIOD STATED ABOVE. SOME STATES DO NOT ALLOW LIMITATIONS ON THE DURATION OF AN IMPLIED WARRANTY, SO THE ABOVE LIMITATION MAY NOT APPLY TO YOU.

This warranty claim is available by either (a) returning the product to the dealer from whom the unit was purchased or (b) completing a warranty claim online at www.spaelectrics.com.

Because of our commitment to continuing research and improvements, Spa Electrics Pty Ltd reserves the right to make changes, without notice, in the specifications and material contained herein and shall not be responsible for any damages, direct or consequential, caused by reliance on the material presented.