

4

3

2

1

ITEM NO.	PART NUMBER	DESCRIPTION	QTY.
1	O-SO-48H-84W-S	OPEN TOP 48H STAIR 84W SIDE	2
2	W-48H-36W	WALL	2
3	TSP-O-SO-48H-S-02	TREAD SUPPORT	2

B

B

A

A

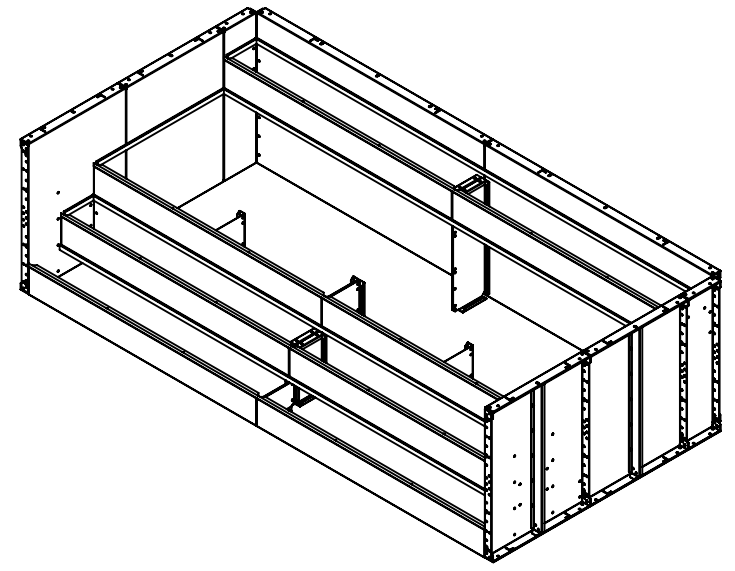
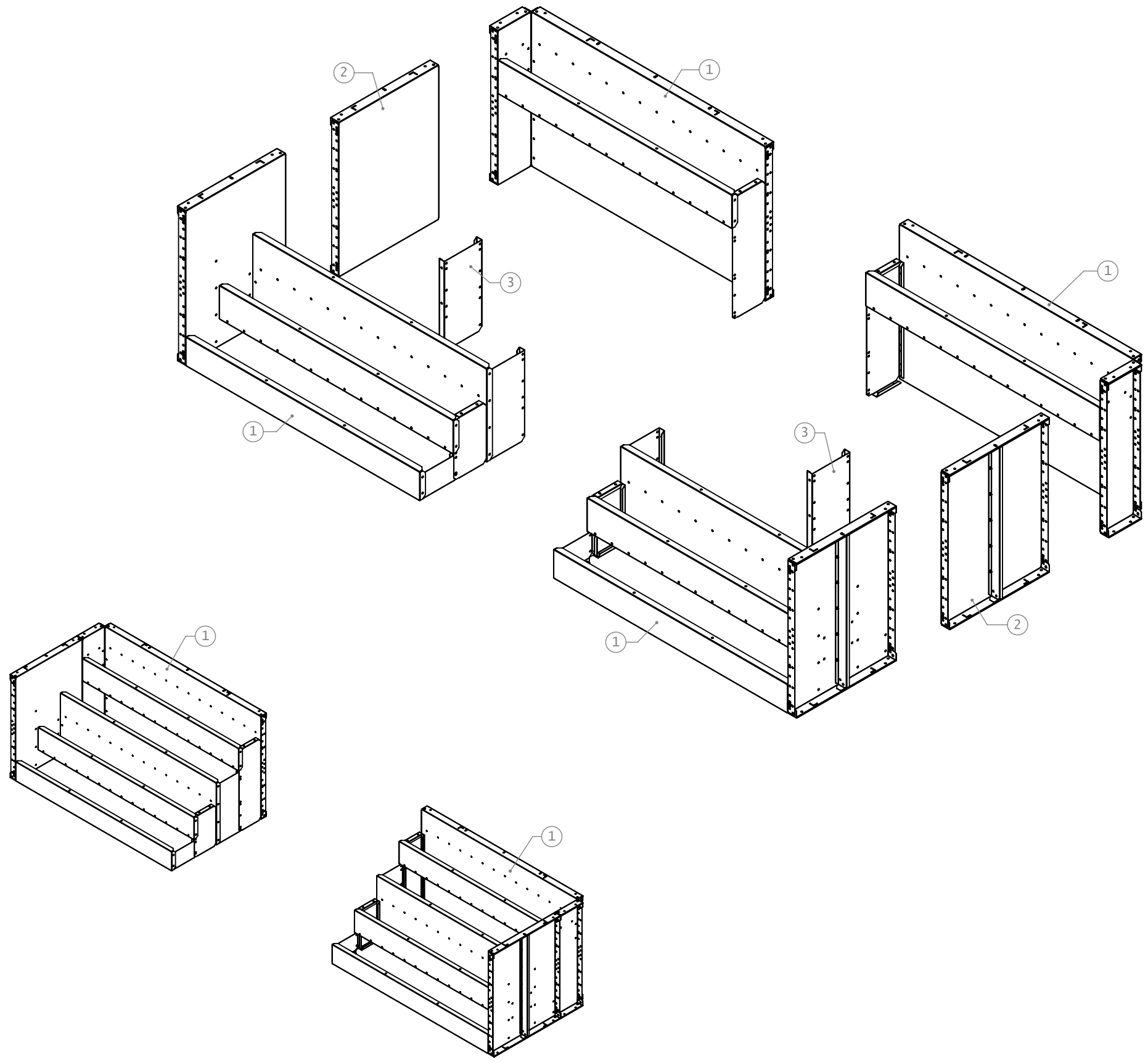

NOTE : SHIP AS KIT

4

3

2

1

REV	INFORMATION	DATE	BY
00	INITIAL RELEASE	06/11/2024	MM

THIRD ANGLE PROJECTION		THIS INFORMATION CONTAINED IN THE DRAWING IS THE SOLE PROPERTY OF C.L. MALACH, ANY REPRODUCTION IN PART OR WHOLE WITHOUT THE WRITTEN PERMISSION OF C.L. MALACH IS PROHIBITED.	
DIMENSIONAL UNITS INCH (MM)			
TOLERANCES U.O.S. IMPERIAL METRIC .X ± .100 X ± 2.50 .XX ± .030 X.X ± 0.80 .XXX ± .015 X.XX ± 0.40 FEATURES OF SIZE X.XXX X.XX +.005/- .003 +.13/- .08 ANGLES ± 1.0°	DESCRIPTION	REV.	
	OPEN TOP STAIR WITH 48W SUNLEDGE 168W	00	
SIZE	SCALE	SHEET	PART NO.
B	1:30	1 OF 2	O-SUN48-48H-168W

4

3

2

1

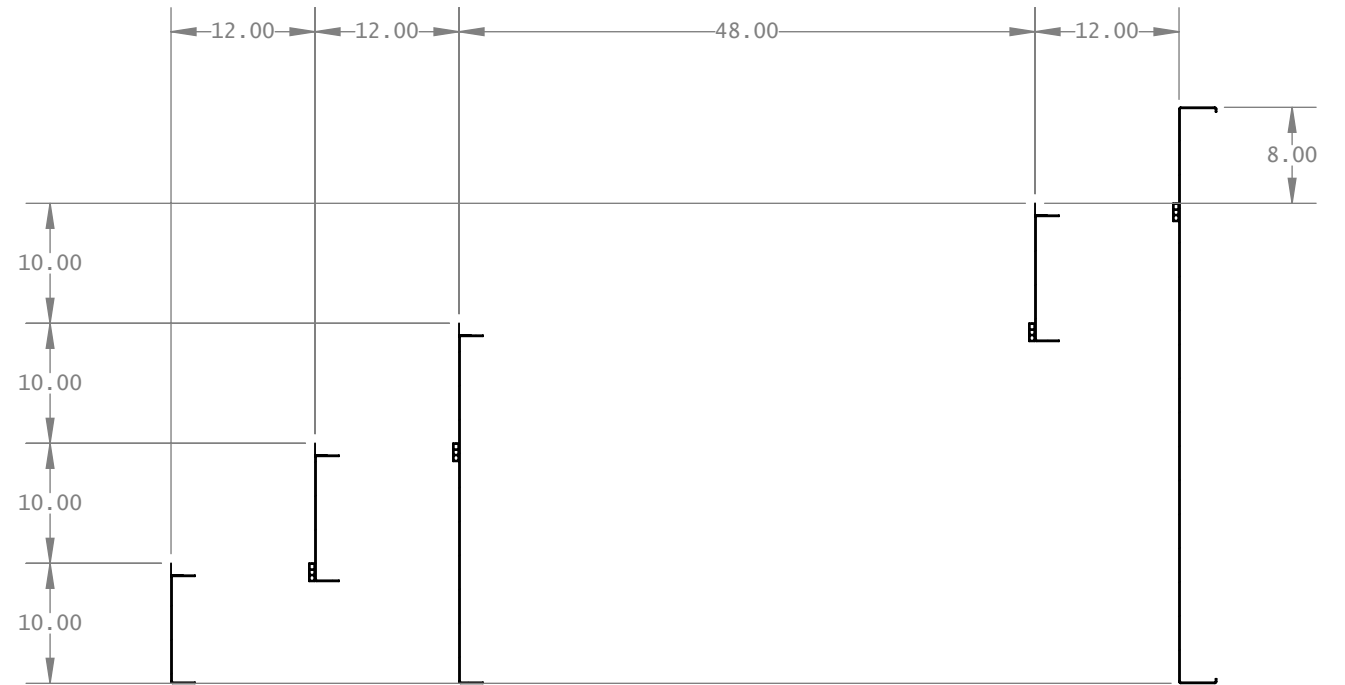
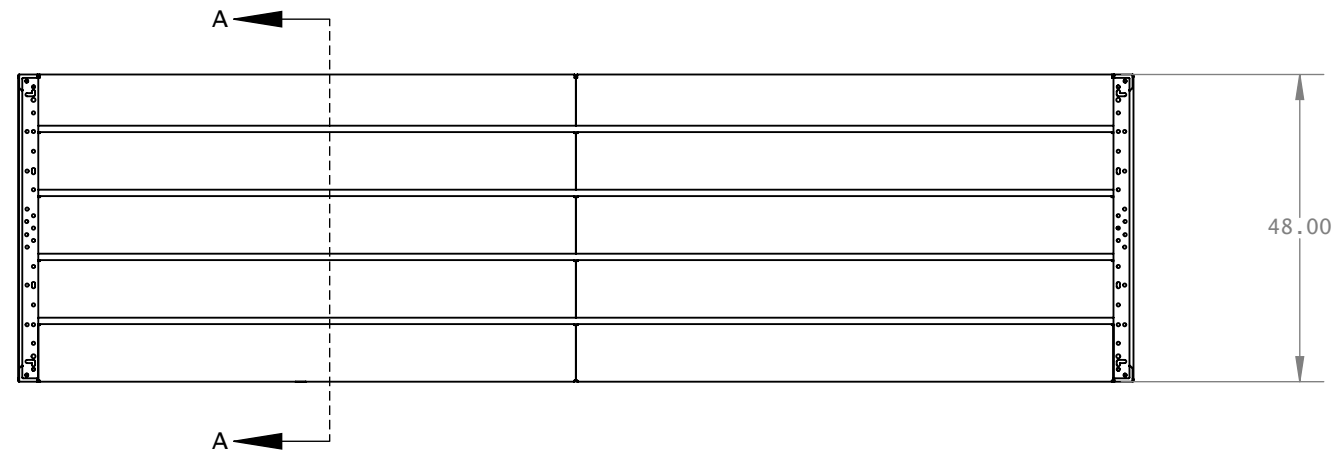
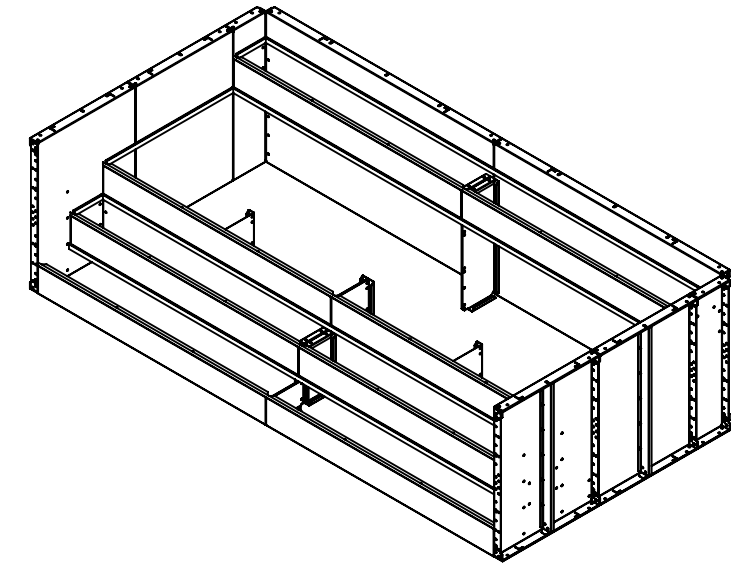
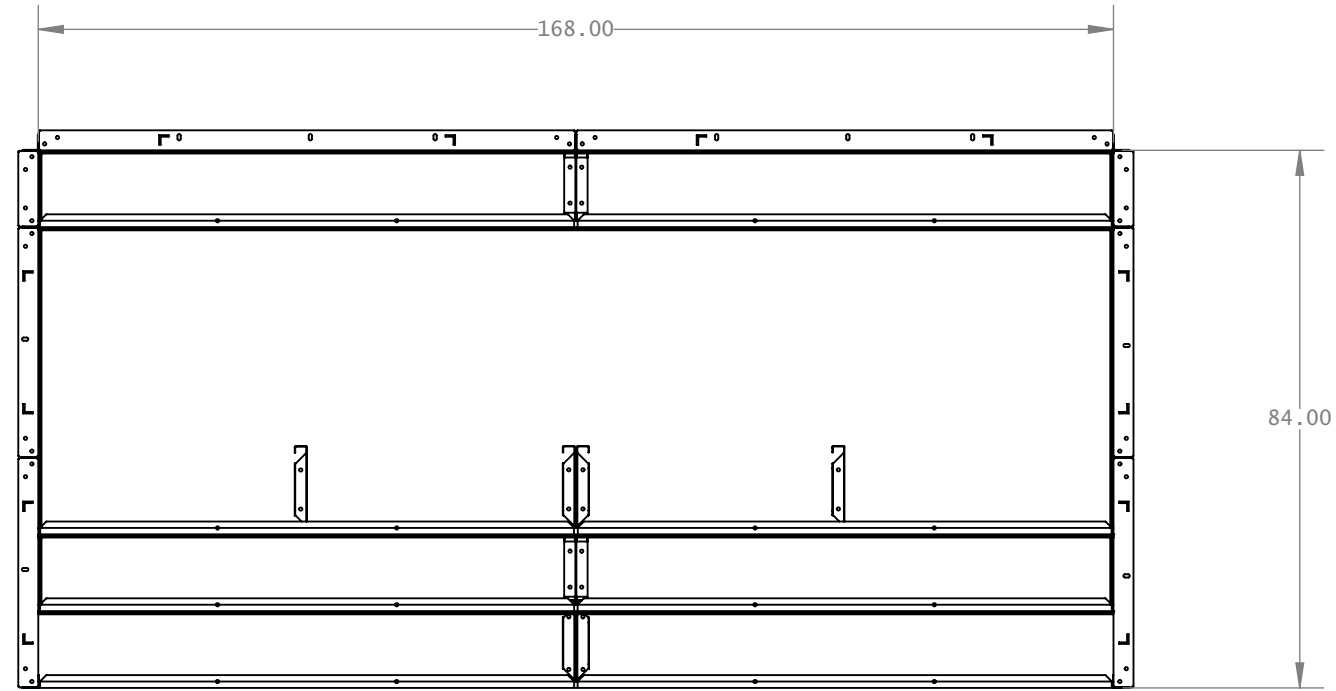

SECTION A-A
SCALE 1 : 16

NOTE : SHIP AS KIT

REV	INFORMATION	DATE	BY
00	INITIAL RELEASE	06/11/2024	MM

			THIS INFORMATION CONTAINED IN THE DRAWING IS THE SOLE PROPERTY OF C.L. MALACH, ANY REPRODUCTION IN PART OR WHOLE WITHOUT THE WRITTEN PERMISSION OF C.L. MALACH IS PROHIBITED.
DIMENSIONAL UNITS INCH (MM)			
TOLERANCES U.O.S. IMPERIAL METRIC .X ± .100 X ± 2.50 .XX ± .030 X.X ± 0.80 .XXX ± .015 X.XX ± 0.40		DESCRIPTION OPEN TOP STAIR WITH 48W SUNLEDGE 168W	
FEATURES OF SIZE X.XXX X.XX +.005/- .003 +.13/- .08 ANGLES ± 1.0°		SIZE B	SCALE 1:30
		SHEET 2 OF 2	PART NO. O-SUN48-48H-168W
			REV. 00

4

3

2

1