

ITEM NO.	PART NUMBER	DESCRIPTION	QTY.
1	O-SO-42H-96W-S	OPEN TOP STAIR 96W SIDE	2
2	W-42H-60W	WALL	2
3	TSP-O-SO-42H-S-01	TREAD SUPPORT	2

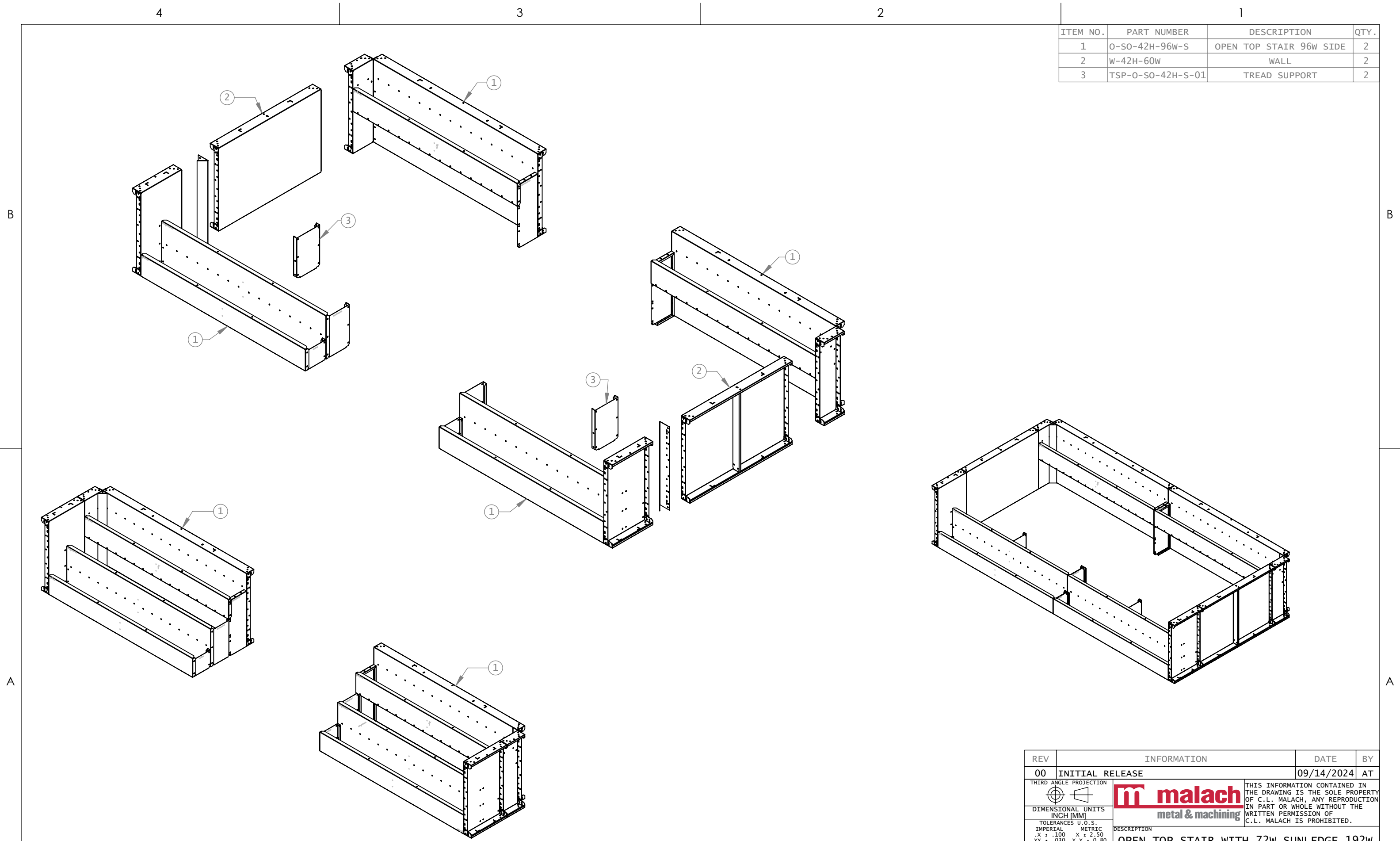

NOTE: SHIP AS KIT

REV	INFORMATION	DATE	BY
00	INITIAL RELEASE	09/14/2024	AT

THIRD ANGLE PROJECTION		THIS INFORMATION CONTAINED IN THE DRAWING IS THE SOLE PROPERTY OF C.L. MALACH, ANY REPRODUCTION IN PART OR WHOLE WITHOUT THE WRITTEN PERMISSION OF C.L. MALACH IS PROHIBITED.	
DIMENSIONAL UNITS INCH (MM)			
TOLERANCES U.O.S. IMPERIAL METRIC .X ± .100 X ± 2.50 .XX ± .030 X.X ± 0.80 .XXX ± .015 X.XX ± 0.40 FEATURES OF SIZE X.XXX X.XX +.005/- .003 +.13/- .08 ANGLES ± 1.0°	DESCRIPTION	REV.	
OPEN TOP STAIR WITH 72W SUNLEDGE 192W		00	
SIZE	SCALE	SHEET	PART NO.
B	1:35	1 OF 2	O-SUN72-42H-192W

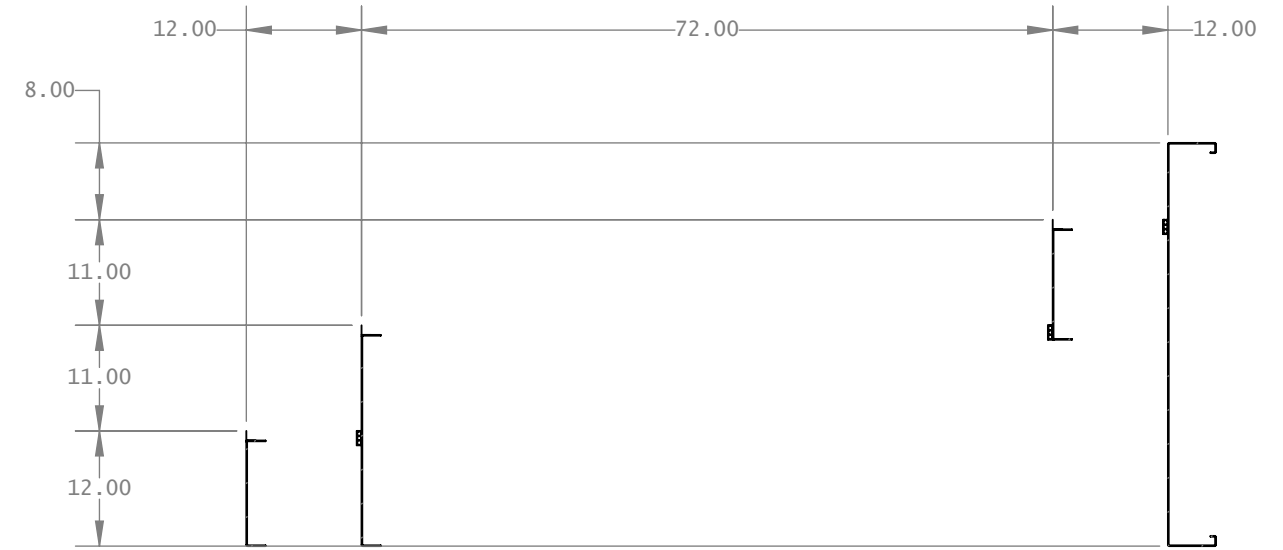
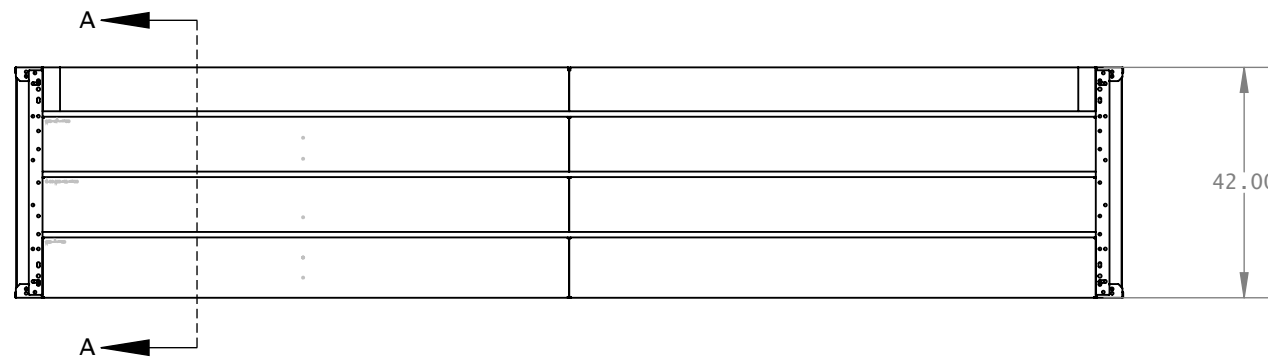
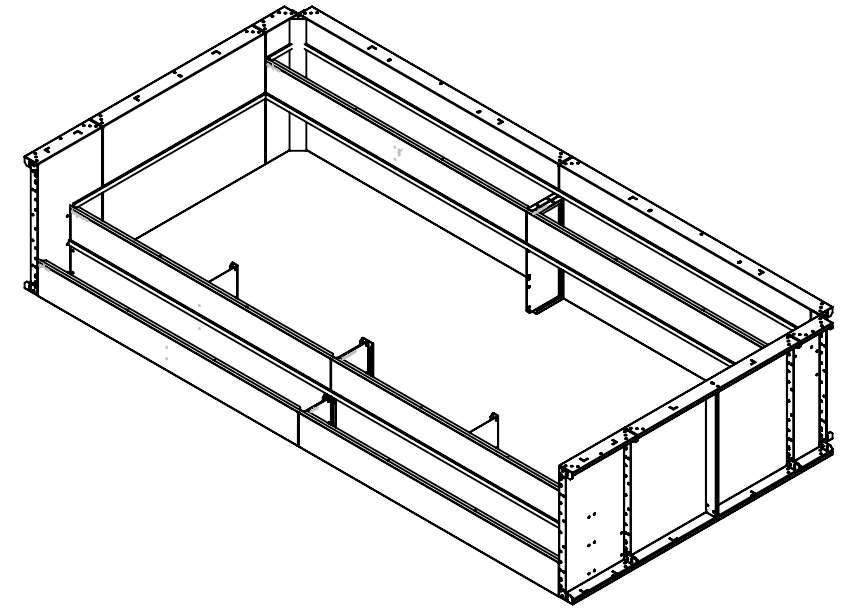
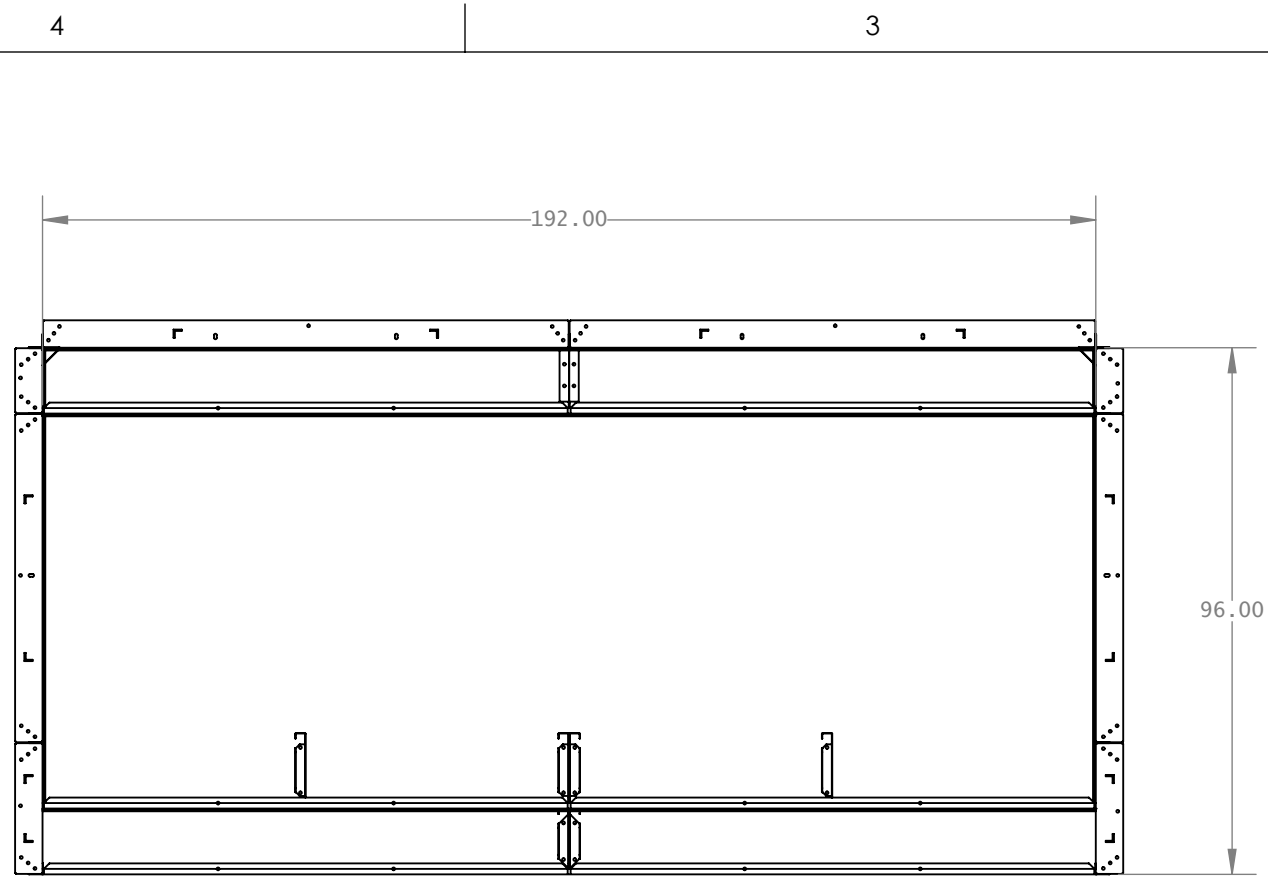

SECTION A-A  
SCALE 1 : 20

NOTE: SHIP AS KIT

REV	INFORMATION	DATE	BY
00	INITIAL RELEASE	09/14/2024	AT
THIRD ANGLE PROJECTION		<p>THIS INFORMATION CONTAINED IN THE DRAWING IS THE SOLE PROPERTY OF C.L. MALACH, ANY REPRODUCTION IN PART OR WHOLE WITHOUT THE WRITTEN PERMISSION OF C.L. MALACH IS PROHIBITED.</p>	
DIMENSIONAL UNITS INCH (MM)		DESCRIPTION <b>OPEN TOP STAIR WITH 72W SUNLEDGE 192W</b>	
TOLERANCES U.O.S. IMPERIAL METRIC .X ± .100 X ± 2.50 .XX ± .030 X.X ± 0.80 .XXX ± .015 X.XX ± 0.40 FEATURES OF SIZE X.XXX X.XX +.005/- .003 +.13/- .08 ANGLES ± 1.0°		SIZE <b>B</b>	SCALE 1:35
		SHEET 2 OF 2	PART NO. <b>O-SUN72-42H-192W</b>
			REV. 00