

ITEM NO.	PART NUMBER	DESCRIPTION	QTY.
1	O-SO-48H-96W-S	OPEN TOP 48H STAIR 96W SIDE	2
2	O-SO-48H-48W-C	OPEN TOP 48H STAIR 48W CENTER	1
3	W-48H-60W	WALL	2
4	TSP-O-SO-48H-S-02	TREAD SUPPORT	2

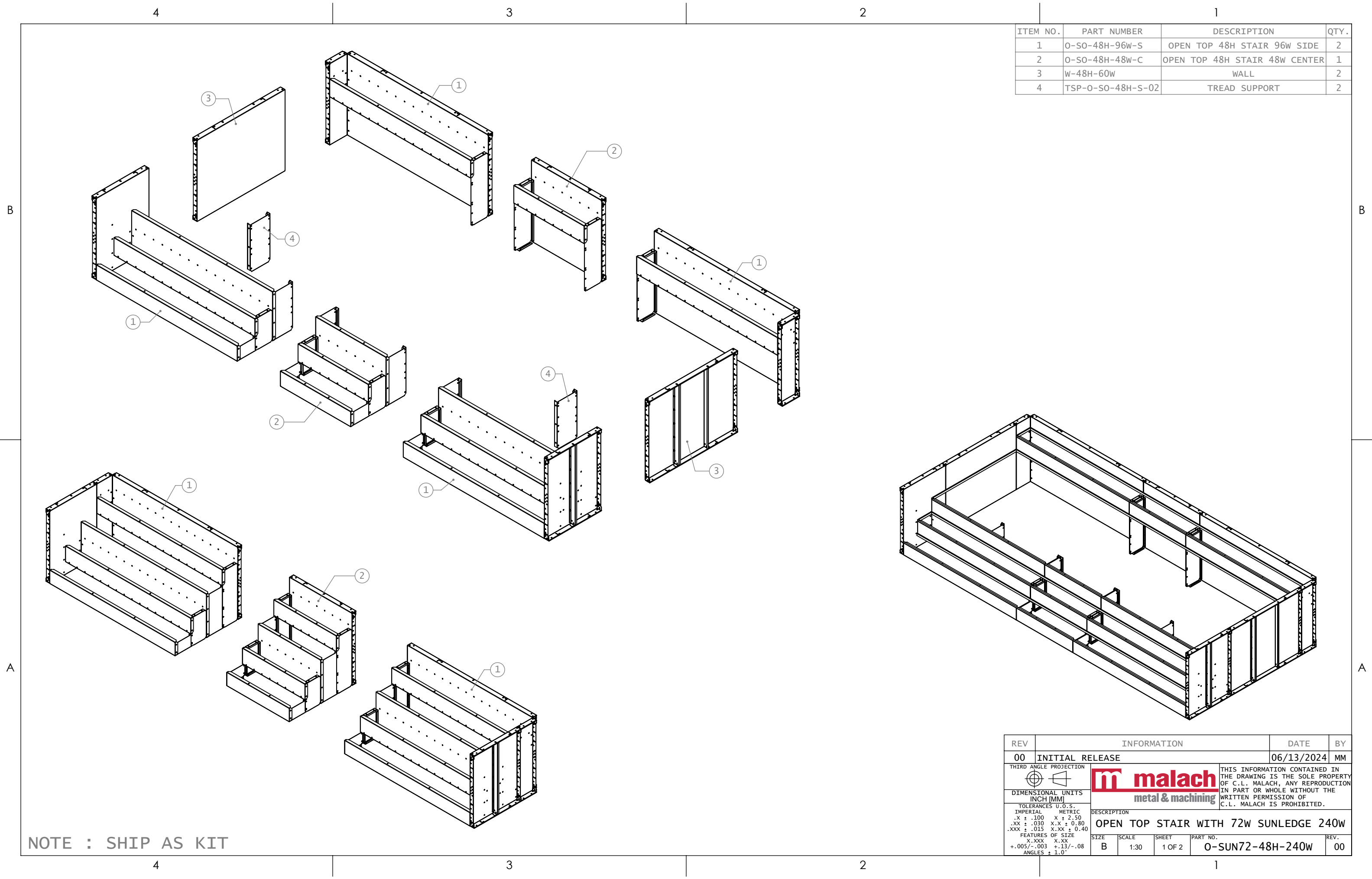

NOTE : SHIP AS KIT

REV	INFORMATION	DATE	BY
00	INITIAL RELEASE	06/13/2024	MM

THIRD ANGLE PROJECTION		THIS INFORMATION CONTAINED IN THE DRAWING IS THE SOLE PROPERTY OF C.L. MALACH, ANY REPRODUCTION IN PART OR WHOLE WITHOUT THE WRITTEN PERMISSION OF C.L. MALACH IS PROHIBITED.	
DIMENSIONAL UNITS INCH (MM)			
TOLERANCES U.O.S. IMPERIAL METRIC .X ± .100 X ± 2.50 .XX ± .030 X.X ± 0.80 .XXX ± .015 X.XX ± 0.40 FEATURES OF SIZE X.XXX X.XX +.005/- .003 +.13/- .08 ANGLES ± 1.0°	DESCRIPTION	REV.	
	OPEN TOP STAIR WITH 72W SUNLEDGE 240W	00	
SIZE	SCALE	SHEET	PART NO.
B	1:30	1 OF 2	O-SUN72-48H-240W

4

3

2

1

B

B

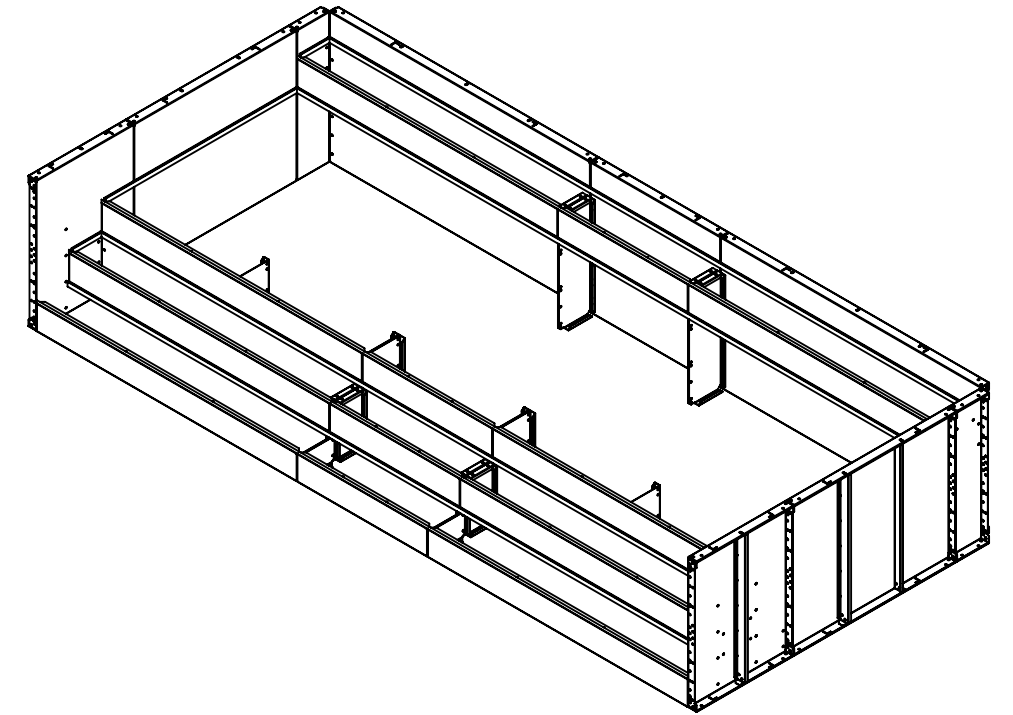
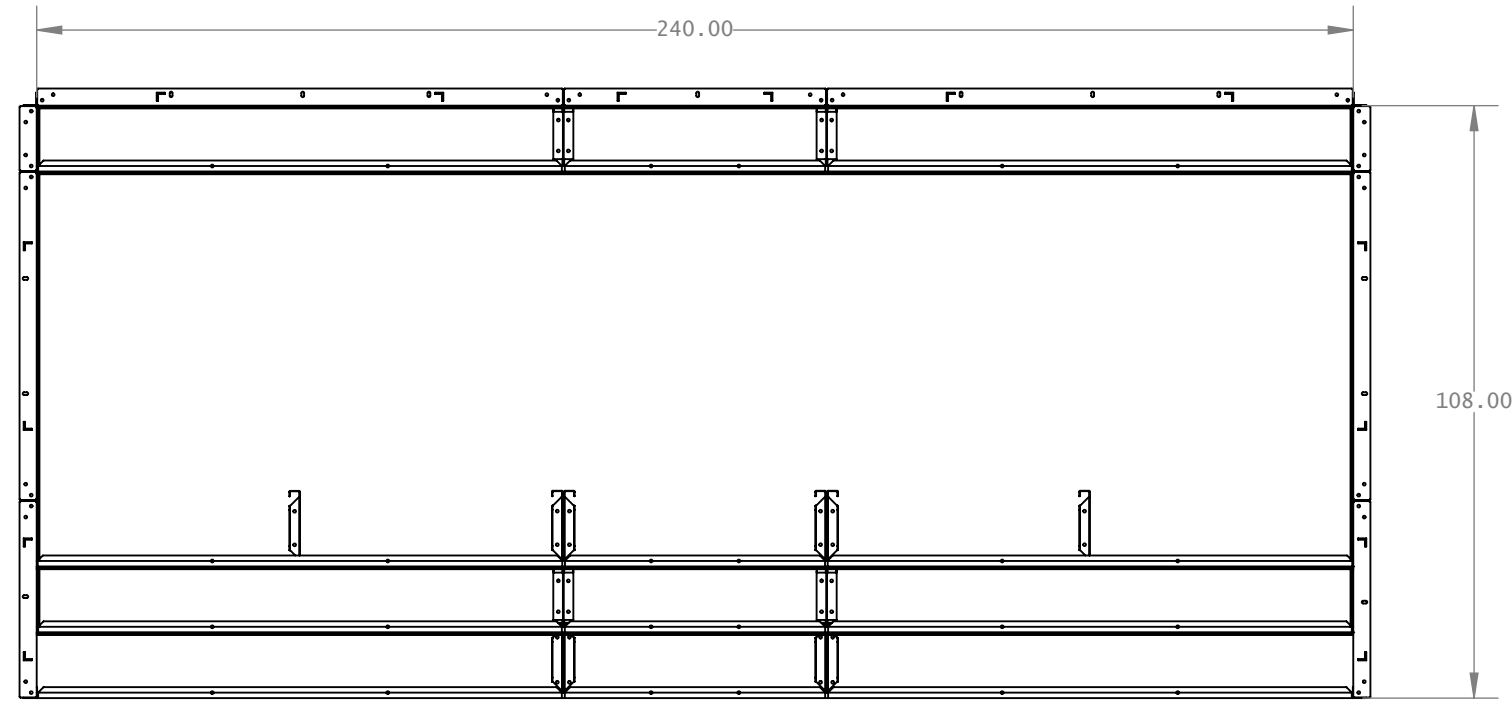

A

A

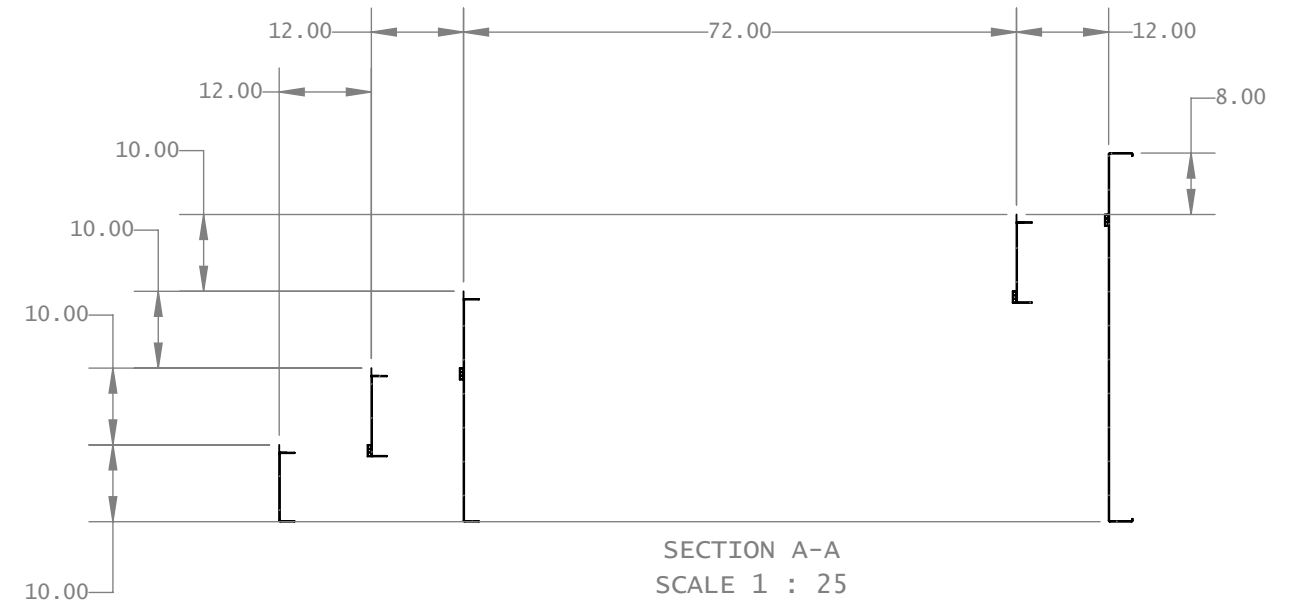
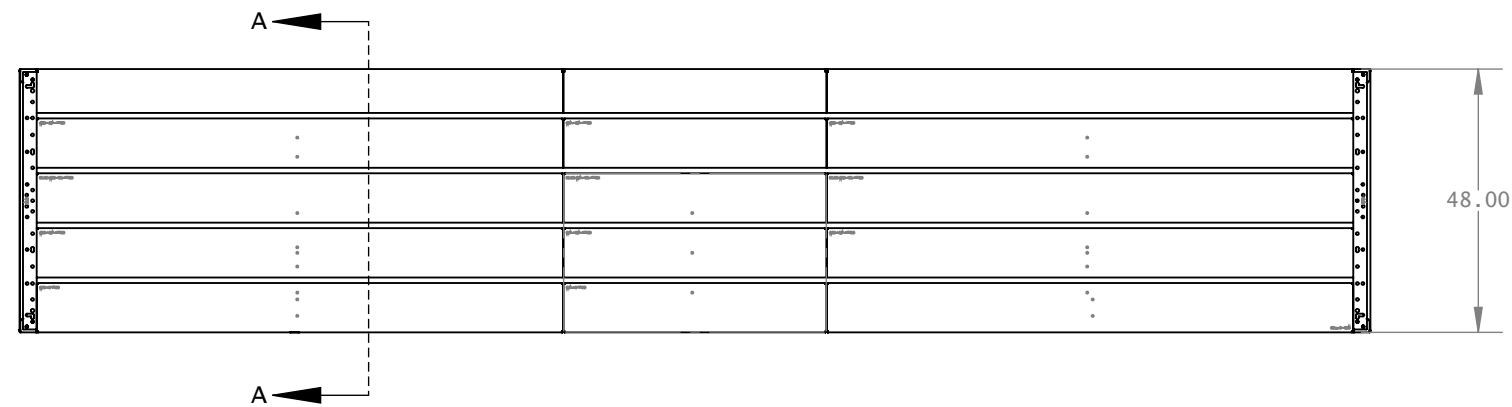

NOTE : SHIP AS KIT

4

3

2

1

REV	INFORMATION	DATE	BY
00	INITIAL RELEASE	06/13/2024	MM

THIRD ANGLE PROJECTION			THIS INFORMATION CONTAINED IN THE DRAWING IS THE SOLE PROPERTY OF C.L. MALACH, ANY REPRODUCTION IN PART OR WHOLE WITHOUT THE WRITTEN PERMISSION OF C.L. MALACH IS PROHIBITED.
DIMENSIONAL UNITS INCH (MM)			
TOLERANCES U.O.S. IMPERIAL METRIC .X ± .100 X ± 2.50 .XX ± .030 X.X ± 0.80 .XXX ± .015 X.XX ± 0.40 FEATURES OF SIZE X.XXX X.XX +.005/- .003 +.13/- .08 ANGLES ± 1.0°		DESCRIPTION	REV.
OPEN TOP STAIR WITH 72W SUNLEDGE 240W		SIZE B SCALE 1:30 SHEET 2 OF 2 PART NO. O-SUN72-48H-240W	00