

4

3

2

1

ITEM	PART NO.	DESCRIPTION	QTY
1	O-SO-48H-2R-LH	OPEN TOP 48H-24R CORNER STAIRS LH	1
2	O-SO-48H-2R-RH	OPEN TOP 48H-24R CORNER STAIRS RH	1
3	O-SO-48H-48W-C	OPEN TOP 48H STAIR 48W CENTER	1
4	W-48H-60W	WALL	2

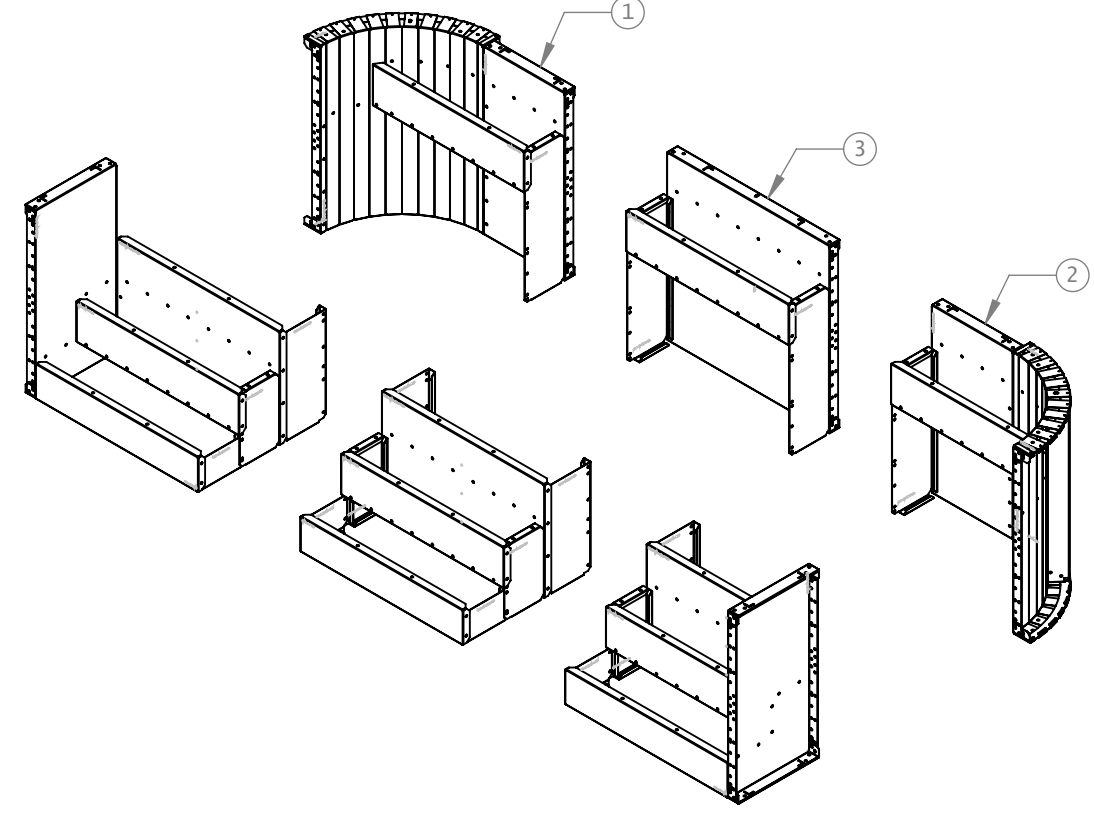
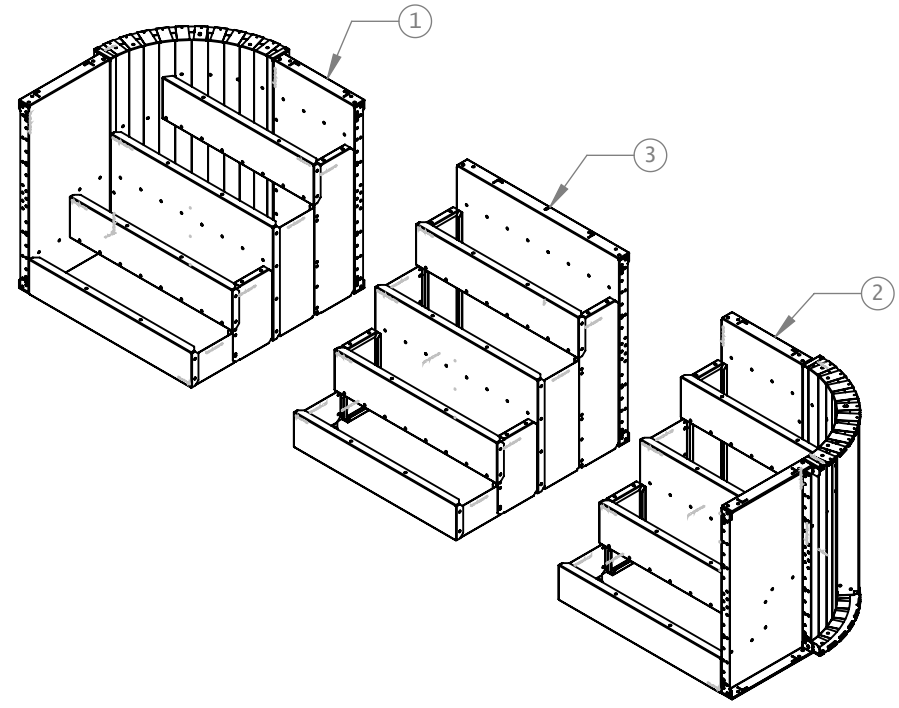

NOTE: HOLES ON OUTSIDE WALL TO BE DRILLED ON SITE TO CONNECT THE STAIR TO THE WALL

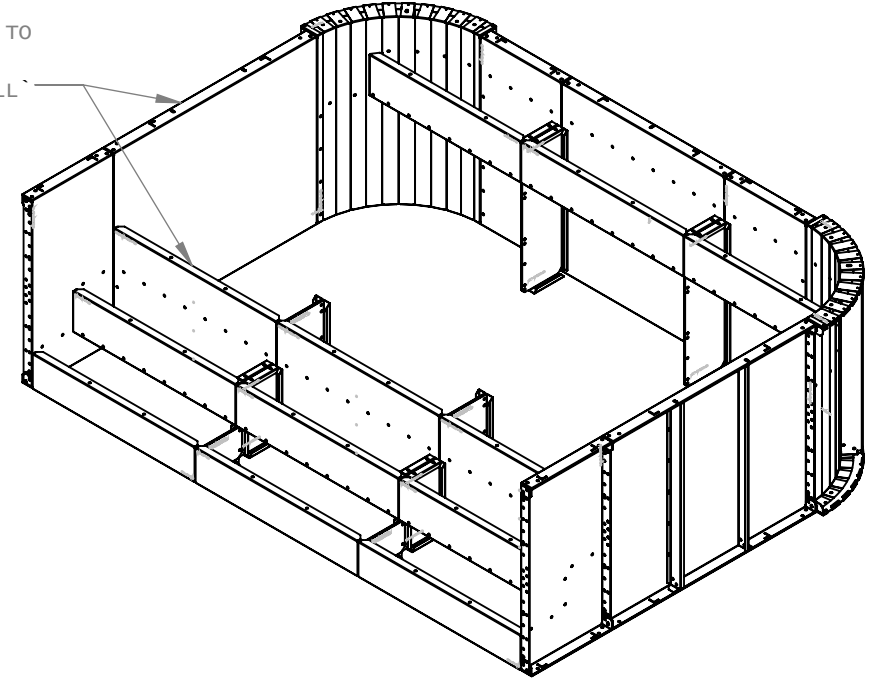
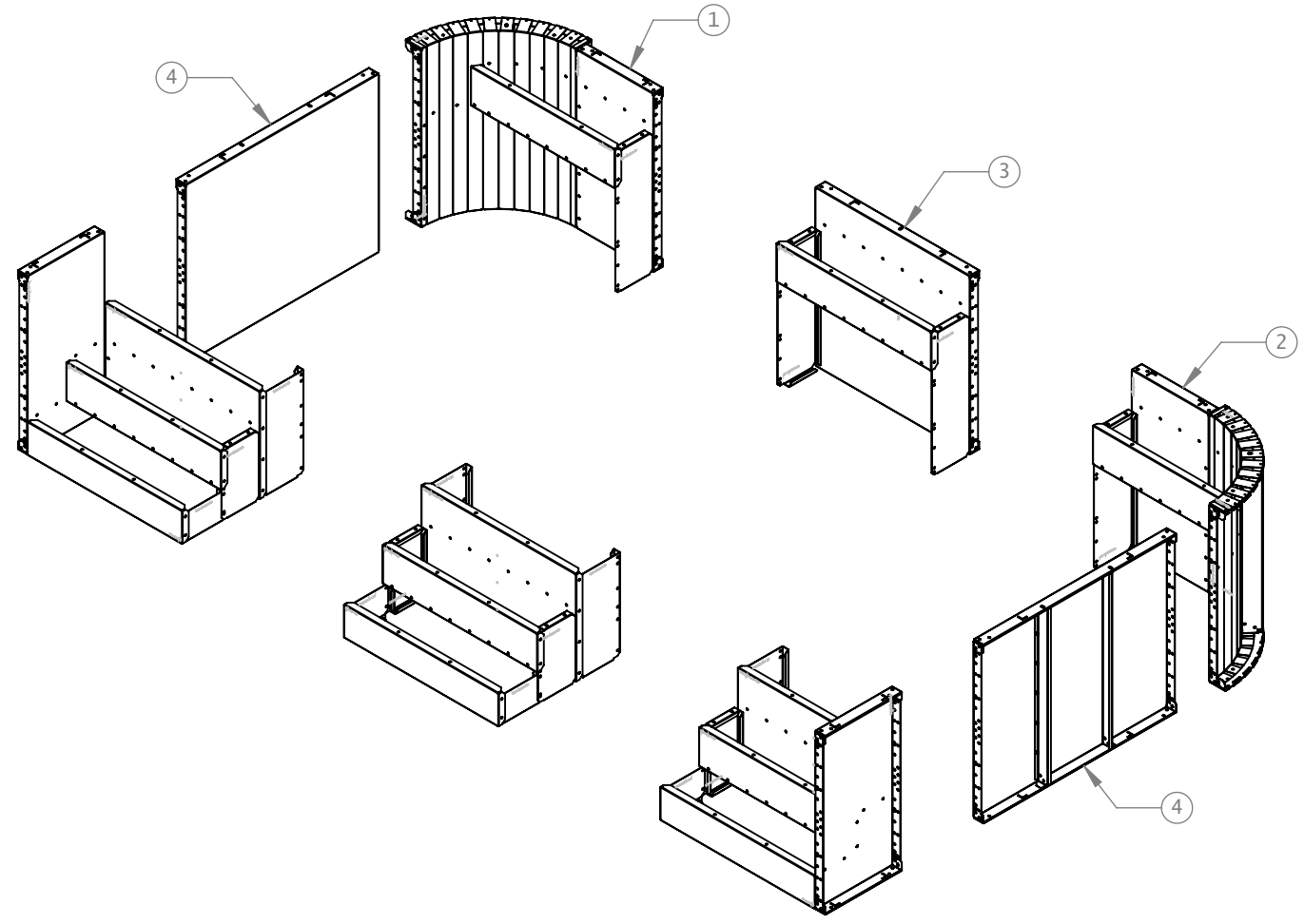

NOTES: SHIP AS A KIT

REV	INFORMATION	DATE	BY	APP
00	INITIAL RELEASE	08/03/2024	AT	

THIRD ANGLE PROJECTION		THIS INFORMATION CONTAINED IN THE DRAWING IS THE SOLE PROPERTY OF C.L. MALACH, ANY REPRODUCTION IN PART OR WHOLE WITHOUT THE WRITTEN PERMISSION OF C.L. MALACH IS PROHIBITED.	
DIMENSIONAL UNITS INCH (MM)			
TOLERANCES U.O.S. IMPERIAL X ± .060 METRIC X ± 1.50 .XX ± .030 X.X ± 0.80 .XXX ± .015 X.XX ± 0.40 CRITICAL HOLES +.005/- .003 +.13/- .08 ANGLES ± 1.0°	DESCRIPTION	LEGE	
SIZE B	SCALE 1:40	SHEET 1 OF 2	PART NO. O-SUN72-48H-24R-144W
			REV. 00

4

3

2

1

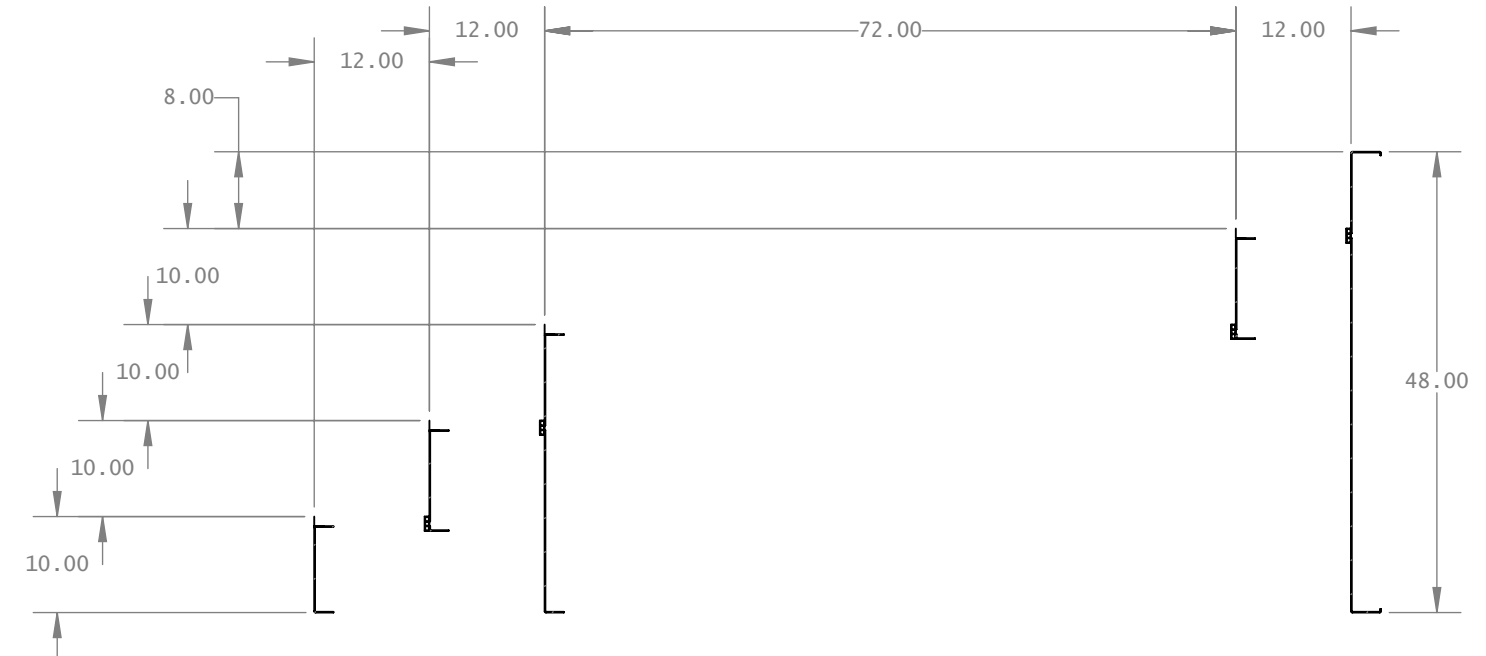
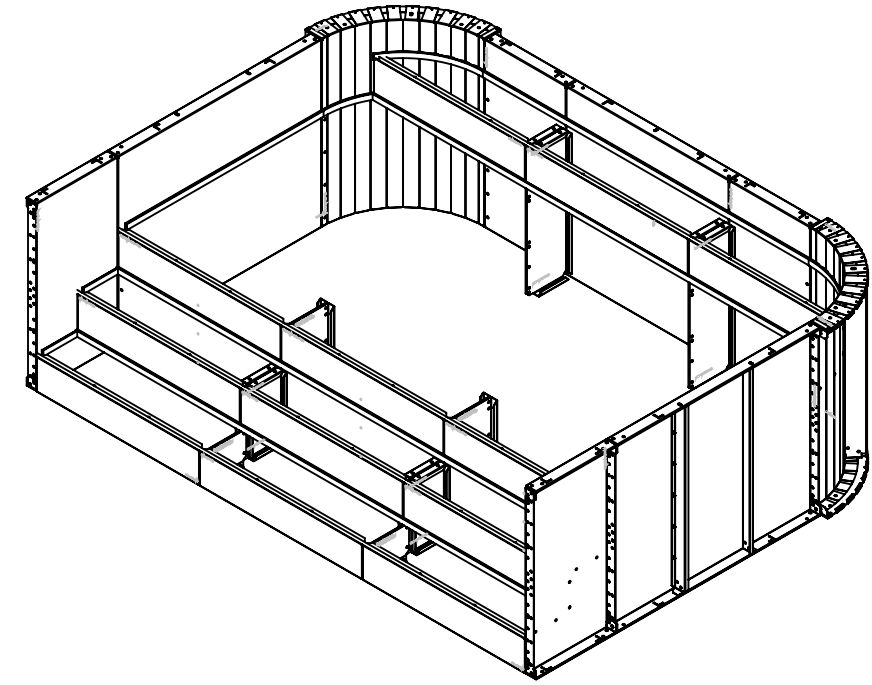
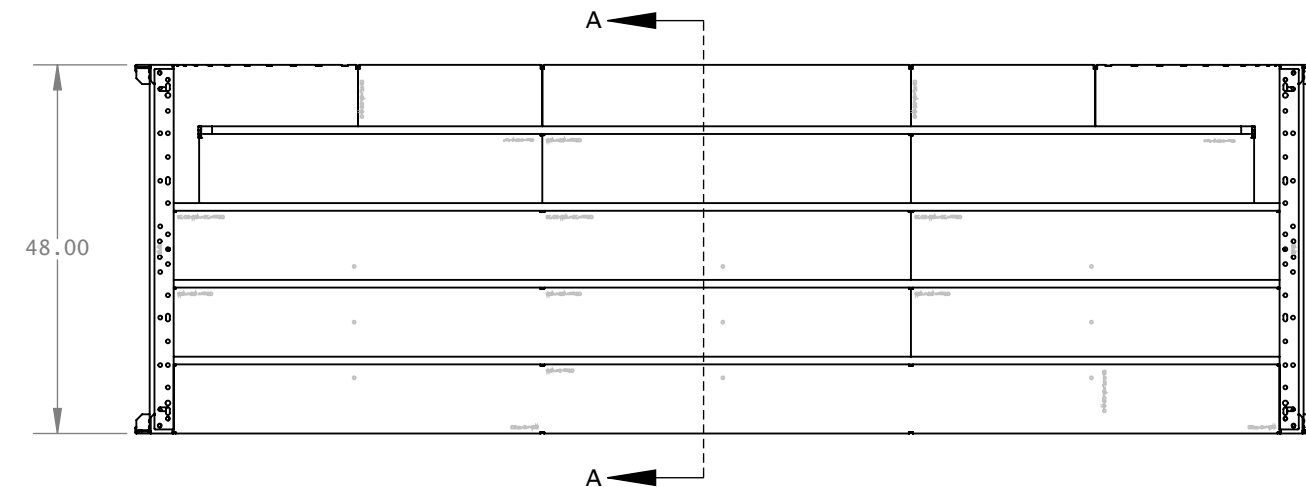
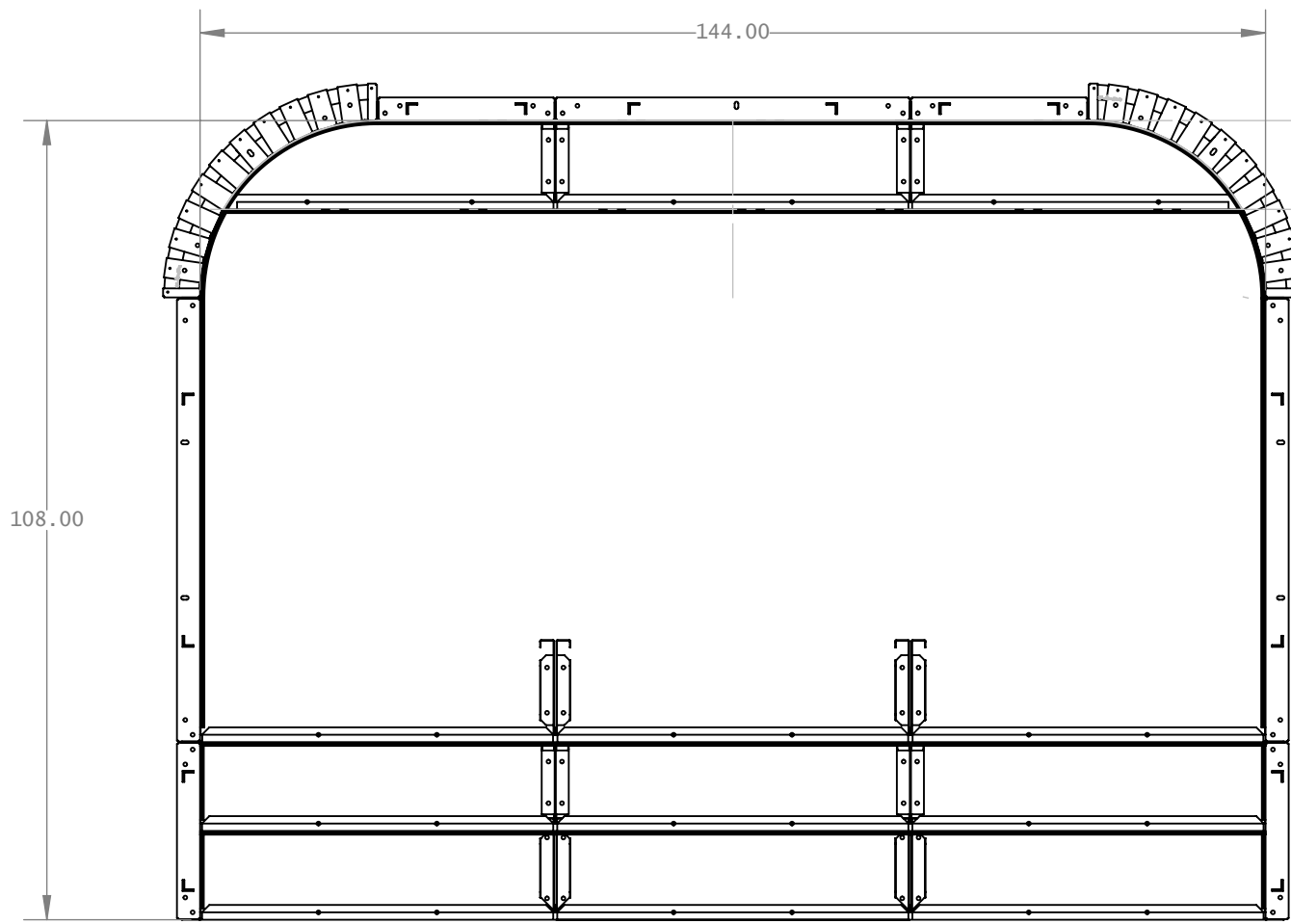

SECTION A-A
SCALE 1 : 20

NOTES: SHIP AS A KIT

REV	INFORMATION	DATE	BY	APP
00	INITIAL RELEASE	08/03/2024	AT	

<p>THIRD ANGLE PROJECTION</p>		<p>THIS INFORMATION CONTAINED IN THE DRAWING IS THE SOLE PROPERTY OF C.L. MALACH, ANY REPRODUCTION IN PART OR WHOLE WITHOUT THE WRITTEN PERMISSION OF C.L. MALACH IS PROHIBITED.</p>
<p>DIMENSIONAL UNITS INCH [MM]</p>		
<p>TOLERANCES U.O.S. IMPERIAL METRIC .X ± .060 X ± 1.50 .XX ± .030 X.X ± 0.80 .XXX ± .015 X.XX ± 0.40 CRITICAL HOLES +.005/- .003 +.13/- .08 ANGLES ± 1.0°</p>	<p>DESCRIPTION</p> <p>LEDGE</p>	<p>SIZE SCALE SHEET PART NO. REV.</p> <p>B 1:40 2 OF 2 O-SUN72-48H-24R-144W 00</p>