

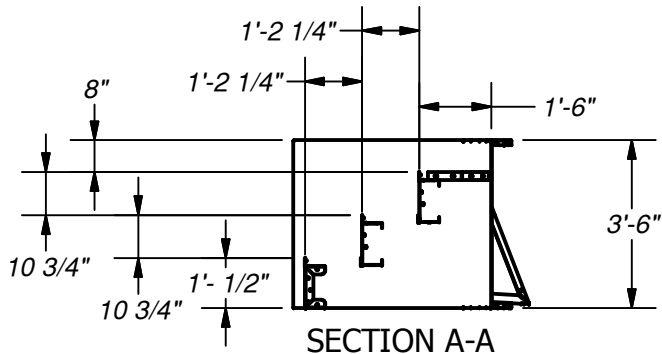

Name: 2'-0" RADIUS POURED CORNER STEP

Number: S0940CP34220RX0

250 Route 61 South, Schuylkill Haven, PA 17972 • 570-385-4733 • fax: 570-385-1318 • CustomerService@CardinalSystemsinc.com

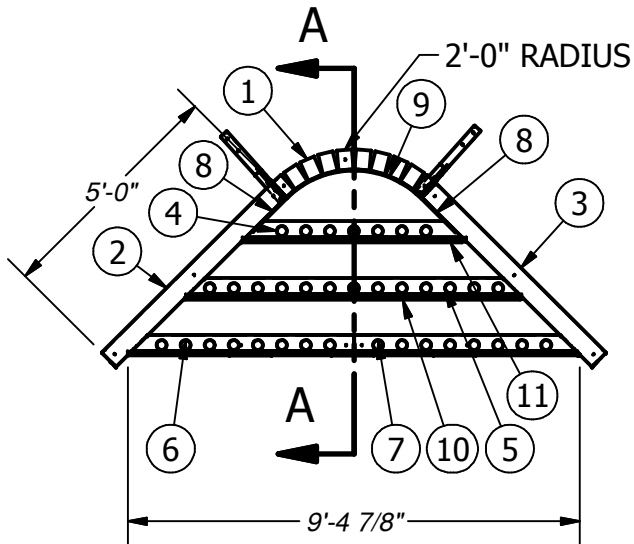

PARTS LIST			
ITEM	PART NUMBER	QTY	DESCRIPTION
1	SP0069	1	3'-1 5/8" X 2'-0" RADIUS STEP PANEL
2	SP2595	1	5'-0" STEP PANEL
3	SP2312	1	5'-0" STEP PANEL
4	PT5252	1	4'-7 7/8" POURED TREAD
5	PT5253	1	7'-0 3/8" POURED TREAD
6	PT2435	1	4'-8 1/2" POURED TREAD
7	PT2436	1	4'-8 1/2" POURED TREAD
8	LT0028	2	1'-0" LINER TRACK
9	LT0080	1	3'-1" x 2'-0" RADIUS LINER TRACK
10	LT0023	1	7'-0" LINER TRACK
11	LT0883	1	4'-7 1/2" LINER TRACK
	CS600OPT	2	A-FRAME TURNBUCKLE ASSEMBLY
	SP0745-6N-3	2	BOX OF 3 - 6'-0" SCREED EDGE
	CS608DH	2	18" DRIVE STAKE
	B9106ST	1	LARGE STEP BOLT PACK
	BP000TS	1	BOX OF TEK SCREWS

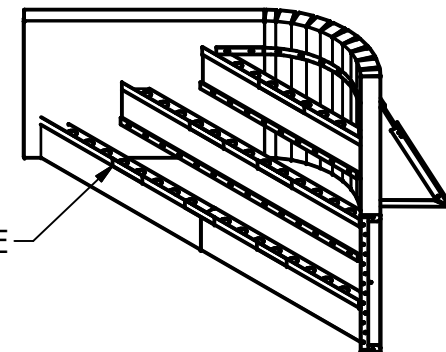

SCREED EDGE

NOTE:
USE REBAR HOLE LOCATIONS TO PIN WALL AND STEP DECK SUPPORTS IN PLACE. THEN POUR 4"-6" OF CONCRETE AROUND THESE AREAS AND UNDER THE ASSEMBLY FOR REINFORCEMENT

Drawn By: jschaeffer

Date: 12/18/2017

Scale: SCALE

Notes: NOTES

This information is the confidential property of Cardinal Systems, Inc. Disclosure or duplication without proper written approval is strictly prohibited. Acceptance and use of this drawing constitutes knowledge and acceptance by the user of the terms and conditions set forth in the notice and warning which accompanied this drawing is incorporated herein and made part hereof and is found on Cardinal Systems, Inc's website at www.CardinalSystemsInc.com



CardinalSystemsInc.com