

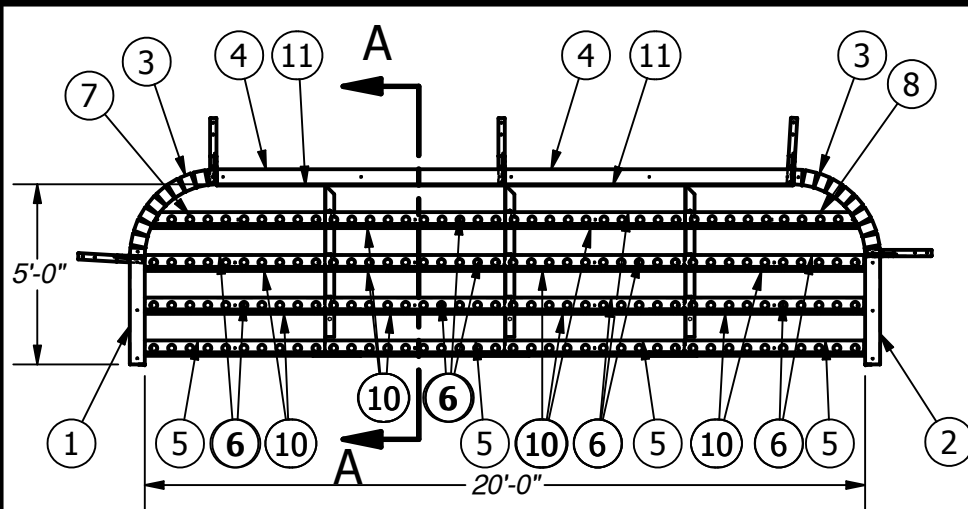

Name: 20'-0" POURED STEP W/ 2' RADIUS CORNERS (48")

Number: S2000SP44820RX2Z

250 Route 61 South, Schuylkill Haven, PA 17972 • 570-385-4733 • fax: 570-385-1318 • CustomerService@CardinalSystemsinc.com



PARTS LIST			
ITEM	PART NUMBER	QTY	DESCRIPTION
1	SP2196	1	3'-0" STEP PANEL (48")
2	SP2197	1	3'-0" STEP PANEL (48")
3	SP1843	2	3'-1 3/4" X 2'-0" RADIUS
4	SP0458	2	8'-0" STEP PANEL W/ 2Z (48")
5	PT4614	4	5'-0" POURED TREAD (10 1/4")
6	PT5321	10	5'-0" POURED TREAD (9 1/4")
7	PT5344	1	4'-9 7/8" POURED TREAD
8	PT5345	1	4'-9 7/8" POURED TREAD
9	TS0340	3	4'-9" POURED TREAD SUPPORT
10	LT0020	10	5'-0" LINER TRACK
11	LT0024	2	8'-0" LINER TRACK
12	LT0889	2	4'-9 1/2" LINER TRACK
	SP0745-6N-3	5	BOX OF 3 - 6'-0" SCREED EDGE
	CS600OPT	5	A-FRAME TURNBUCKLE ASSEMBLY
	CS608DH	5	18" DRIVE STAKE
	BP106ST	2	LARGE STEP BOLT PACK
	BP000TS	2	BOX OF TEK SCREWS

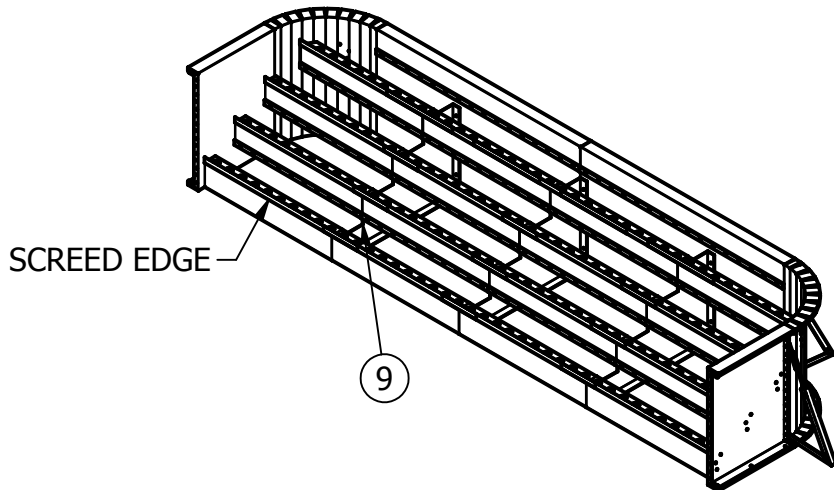
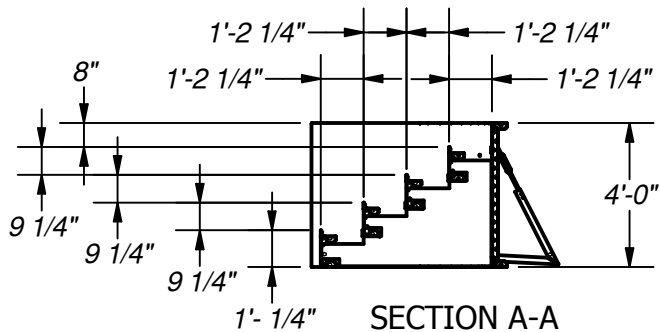

NOTE:
USE REBAR HOLE LOCATIONS TO PIN WALL AND STEP DECK SUPPORTS IN PLACE. THEN POUR 4"-6" OF CONCRETE AROUND THESE AREAS AND UNDER THE ASSEMBLY FOR REINFORCEMENT

Drawn By: jschaeffer	Date: 1/5/2018
Scale: SCALE	Notes: NOTES

This information is the confidential property of Cardinal Systems, Inc. Disclosure or duplication without proper written approval is strictly prohibited. Acceptance and use of this drawing constitutes knowledge and acceptance by the user of the terms and conditions set forth in the notice and warning which accompanied this drawing is incorporated herein and made part hereof and is found on Cardinal Systems, Inc's website at www.CardinalSystemsInc.com



CardinalSystemsInc.com