

## OT STEP 2'R CORNER 3 TRD 16' W/4' T2



TOLERANCES EXCEPT AS NOTED:

0/0 0.0 0.00 0.000 0°

±1/8 ±0.25 ±0.0625 ±0.03125 ±1/2°

**DATE :** 2/28/2019

**PART #:** SOK-DSST192R2XB

**SHEET :** 1 OF 2

**SECTION:**

Parts List		
ITEM	QTY	PART NUMBER
1	54	COP-KCVRET-W-1
2	48'	OPC-CONREC-120
3	56'	SSC-1099
4	1	SSC-3097
5	1	SSC-3099
6	1	SSC-3104
7	1	SSC-3105
8	1	SSC-3106
9	1	SSC-3107
10	1	SSC-3108
11	1	SSC-3109
12	2	SSC-3110
13	2	SSC-3111
14	2	SSC-3112
15	2	SSC-3113
16	2	SSC-3114
17	2	SSC-3116
18	2	SSC-3117
19	2	SSC-3124
20	1	SSC-3127
21	1	SSC-3128

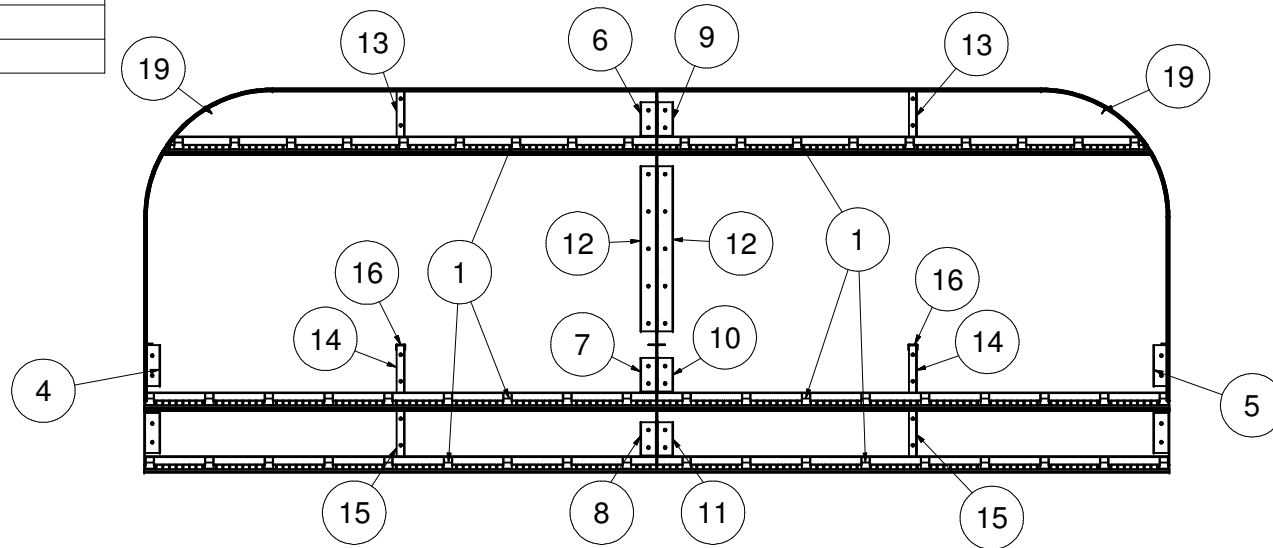
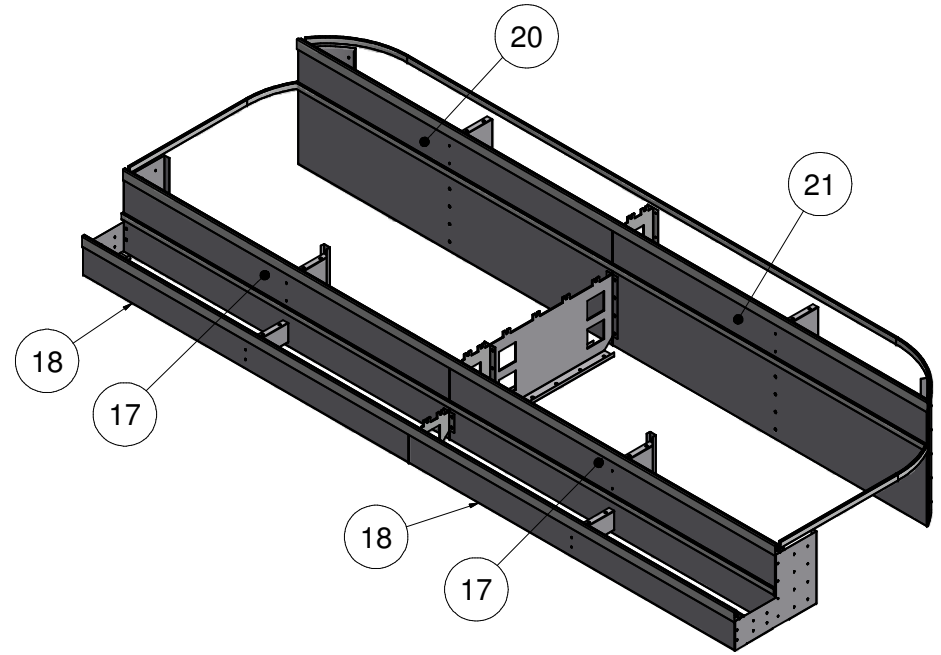

## OT STEP 2'R CORNER 3 TRD 16' W/4' T2



TOLERANCES EXCEPT AS NOTED:

0/0 0.0 0.00 0.000 0°  
±1/8 ±0.25 ±0.0625 ±0.03125 ±1/2°

**DATE : 2/28/2019**

**PART #: SOK-DSST192R2XB**

**SHEET : 2 OF 2**

**SECTION:**