

REVISION HISTORY		
REV	DESCRIPTION	DATE
0		2/17/2017

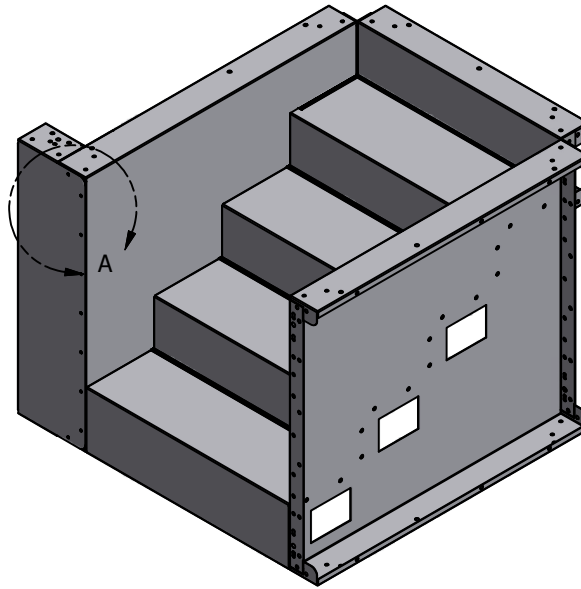

SWEDGE BOLTS

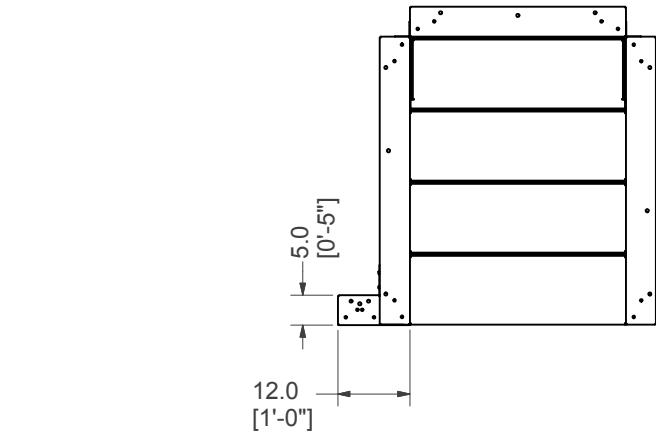
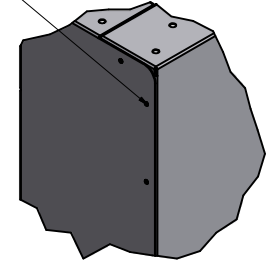

DETAIL A
SCALE 1 / 6

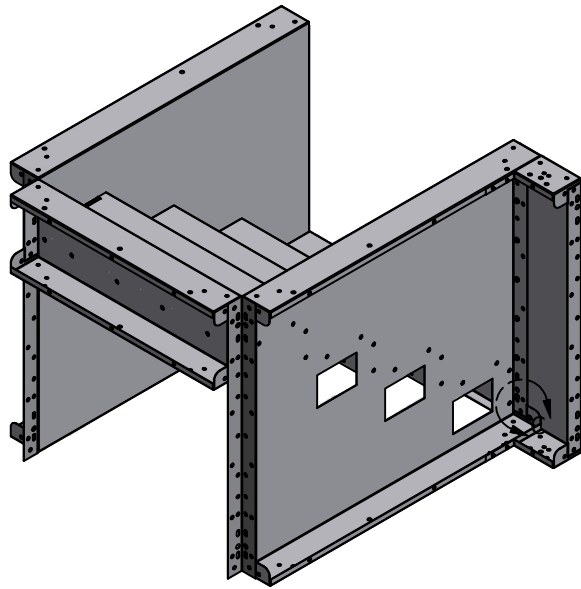

TEK SCREWS
TOP+BOTTOM

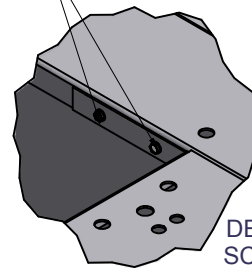

DETAIL B
SCALE 1/3

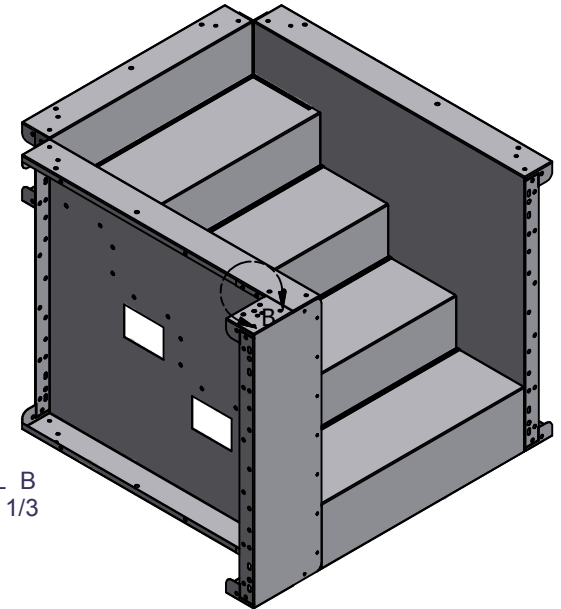

WASHER AND NUT
ON BACKSIDE

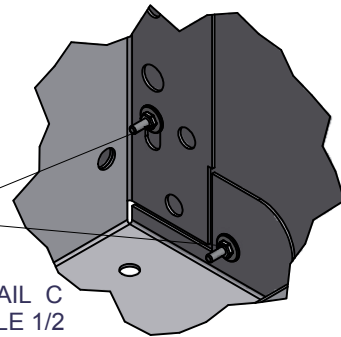

DETAIL C
SCALE 1/2

SSC-TRST1212 ATTACHED TO STOCK STEEL STEP

PART #:
SSC-TRT1212-ASSEMBLY

WEIGHT:
220.42 lbmass

MACHINE TIME:

FILE/DIRECTORY:

C:\Users\gbaird1\Desktop\NEW TRANSITION PANEL
ASSEMBLY\SSC-TRT1212-ASSEMBLY.idw



TOLERANCES EXCEPT
AS NOTED
0.0 0.00 0.000 0.0000 0'
±1/4 ±1/8 ±1/16 ±1/32 ±1/2"

MATERIAL:

DATE:
2/17/2017

NOTES:

DRAWN BY:
GBAIRD

SHEET:
1 OF 3

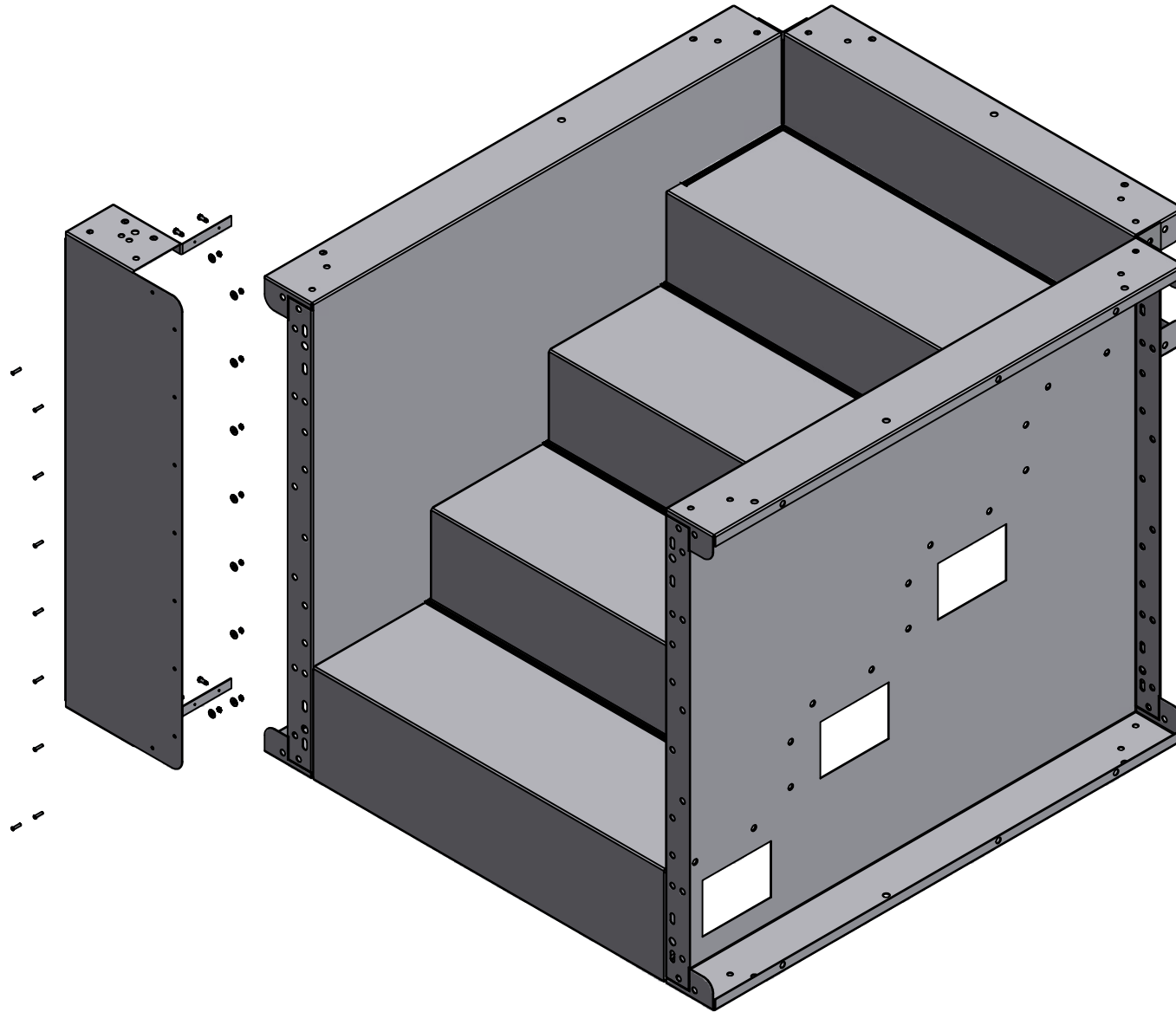

SSC-TRT1212 ATTACHED TO STOCK STEEL STEP

PART #:
SSC-TRT1212-ASSEMBLY

WEIGHT:
220.42 lbmass

MACHINE TIME:

FILE/DIRECTORY:

C:\Users\gbaird1\Desktop\NEW TRANSITION PANEL
ASSEMBLY\SSC-TRT1212-ASSEMBLY.idw



TOLERANCES EXCEPT
AS NOTED
0.0 0.00 0.000 0.0000 0'
±1/4 ±1/8 ±1/16 ±1/32 ±1/2"

MATERIAL:

DATE :
2/17/2017

NOTES:

DRAWN BY:
GBAIRD

SHEET :
2 OF 3

