

KEEP BEAD RECEIVERS ATTACHED TO THE RISERS AND WALLS FOR SHIPPING. A TOTAL OF 1056" (88') OF BEAD RECEIVER IS REQUIRED.

NOTE:
RIGHT AND LEFT SIDE PARTS ARE SYMMETRICAL.

PLEASE REFER TO:
CONTRACTOR NOTE

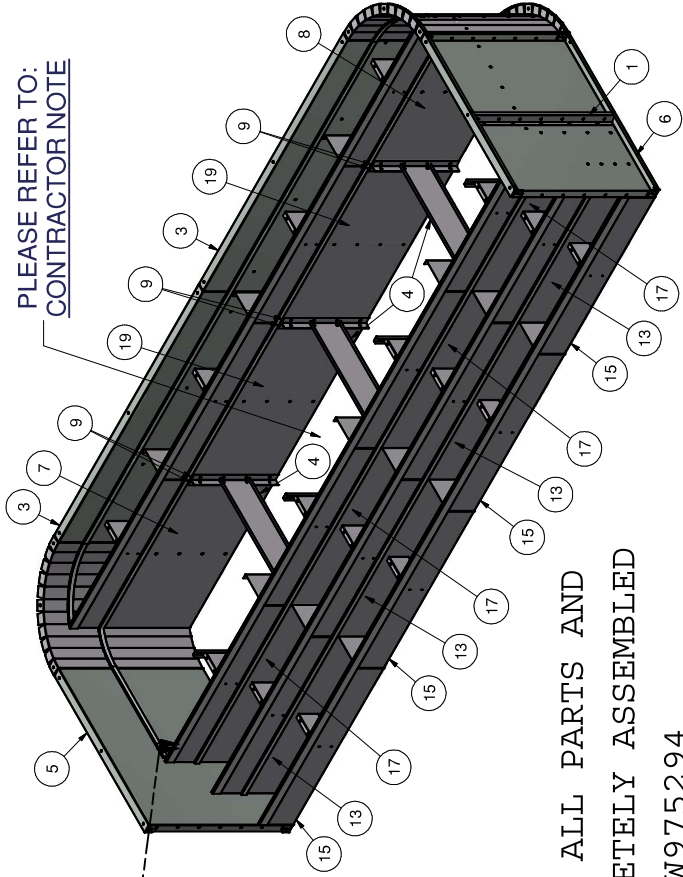

LABEL ALL PARTS AND COMPLETELY ASSEMBLED STEP W975294

CONTRACTOR MUST FIELD FIT ALL CONCRETE RECEPTOR TOTALS REQUIRED FOR THIS CUSTOM PRODUCT APPLICATION.
 OPC-CONREC-XX (NOTCHED) = 0" (0')
 OPC-CONREC-XXU (UN-NOTCHED) = 960" (80')
 COP-KCVRET-W-1 (STIFFENER) = 93

CONTRACTOR NOTE:

CONTRACTOR IS RESPONSIBLE FOR SECURING ALL RISERS INTO PLACE WITH REBAR HOLES BEFORE BACKFILLING THIS CUSTOM STEP

CONTRACTOR NOTE:

CONTRACTOR IS RESPONSIBLE FOR SECURING ALL BACK FILL STEP/SUNLEDGE AREA WITH COMPACTED EARTH MATERIAL. FINISH STEP/SUNLEDGE AREA WITH 2" OF HARDEN FLOOR MATERIAL TO MATCH REQUIRED DEPTH (FLUSH WITH TOP OF BEAD RECEIVER).

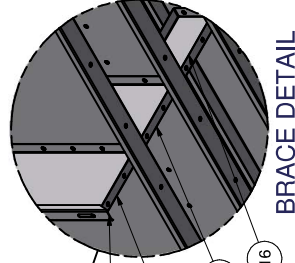

ITEM	QTY	PART NUMBER	DESCRIPTION
1	6	48-Z-RIB	
2	93	COP-KCVRET-W-1	COP COPING STIFFENER 1 5/8" x 1/4" PC
3	2	ESC-11271-BW	STRAIGHT, BACK WALL
4	3	ESC-11271-CB	BRACE, CENTER SUPPORT
5	1	ESC-11271-SWL	STRAIGHT, SIDE WALL, LEFT
6	1	ESC-11271-SWR	STRAIGHT, SIDE WALL, RIGHT
7	1	ESC-11271-TRL	STRAIGHT, TOP RISER, LEFT
8	1	ESC-11271-TRR	STRAIGHT, TOP RISER, RIGHT
9	6	ESC-6139-BB	BRACE, 90° L BRACKET
10	1	ESC-7033-CWL	RADIUS, CORNER WALL, LEFT
11	1	ESC-7033-CWR	RADIUS, CORNER WALL, RIGHT
12	3	ESC-8434-B	BRACE, 3-RISER SUPPORT
13	4	ESC-8434-BMR	STRAIGHT, BOTTOM MIDDLE RISER
14	4	ESC-8434-BMRS	BRACE, BOTTOM MIDDLE RISER SUPPORT
15	4	ESC-8434-BR	STRAIGHT, BOTTOM RISER
16	4	ESC-8434-BRS	BRACE, BOTTOM RISER SUPPORT
17	4	ESC-8434-TMR	STRAIGHT, TOP MIDDLE RISER
18	4	ESC-8434-TMRS	BRACE, TOP MIDDLE RISER SUPPORT
19	2	ESC-8434-TR	STRAIGHT, TOP RISER
20	3	ESC-8434-TRB	BRACE, TOP RISER
21	4	ESC-8434-TRS	BRACE, TOP RISER SUPPORT
22	4	ESC-9367-DS	BRACE, DRIVE STAKE CHANNEL SET
23	0'	OPC-CONREC-XX	NOTCHED CONCRETE RECEPTOR
24	80'	OPC-CONREC-XXU	UN-NOTCHED CONCRETE RECEPTOR
25	88'	SSC-1099-PPT	STEEL STEP PVC BEAD RETAINER (PER FT.)

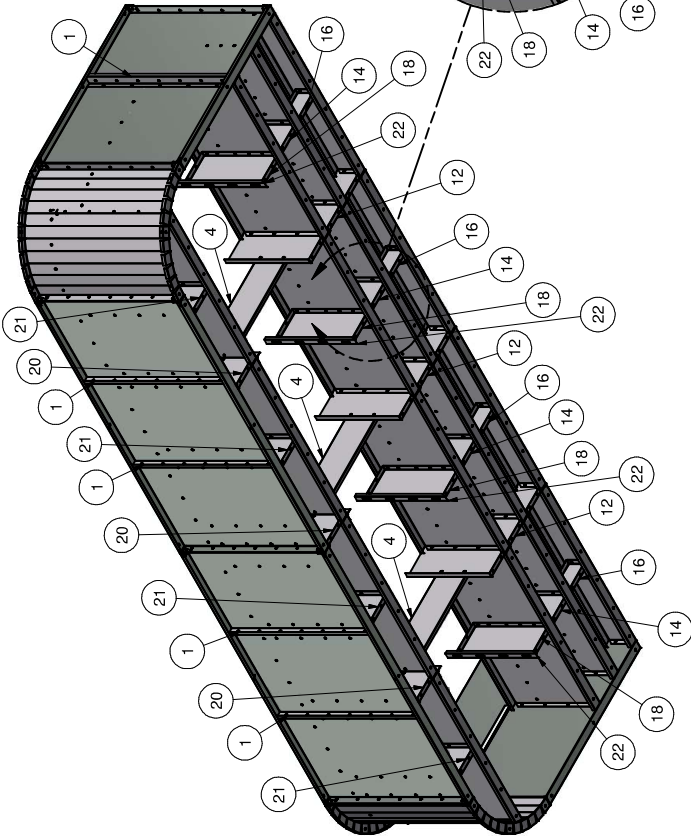

20' X 7' X 2'R CRN OPEN TOP STEP W/ 4' MIDDLE TREAD

PART #: ESC-11271

WEIGHT: 1371.68 lbmass

MACHINE TIME: N/A

FILE/DIRECTORY: C:\Vault\FTWDesign\CUSTOM STEPS\ESC-11000-11999\ESC-11271.idw



MATERIAL:

DATE: 10/1/2020

NOTES:

W975294, SO 5426661
PO# CQ209180

DRAWN BY: SUS

SHEET: 1 OF 21

NOTE:
RIGHT AND LEFT SIDE
PARTS ARE SYMMETRICAL.

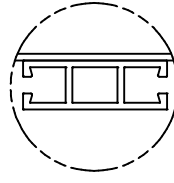
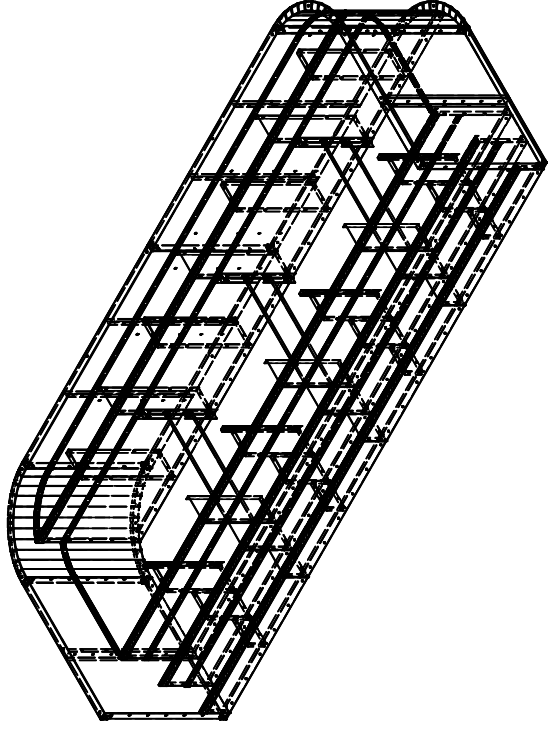
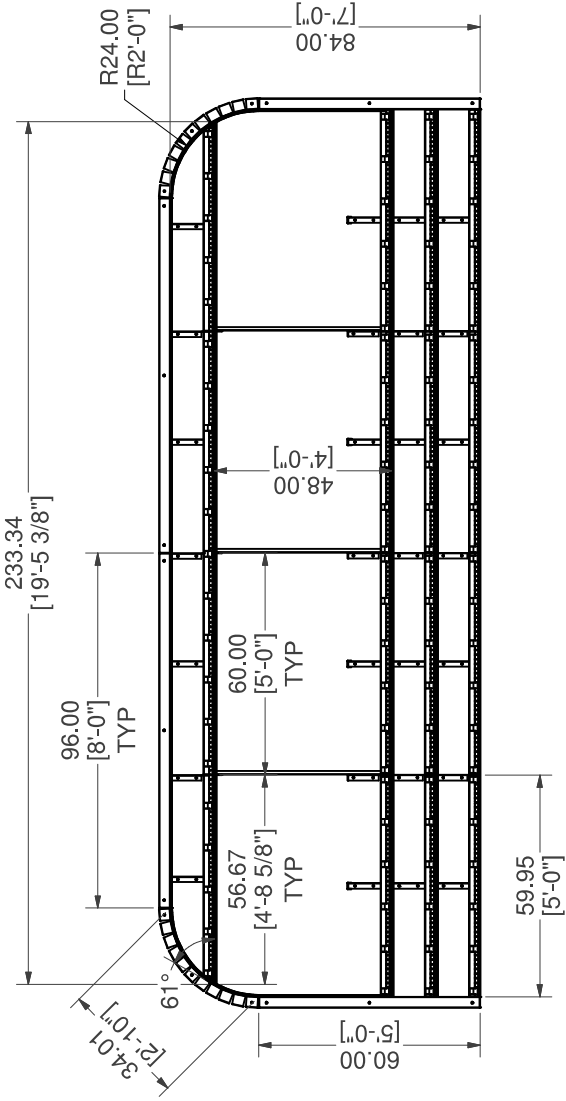

BEAD
RECEIVER
DETAIL

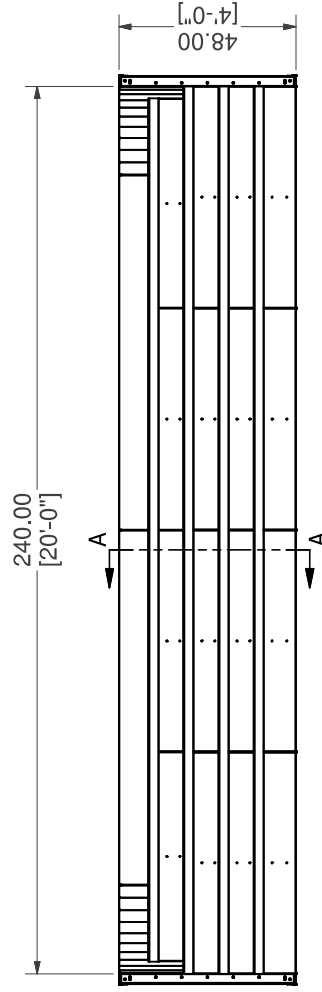
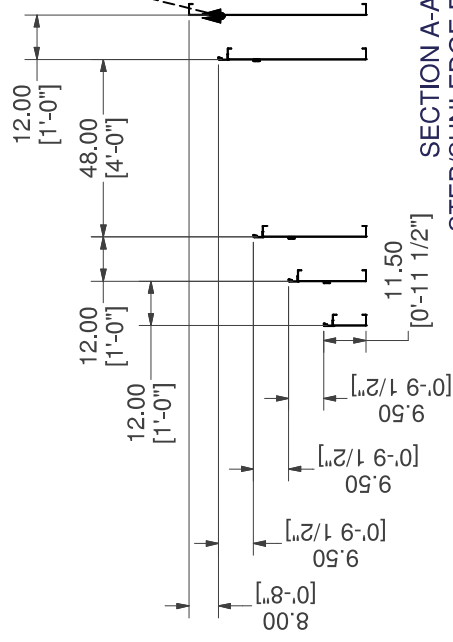

20' X 7' X 2'R CRN OPEN TOP STEP W/ 4' MIDDLE TREAD

PART #: ESC-11271

WEIGHT: 1371.68 lbmass
TOLERANCES EXCEPT
AS NOTED
0/0 0/0 0.00 0.000 0'
±1/8 ±0.25 ±0.0625 ±0.03125 ±1/2"

MACHINE TIME: N/A



MATERIAL:

DRAWN BY: SUS

DATE: 10/1/2020

SHEET: 2 OF 21

NOTES:

C:\Vault\FTWDesign\CUSTOM STEPS\ESC-11000-11999\ESC-11271.idw

SECTION A-A
STEP/SUNLEDGE DETAIL

Parts List		
ITEM	QTY	PART NUMBER DESCRIPTION
1	2	48-Z-RIB 48" Z-RIB
2	1	ESC-11271-BW STRAIGHT, BACK WALL

WELDCODE #71

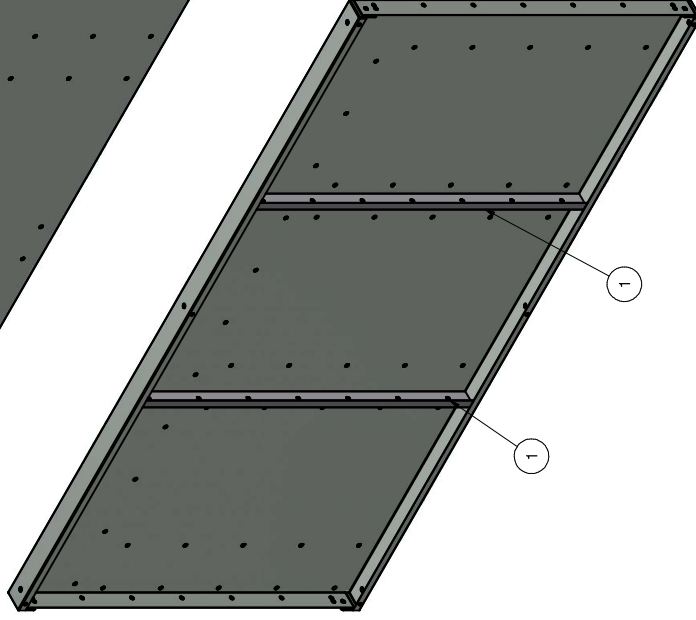
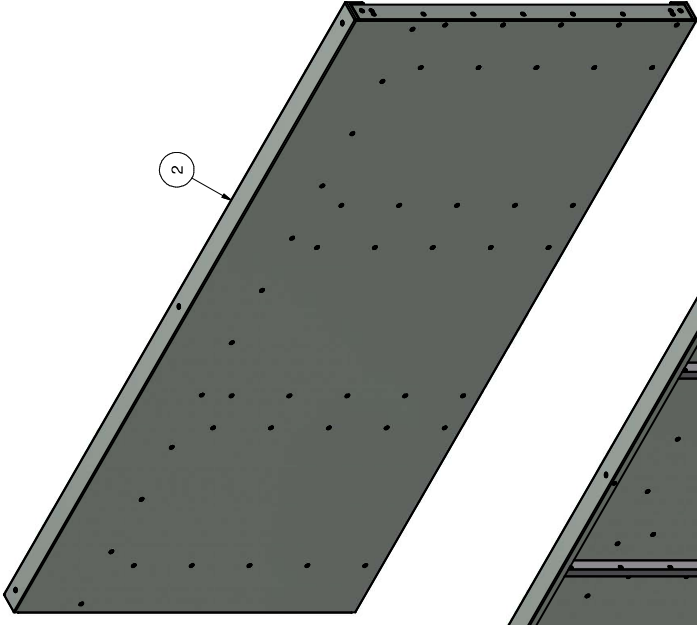
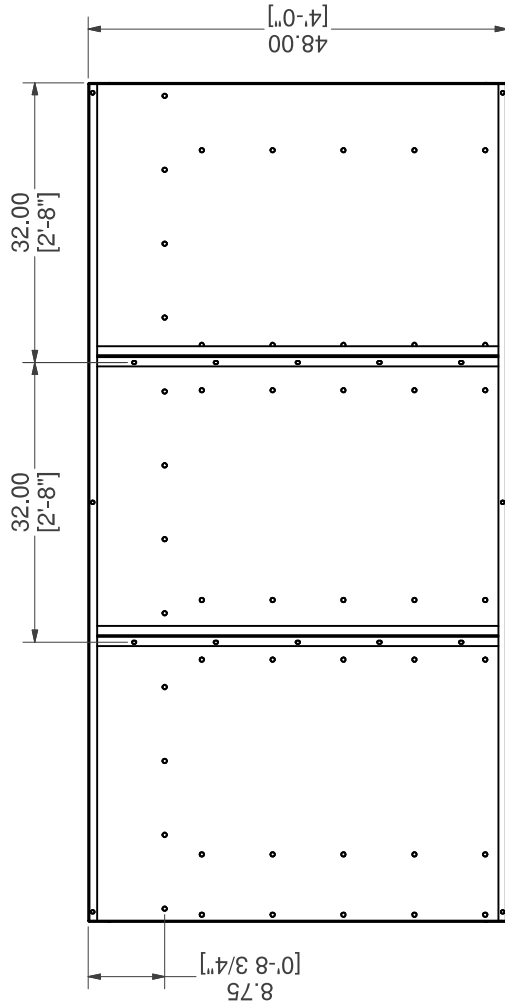
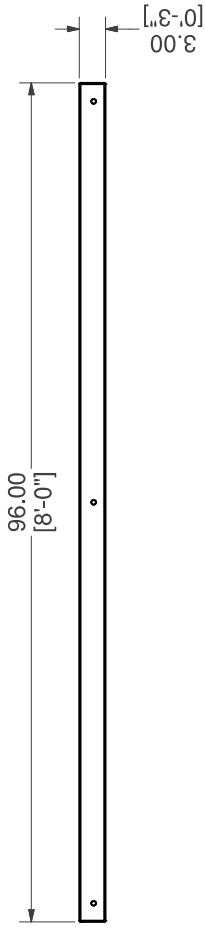

STRAIGHT, BACK WALL W/Z-RIB

PART #: ESC-11271-BW	WEIGHT: 122.03 lbmass	MACHINE TIME: N/A	FILE/DIRECTORY: C:\Vault\FTW\Design\CUSTOM STEPS\ESC-11000-11999\ESC-11271.idw
	TOLERANCES EXCEPT AS NOTED:	MATERIAL:	NOTES:
	0/0 0.0 0.00 0.000 0' ±1/8 ±0.25 ±0.0625 ±0.03125 ±1/2"	DRAWN BY: SUS	DATE: 10/1/2020
		SHEET: 3 OF 21	

Parts List		
ITEM	QTY	PART NUMBER DESCRIPTION
1	1	48-Z-RIB 48" Z-RIB
2	1	ESC-11271-SWL STRAIGHT, SIDE WALL, LEFT

WELDCODE #21

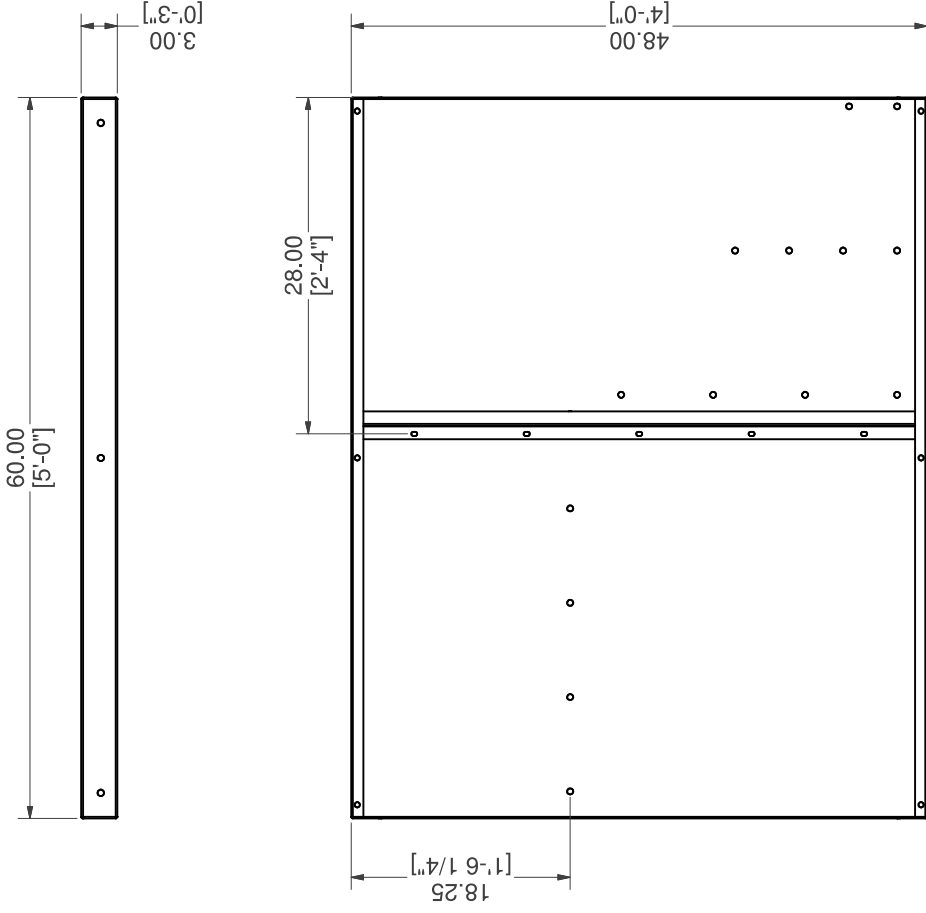

NOTE:
RIGHT SIDE PART IS SYMMETRICAL TO LEFT SIDE PART SHOWN.

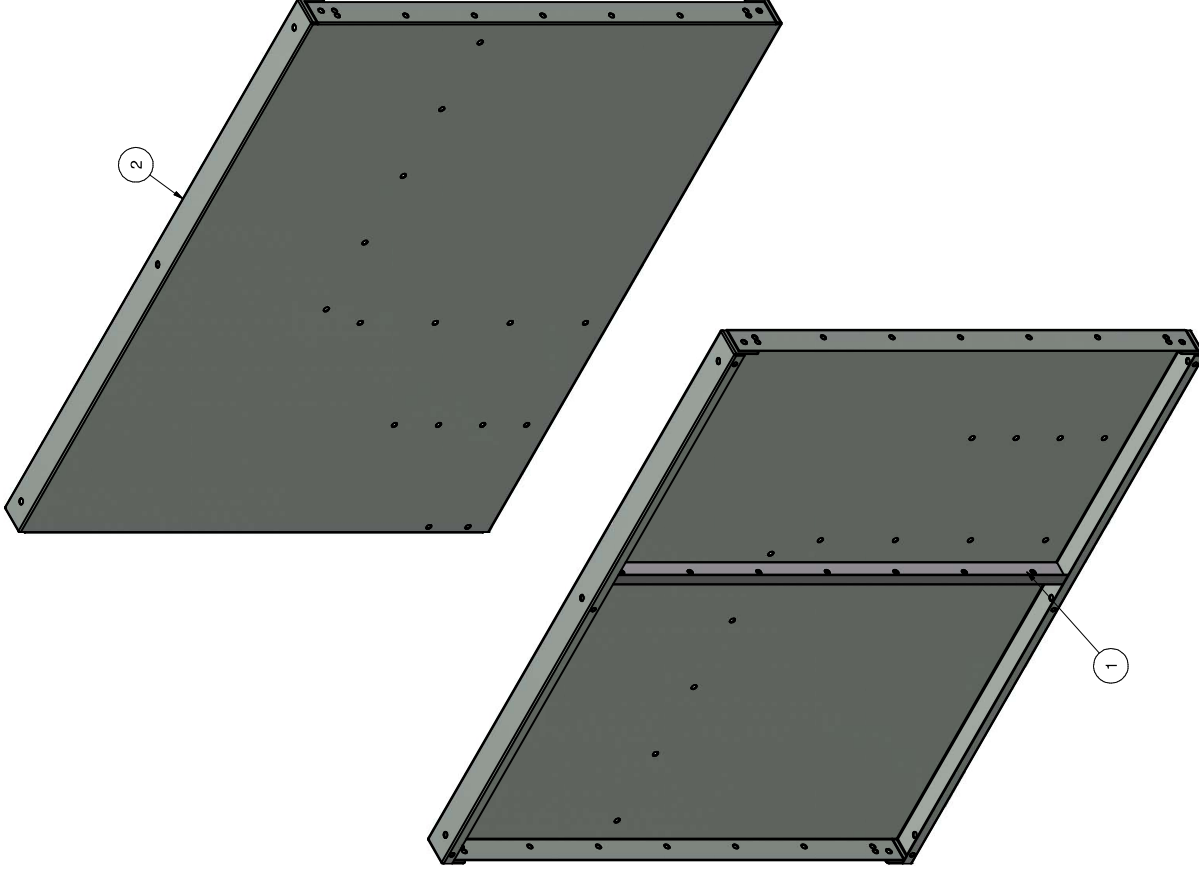

STRAIGHT, SIDE WALL, LEFT W/Z-RIB

PART #: ESC-11271-SWL	WEIGHT: 76.84 lbmass	MACHINE TIME: N/A	FILE/DIRECTORY: C:\Vault\FTWDesign\CUSTOM STEPS\ESC-11000-11999\ESC-11271.idw
	TOLERANCES EXCEPT AS NOTED	MATERIAL:	NOTES:
	0/0 0.0 0.00 0.000 0' ±1/8 ±0.25 ±0.0625 ±0.03125 ±1/2"	0/0 0.0 0.00 0.000 0' ±1/8 ±0.25 ±0.0625 ±0.03125 ±1/2"	DRAWN BY: SUS
		DATE: 10/1/2020	
		SHEET: 4 OF 21	

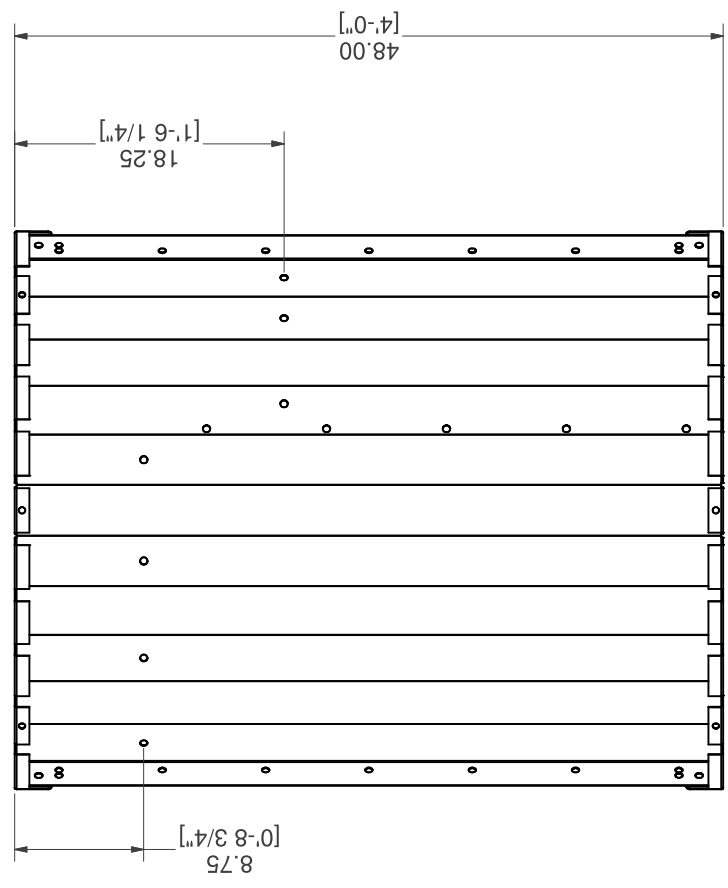
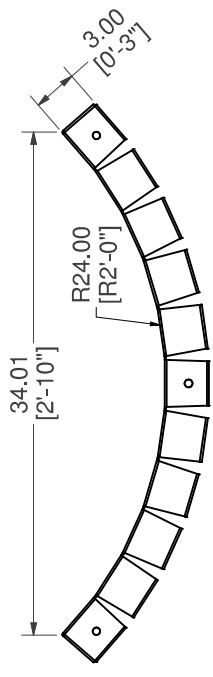
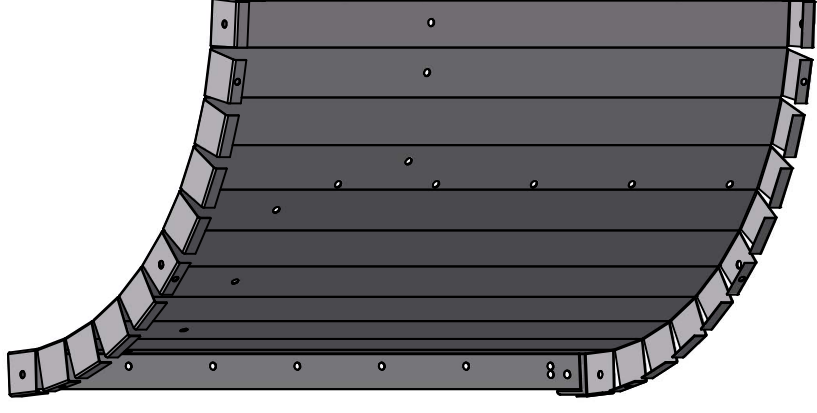

NOTE:
RIGHT SIDE PART IS SYMMETRICAL TO LEFT SIDE PART SHOWN.

RADIUS, CORNER WALL, LEFT

PART #: ESC-7033-CWL	WEIGHT: 46.49 lbmass	MACHINE TIME: N/A	FILE/DIRECTORY: C:\Vault\FTWDesign\CUSTOM STEPS\ESC-11000-11999\ESC-11271.idw
TOLERANCES EXCEPT AS NOTED	MATERIAL: 14 GA. GALVANIZED	DATE: 10/1/2020	NOTES:
0/0 0.0 0.00 0.000 0'	DRAWN BY: SUS	SHEET: 5 OF 21	
±1/8 ±0.25 ±0.0625 ±0.03125 ±1/2'			



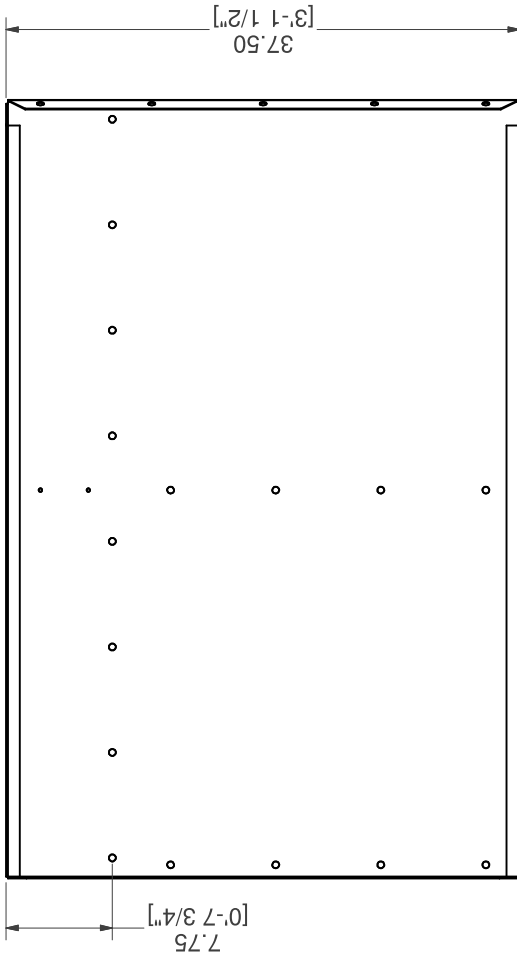
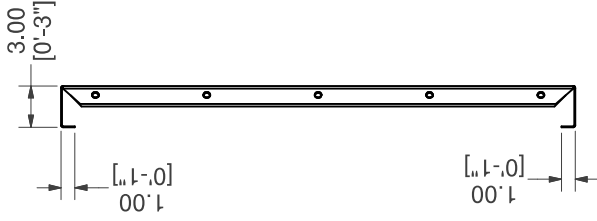
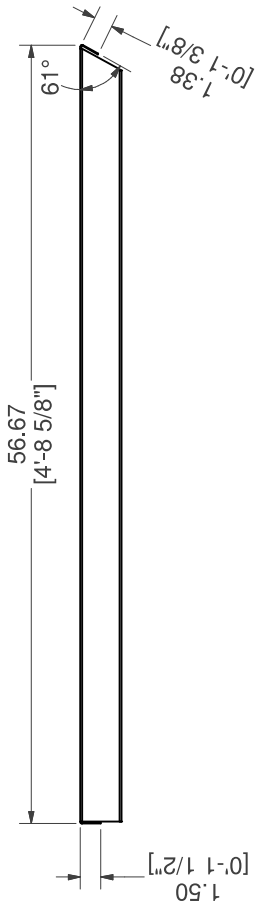
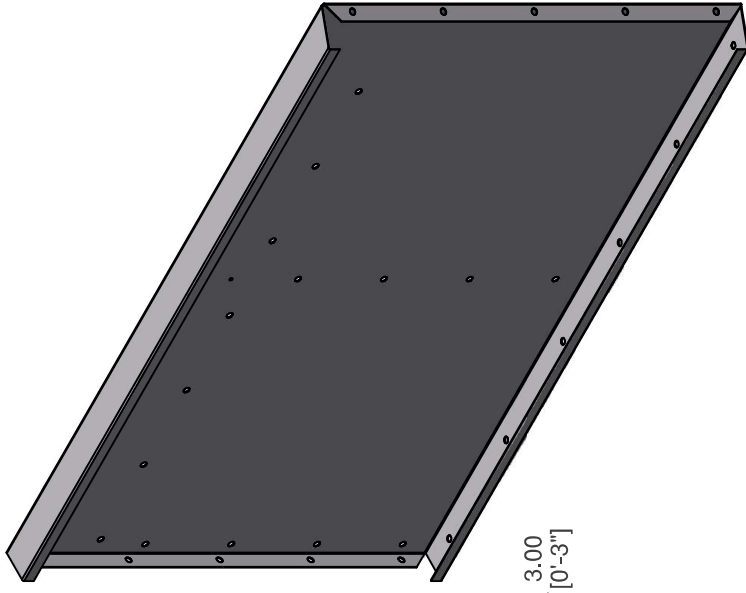

NOTE:
RIGHT SIDE PART IS SYMMETRICAL TO LEFT SIDE PART SHOWN.

STRAIGHT, TOP RISER, LEFT

PART #: ESC-11271-TRL	WEIGHT: 53.52 lbmass	MACHINE TIME: N/A	FILE/DIRECTORY: C:\Vault\FTWDesign\CUSTOM STEPS\ESC-11000-11999\ESC-11271.idw
	TOLERANCES EXCEPT AS NOTED	MATERIAL: 14 GA. GALVANIZED	DATE: 10/1/2020
	0/0 0.0 0.00 0.000 0' ±1/8 ±0.25 ±0.0625 ±0.03125 ±1/2"	DRAWN BY: SUS	SHEET: 6 OF 21

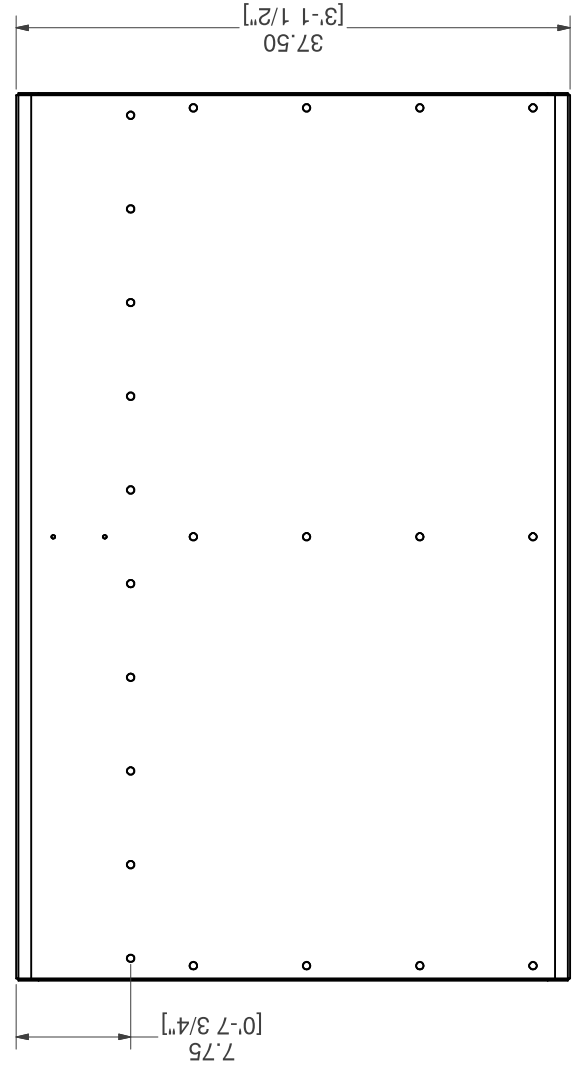
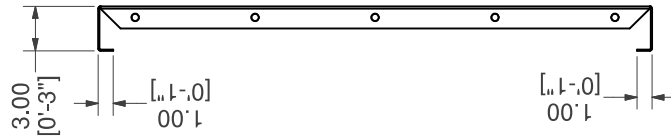
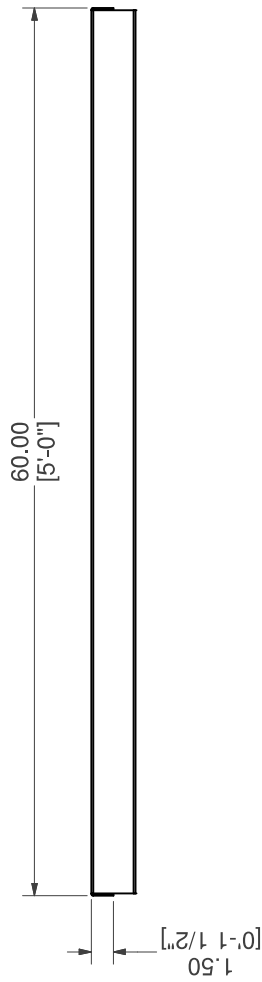
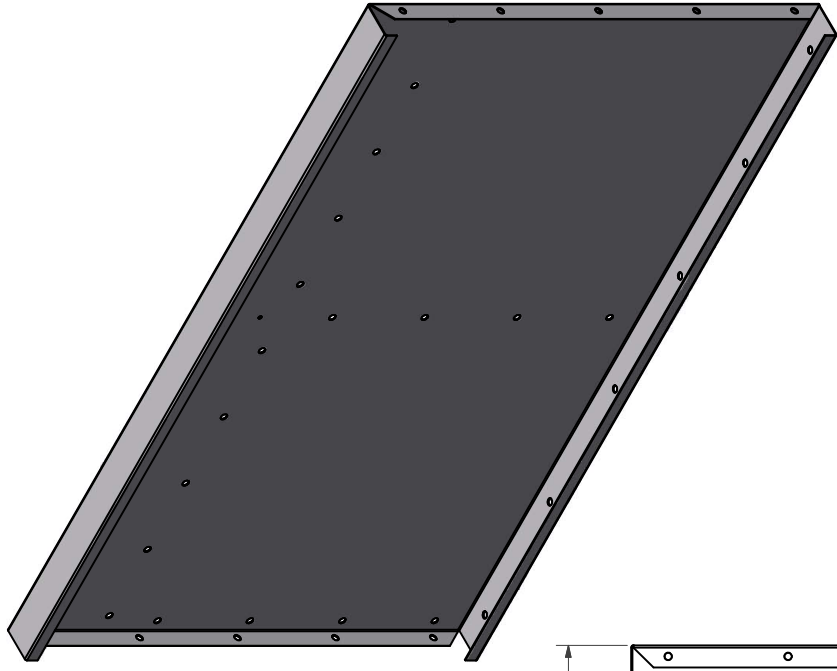

STRAIGHT, TOP RISER

PART #: ESC-8434-TR **WEIGHT:** 56.73 lbmass
MACHINE TIME: N/A **FILE/DIRECTORY:** C:\Vault\FTWDesign\CUSTOM STEPS\ESC-11000-11999\ESC-11271.idw

NOTES:

DATE: 10/1/2020
SHEET: 7 OF 21

MATERIAL: 14 GA. GALVANIZED
DRAWN BY: SUS

TOLERANCES EXCEPT AS NOTED:
 0/0 0.0 0.00 0.000 0'
 ±1/8 ±0.25 ±0.0625 ±0.03125 ±1/2"



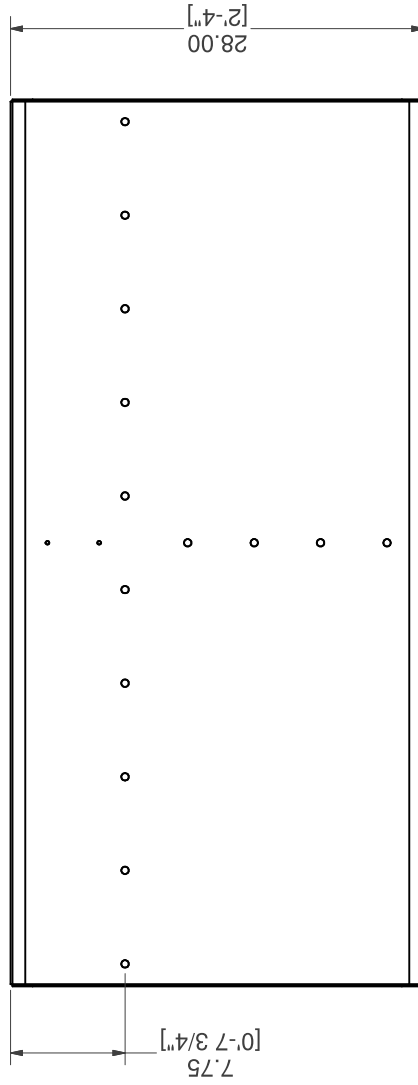
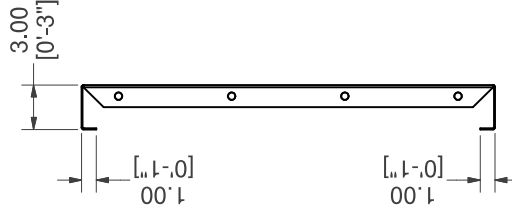
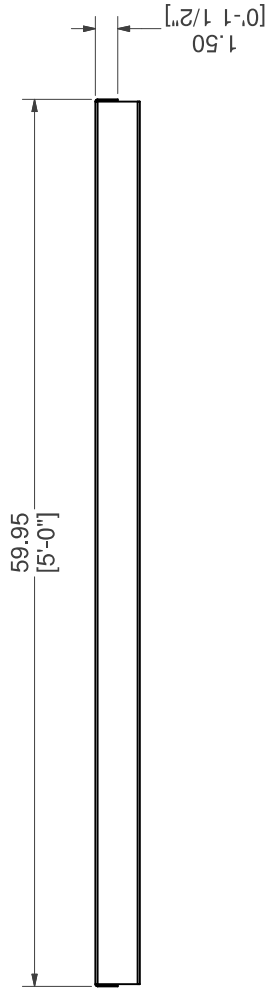
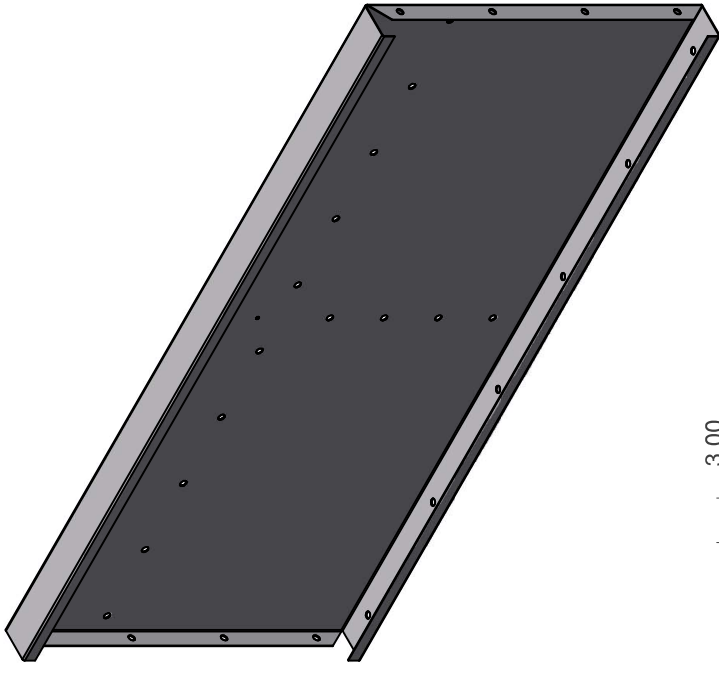

STRAIGHT, TOP MIDDLE RISER

PART #: ESC-8434-TMR	WEIGHT: 44.61 lbmass	MACHINE TIME: N/A	FILE/DIRECTORY: C:\Vault\FTWDesign\CUSTOM STEPS\ESC-11000-11999\ESC-11271.idw
LATHAM <i>behind every pool</i>	TOLERANCES EXCEPT AS NOTED	MATERIAL: 14 GA. GALVANIZED	DATE: 10/1/2020
	0/0 0.0 0.00 0.000 0° ±1/8 ±0.25 ±0.0625 ±0.03125 ±1/2"	DRAWN BY: SUS	SHEET: 8 OF 21

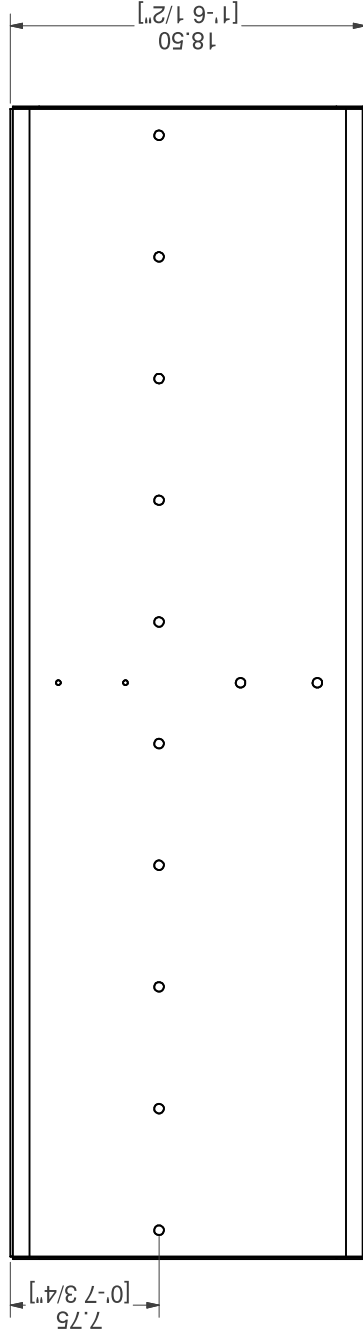
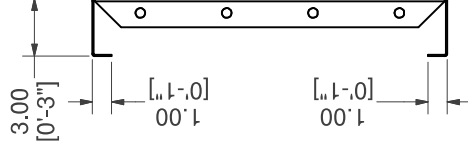
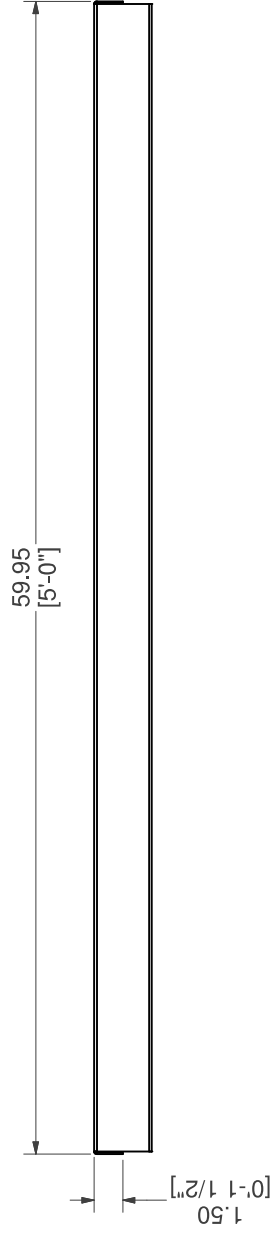
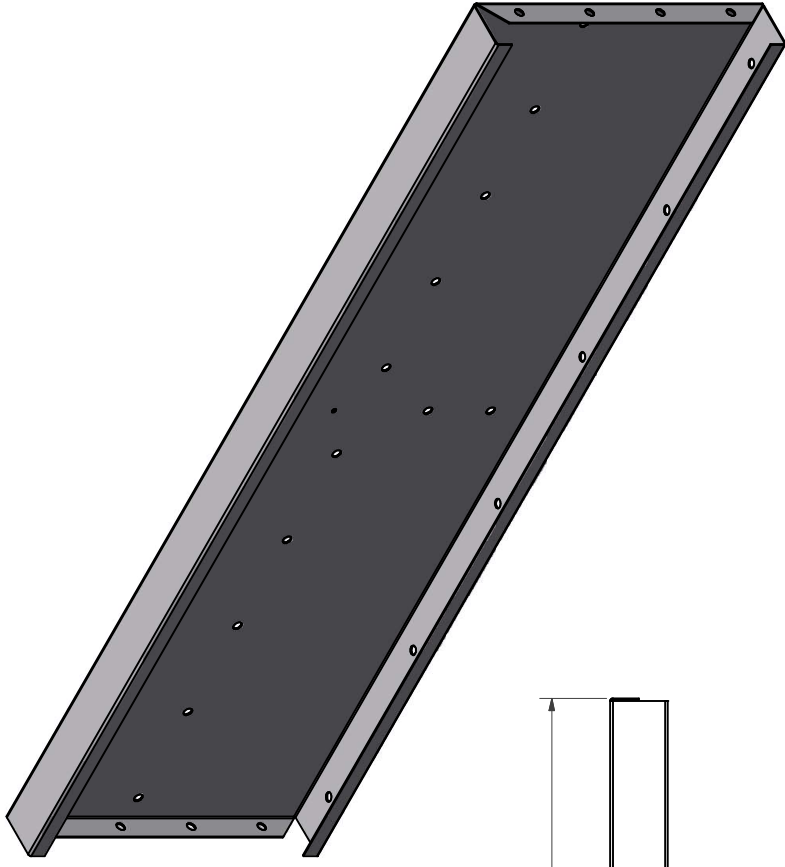

STRAIGHT, BOTTOM MIDDLE RISER

PART #: ESC-8434-BMR	WEIGHT: 32.52 lbmass	MACHINE TIME: N/A	FILE/DIRECTORY: C:\Vault\FTWDesign\CUSTOM STEPS\ESC-11000-11999\ESC-11271.idw
LATHAM <i>behind every pool</i>	TOLERANCES EXCEPT AS NOTED	MATERIAL: 14 GA. GALVANIZED	DATE: 10/1/2020
	0/0 0.0 0.00 0.000 0° ±1/8 ±0.25 ±0.0625 ±0.03125 ±1/2"	DRAWN BY: SUS	NOTES:

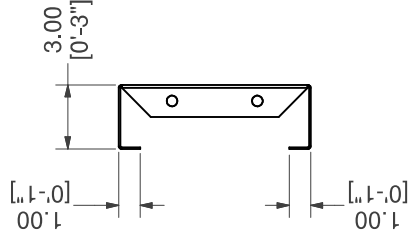
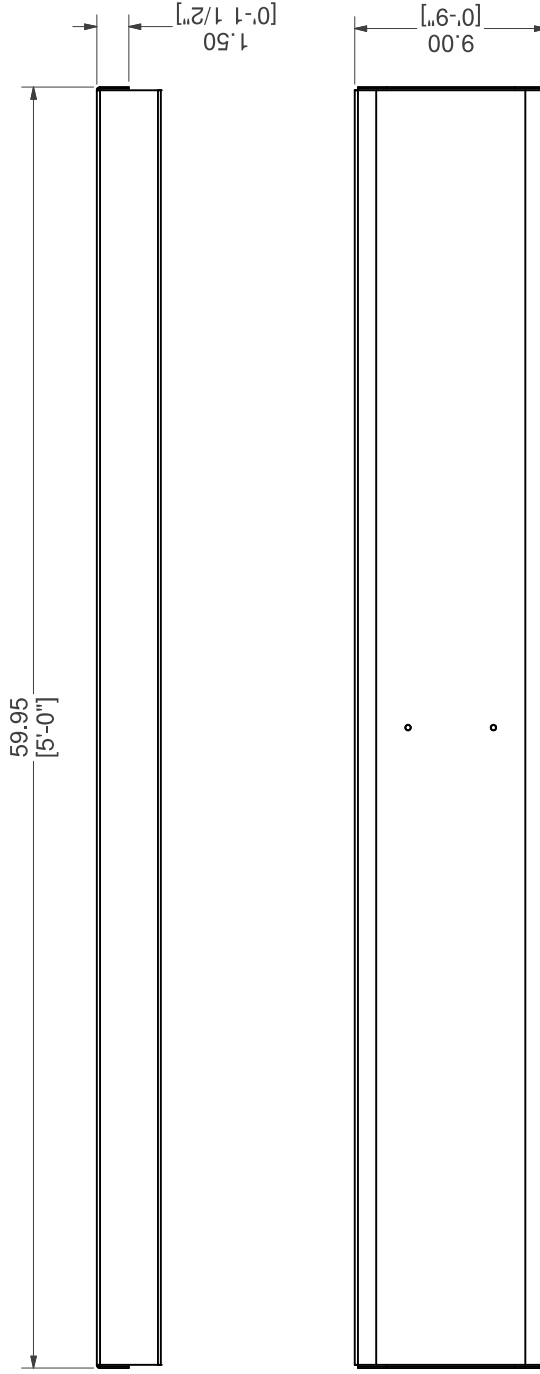
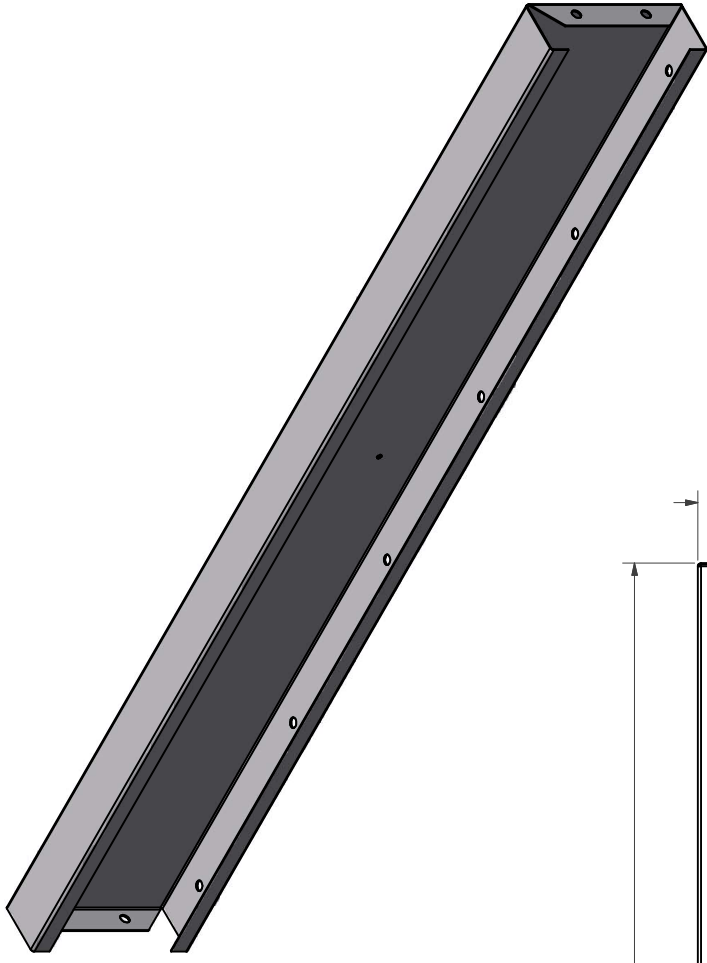

STRAIGHT, BOTTOM RISER

PART #: ESC-8434-BR	WEIGHT: 20.47 lbmass	MACHINE TIME: N/A	FILE/DIRECTORY: C:\Vault\FTWDesign\CUSTOM STEPS\ESC-11000-11999\ESC-11271.idw
TOLERANCES EXCEPT AS NOTED 0/0 0.0 0.00 0.000 0' ±1/8 ±0.25 ±0.0625 ±0.03125 ±1/2"	MATERIAL: 14 GA. GALVANIZED	DATE: 10/1/2020	NOTES:
	DRAWN BY: SUS	SHEET: 10 OF 21	



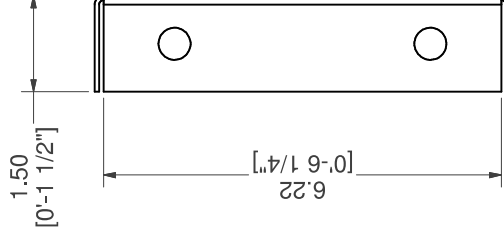
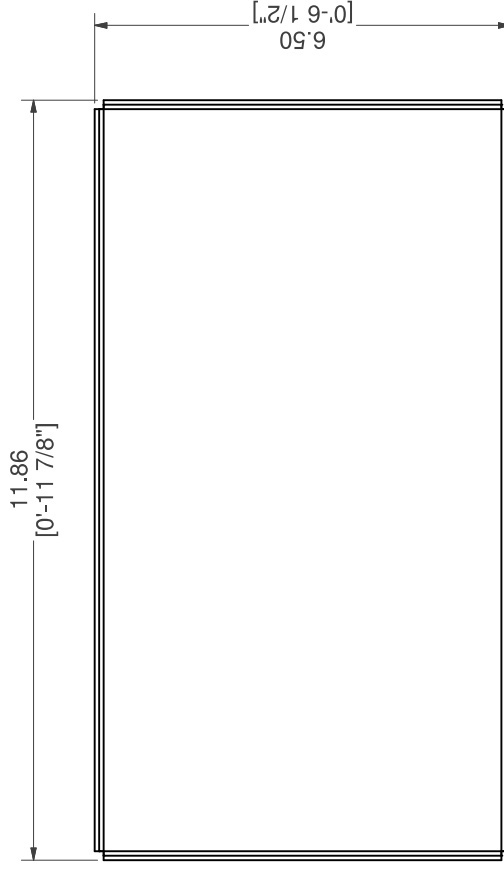
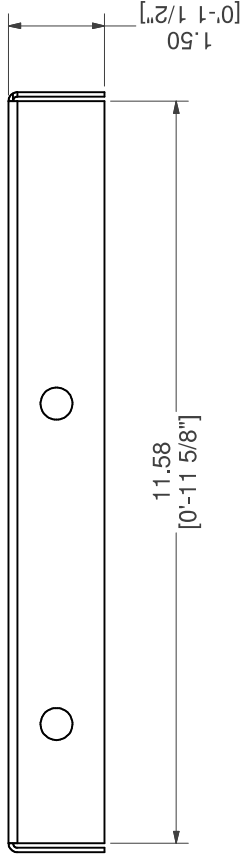
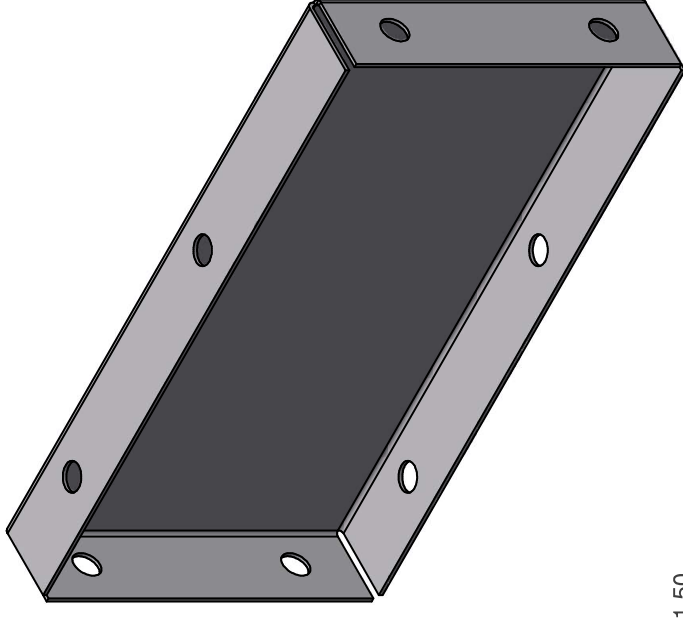

BRACE, BOTTOM RISER SUPPORT

PART #: ESC-8434-BRS	WEIGHT: 2.53 lbmass	MACHINE TIME: N/A	FILE/DIRECTORY: C:\Vault\FTWDesign\CUSTOM STEPS\ESC-11000-11999\ESC-11271.idw
	TOLERANCES EXCEPT AS NOTED	MATERIAL: 14 GA. GALVANIZED	DATE: 10/1/2020
	0/0 0.0 0.00 0.000 0° ±1/8 ±0.25 ±0.0625 ±0.03125 ±1/2"	DRAWN BY: SUS	SHEET: 11 OF 21

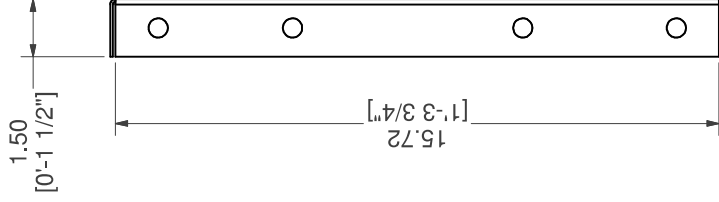
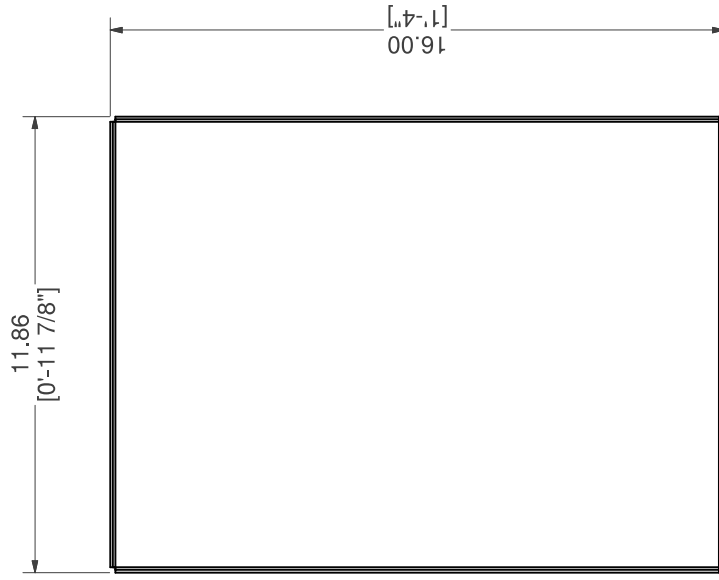
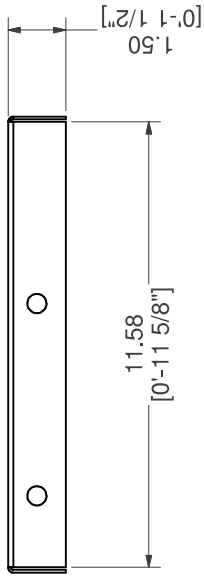
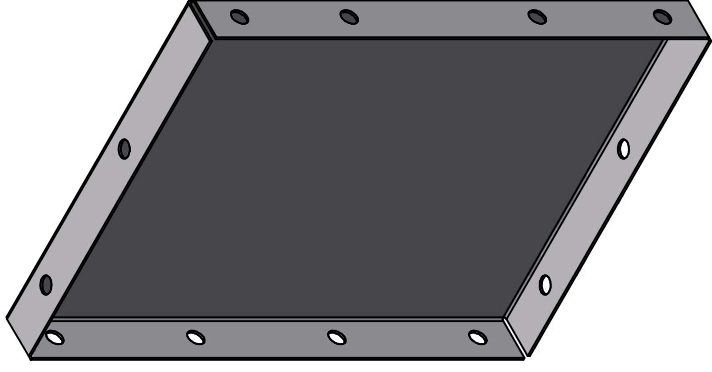

BRACE, BOTTOM MIDDLE RISER SUPPORT

PART #: ESC-8434-BMRS	WEIGHT: 5.34 lbmass	MACHINE TIME: N/A	FILE/DIRECTORY: C:\Vault\FTWDesign\CUSTOM STEPS\ESC-11000-11999\ESC-11271.idw
LATHAM <i>behind every pool</i>	TOLERANCES EXCEPT AS NOTED	MATERIAL: 14 GA. GALVANIZED	DATE: 10/1/2020
	0/0 0.0 0.00 0.000 0° ±1/8 ±0.25 ±0.0625 ±0.03125 ±1/2"	DRAWN BY: SUS	SHEET: 12 OF 21

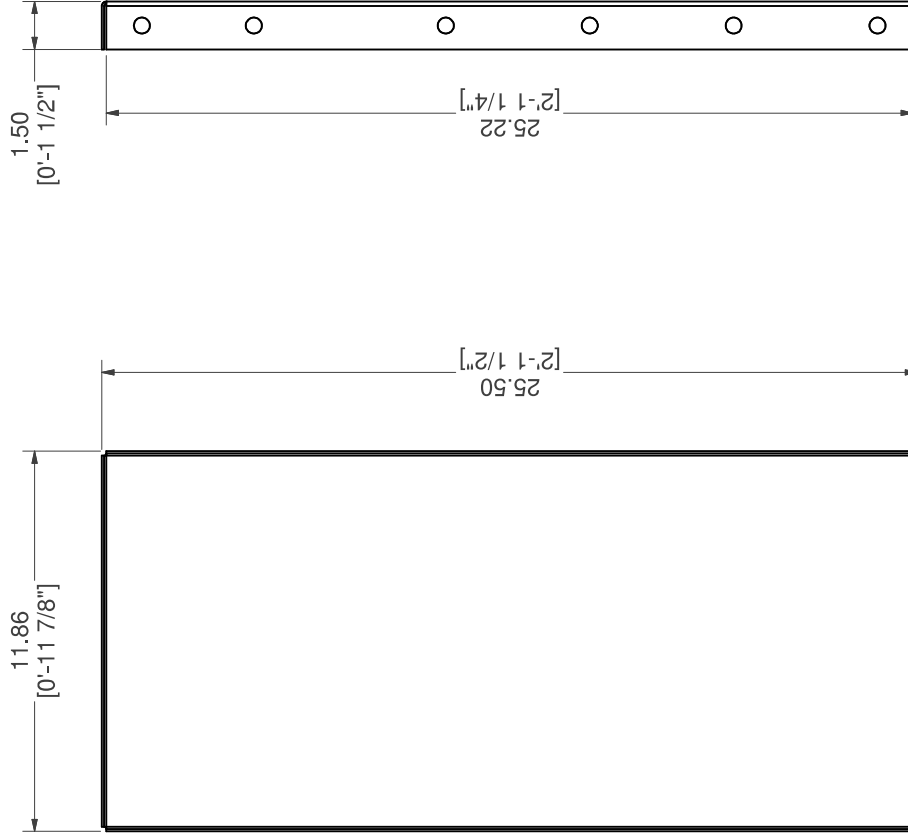
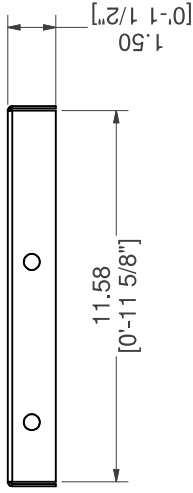
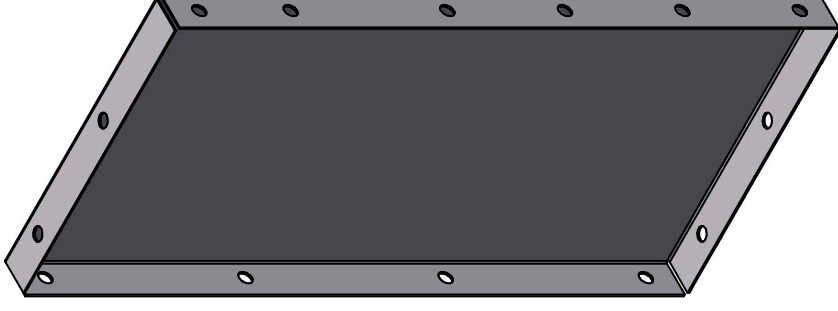

BRACE, TOP MIDDLE RISER SUPPORT

PART #: ESC-8434-TMRS

WEIGHT: 8.16 lbmass
TOLERANCES EXCEPT AS NOTED
0/0 0.0 0.00 0.000 0'
±1/8 ±0.25 ±0.0625 ±0.03125 ±1/2"

MACHINE TIME: N/A

FILE/DIRECTORY: C:\Vault\FTWDesign\CUSTOM STEPS\ESC-1000-11999\ESC-11271.idw



MATERIAL: 14 GA. GALVANIZED

DATE: 10/1/2020

DRAWN BY: SUS

SHEET: 13 OF 21

NOTES:

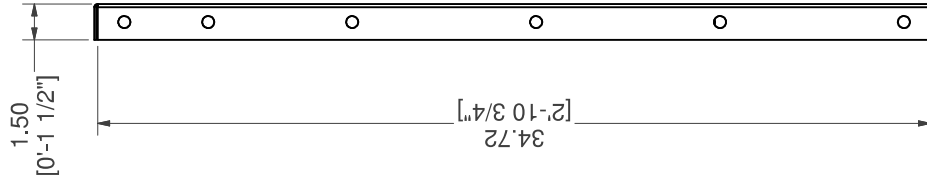
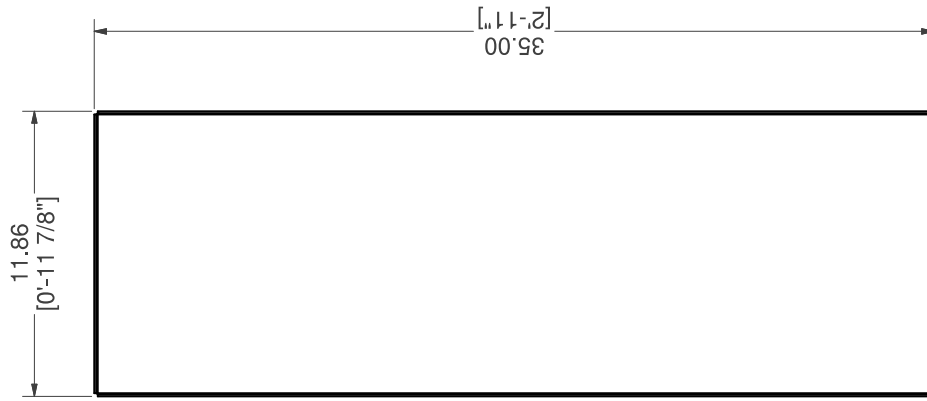
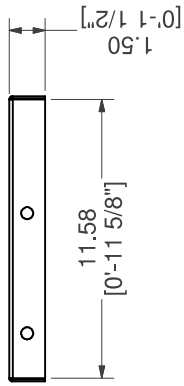
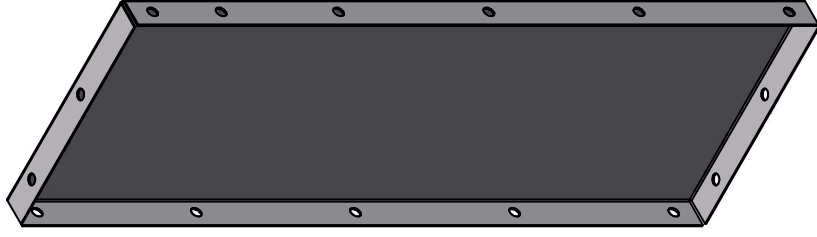

BRACE, TOP RISER SUPPORT

PART #: ESC-8434-TRS	WEIGHT: 10.98 lbmass	MACHINE TIME: N/A	FILE/DIRECTORY: C:\Vault\FTWDesign\CUSTOM STEPS\ESC-11000-11999\ESC-11271.idw
	TOLERANCES EXCEPT AS NOTED	MATERIAL: 14 GA. GALVANIZED	DATE: 10/1/2020
	0/0 0.0 0.00 0.000 0° ±1/8 ±0.25 ±0.0625 ±0.03125 ±1/2"	DRAWN BY: SUS	NOTES:
		SHEET: 14	OF 21

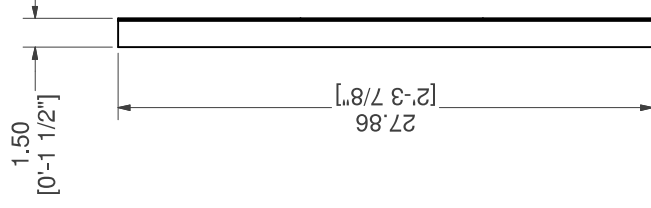
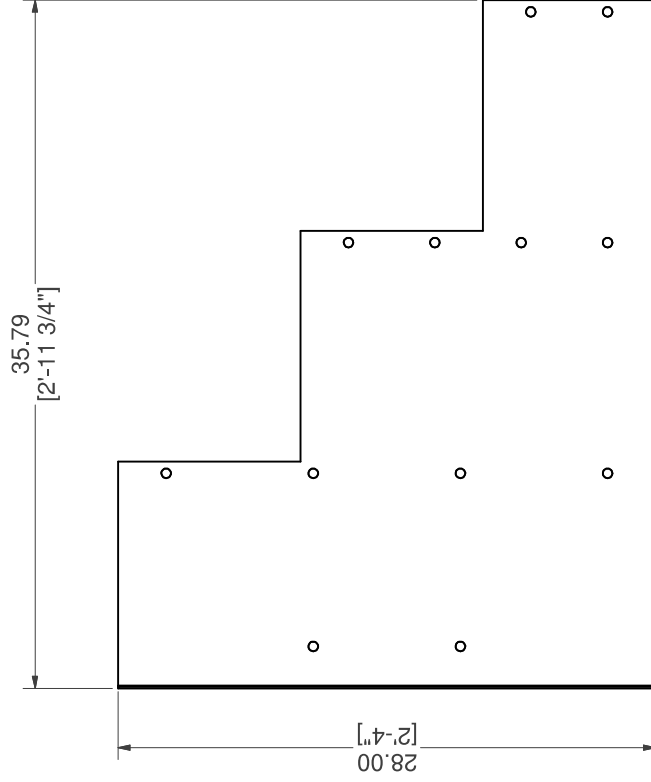
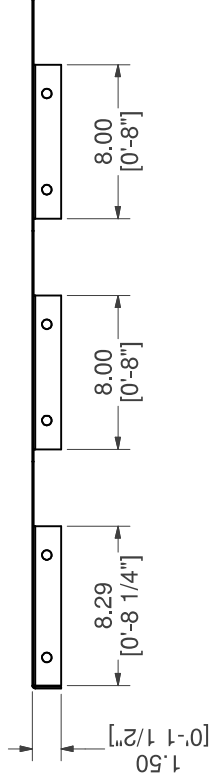
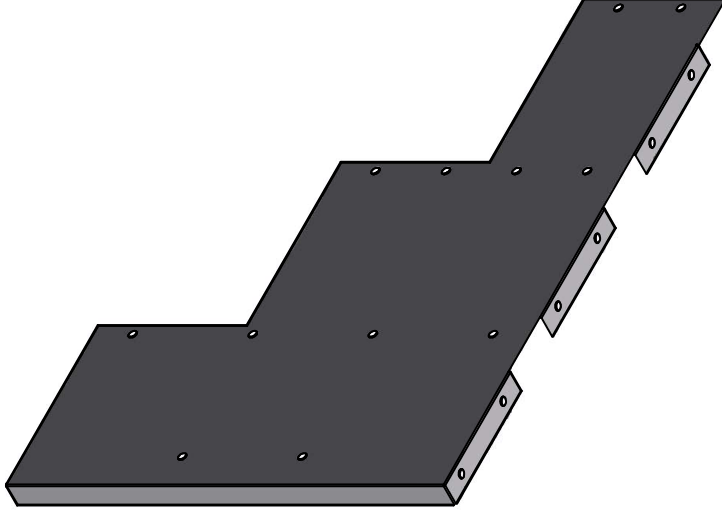

BRACE, 3-RISER SUPPORT

PART #: ESC-8434-B	WEIGHT: 14.78 lbmass	MACHINE TIME: N/A	FILE/DIRECTORY: C:\Vault\FTWDesign\CUSTOM STEPS\ESC-11000-11999\ESC-11271.idw
TOLERANCES EXCEPT AS NOTED 0/0 0.0 0.00 0.000 0' ±1/8 ±0.25 ±0.0625 ±0.03125 ±1/2"	MATERIAL: 14 GA. GALVANIZED	DATE : 10/1/2020	NOTES:
	DRAWN BY: SUS	SHEET : 15 OF 21	



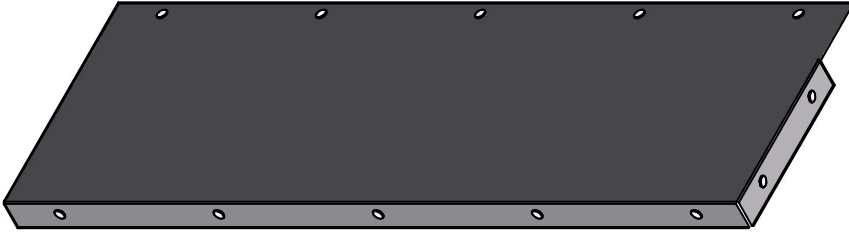
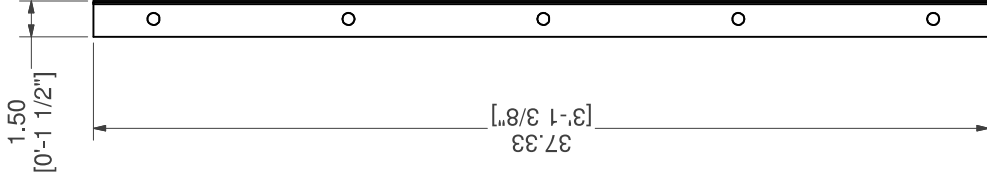
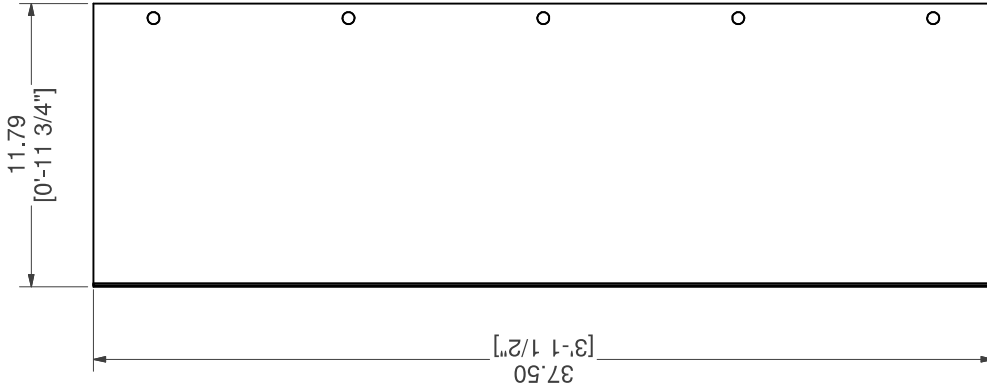
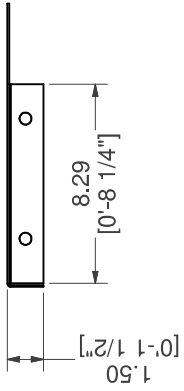



BRACE, TOP RISER

PART #: ESC-8434-TRB	WEIGHT: 10.22 lbmass	MACHINE TIME: N/A	FILE/DIRECTORY: C:\Vault\FTWDesign\CUSTOM STEPS\ESC-1000-11999\ESC-11271.idw
TOLERANCES EXCEPT AS NOTED 0/0 0.0 0.00 0.000 0' ±1/8 ±0.25 ±0.0625 ±0.03125 ±1/2'	MATERIAL: 14 GA. GALVANIZED	DATE: 10/1/2020	NOTES:
	DRAWN BY: SUS	SHEET: 16 OF 21	

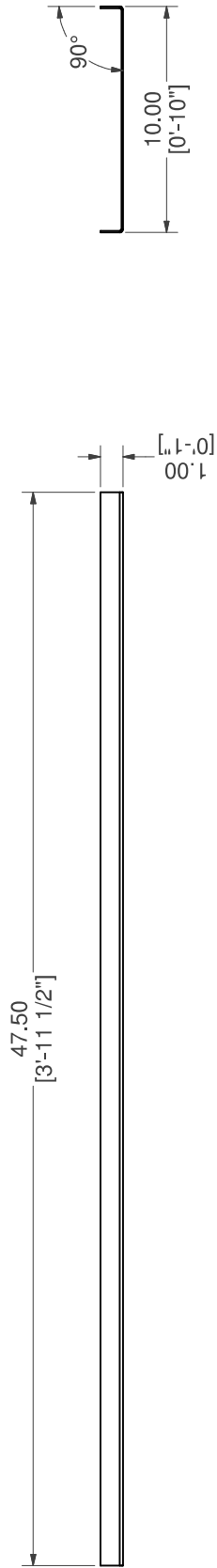
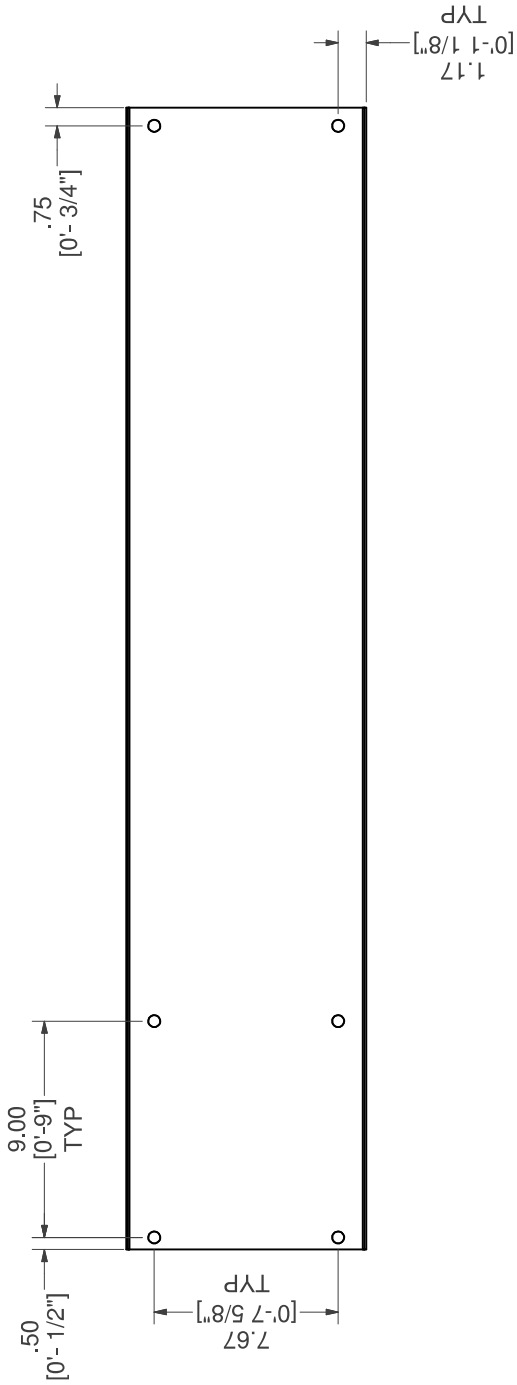
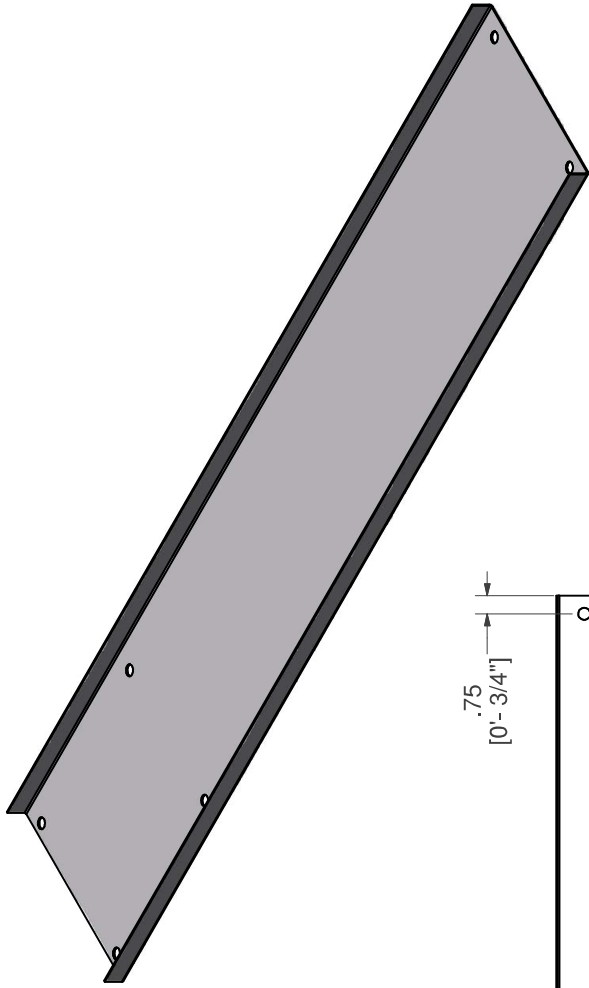



BRACE, CENTER SUPPORT

PART #: ESC-11271-CB	WEIGHT: 11.34 lbmass TOLERANCES EXCEPT AS NOTED 0/0 0.0 0.00 0.000 0' ±1/8 ±0.25 ±0.0625 ±0.03125 ±1/2"	MACHINE TIME: N/A	FILE/DIRECTORY: C:\Vault\FTWDesign\CUSTOM STEPS\ESC-11000-11999\ESC-11271.idw
	MATERIAL: 14 GA. GALVANIZED	DATE: 10/1/2020	NOTES:
	DRAWN BY: SUS	SHEET: 17 OF 21	

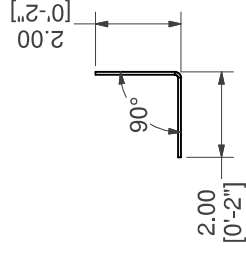
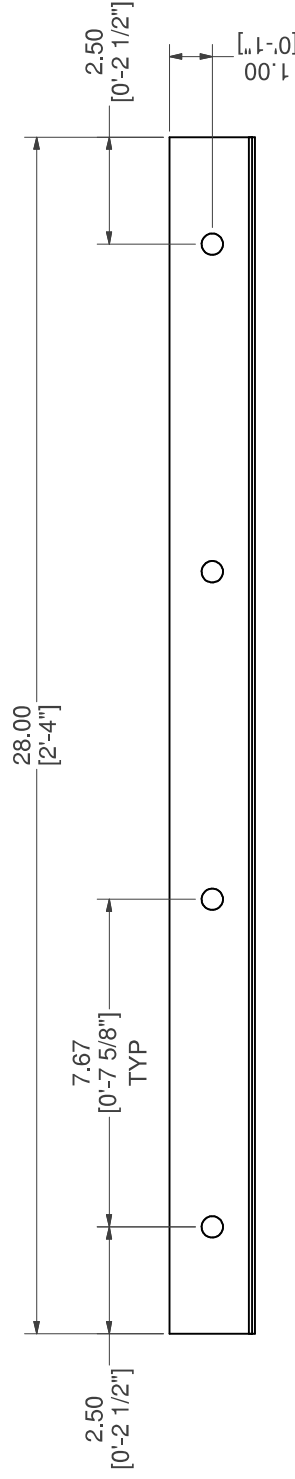
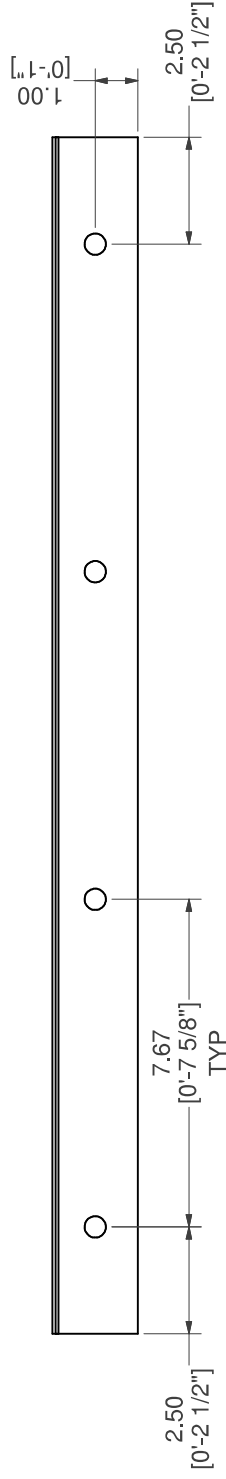
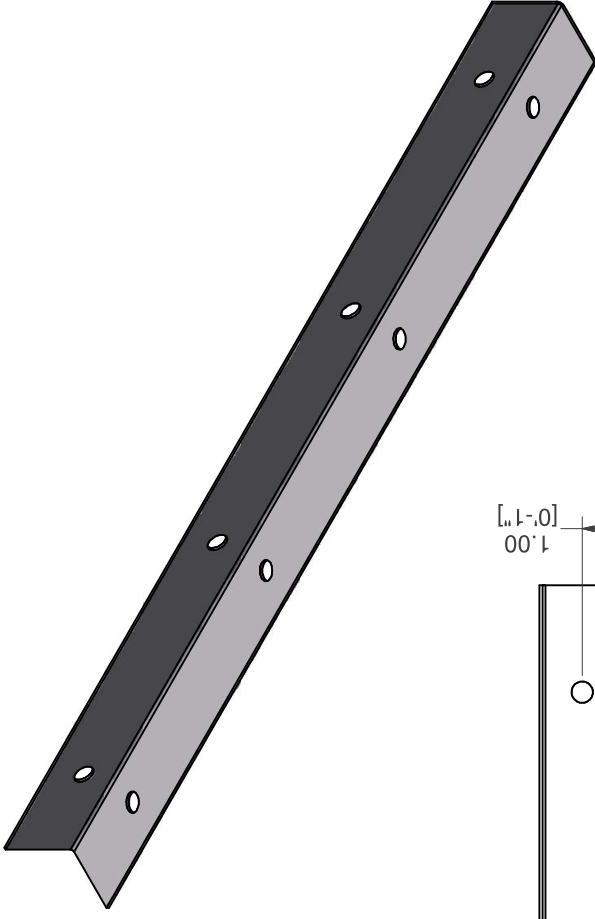

BRACE, 90° L BRACKET

PART #: ESC-6139-BB	WEIGHT: 2.18 lbmass	MACHINE TIME: N/A	FILE/DIRECTORY: C:\Vault\FTWDesign\CUSTOM STEPS\ESC-11000-11999\ESC-11271.idw
TOLERANCES EXCEPT AS NOTED 0/0 0.0 0.00 0.000 0° ±1/8 ±0.25 ±0.0625 ±0.03125 ±1/2"	MATERIAL: 14 GA. GALVANIZED	DATE: 10/1/2020	NOTES:
	DRAWN BY: SUS	SHEET: 18 OF 21	



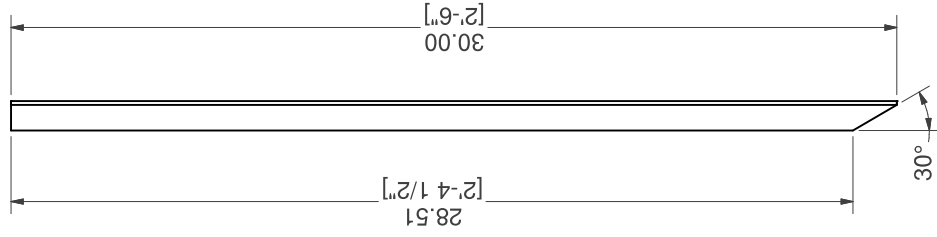
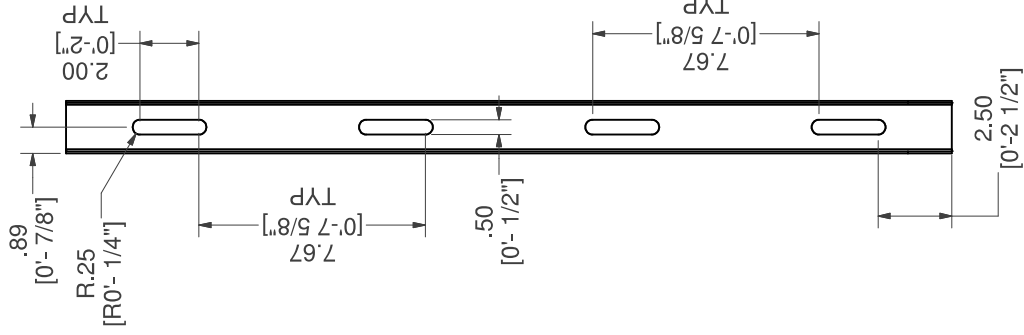
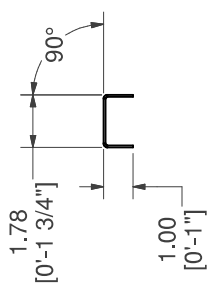

BRACE, DRIVE STAKE CHANNEL SET

PART #: ESC-9367-DS	WEIGHT: 2.04 lbmass	MACHINE TIME: N/A	FILE/DIRECTORY: C:\Vault\FTW\Design\CUSTOM STEPS\ESC-11000-11999\ESC-11271.idw
	TOLERANCES EXCEPT AS NOTED	MATERIAL: 14 GA. GALVANIZED	DATE: 10/1/2020
	0/0 0.0 0.00 0.000 0' ±1/8 ±0.25 ±0.0625 ±0.03125 ±1/2"	DRAWN BY: SUS	SHEET: 19 OF 21

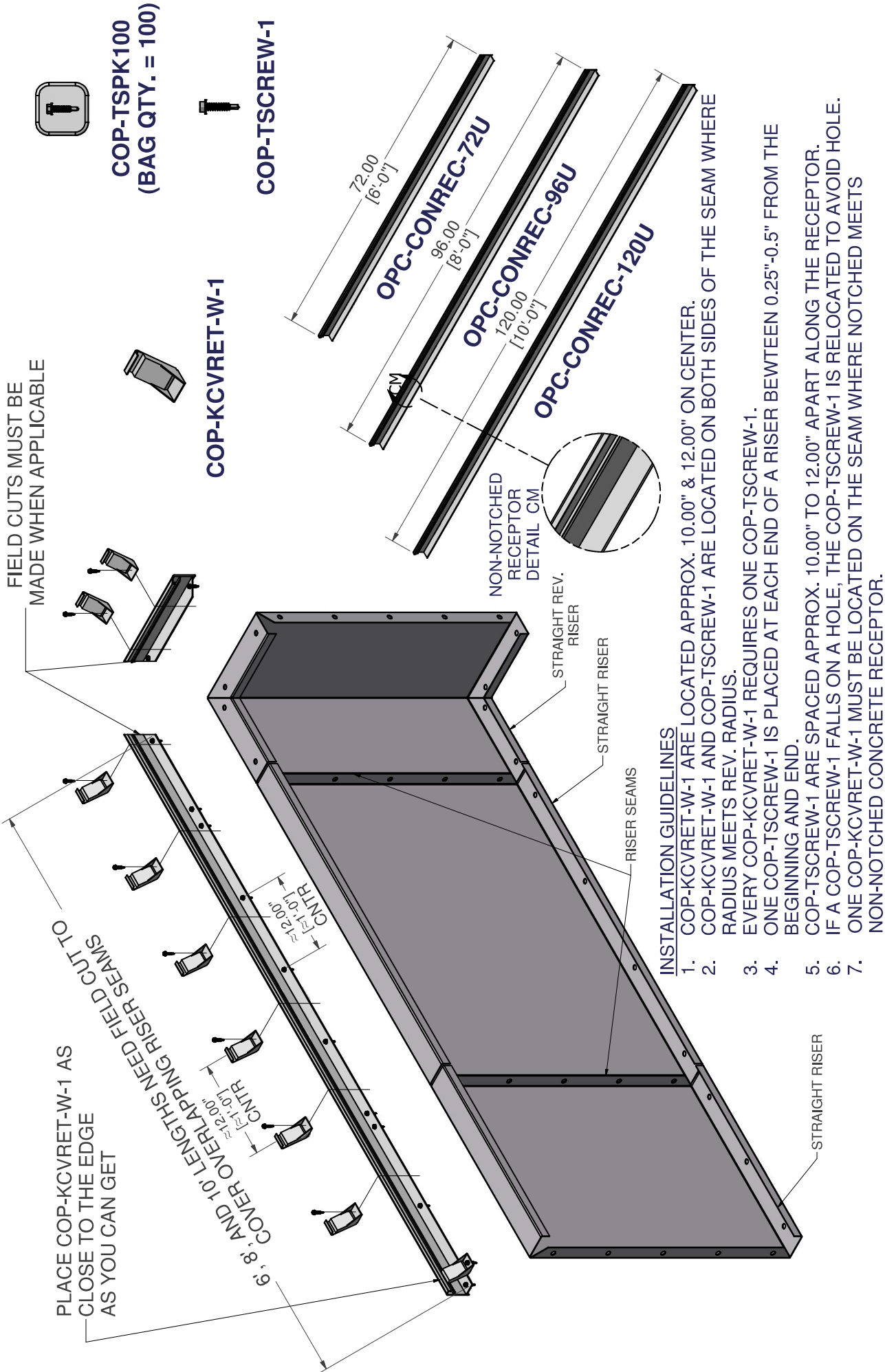

NON-NOTCHED CONCRETE RECEPTOR FIELD INSTALLATION

PARS STRAIGHT CONCRETE RECEPTOR **WEIGHT:** 77.51 lbmass **MACHINE TIME:** N/A **FILE/DIRECTORY:** C:\Vault\FTWDesign\CUSTOM STEPS\ESC-11000-11999\ESC-11271.idw

TOLERANCES EXCEPT AS NOTED	MATERIAL:	DATE: 10/1/2020	NOTES:
0/0 0.0 0.00 0.000 0'	DRAWN BY: SUS	SHEET: 20 OF 21	
±1/8 ±0.25 ±0.0625 ±0.03125 ±1/2"			



INSTALLATION GUIDELINES

1. COP-KCVRET-W-1 ARE LOCATED APPROX. 10.00" & 12.00" ON CENTER.
2. COP-KCVRET-W-1 AND COP-TSCREW-1 ARE LOCATED ON BOTH SIDES OF THE SEAM WHERE RADIUS MEETS REV. RADIUS.
3. EVERY COP-KCVRET-W-1 REQUIRES ONE COP-TSCREW-1.
4. ONE COP-TSCREW-1 IS PLACED AT EACH END OF A RISER BETWEEN 0.25"-0.5" FROM THE BEGINNING AND END.
5. COP-TSCREW-1 ARE SPACED APPROX. 10.00" TO 12.00" APART ALONG THE RECEPTOR.
6. IF A COP-TSCREW-1 FALLS ON A HOLE, THE COP-TSCREW-1 IS RELOCATED TO AVOID HOLE.
7. ONE COP-KCVRET-W-1 MUST BE LOCATED ON THE SEAM WHERE NOTCHED MEETS NON-NOTCHED CONCRETE RECEPTOR.

PLACE COP-KCVRET-W-1 AT SEAMS WHERE STRAIGHT MEETS A RADIUS/REV. RADIUS.

PLACE COP-TSCREW-1 ON BOTH SIDES OF THE SEAMS.

PLACE COP-KCVRET-W-1 AS CLOSE TO THE END EDGE AS YOU CAN GET.

FIELD CUTS MUST BE MADE WHEN APPLICABLE



COP-TSPK100
(BAG QTY. = 100)



COP-TSCREW-1



COP-KCVRET-W-1

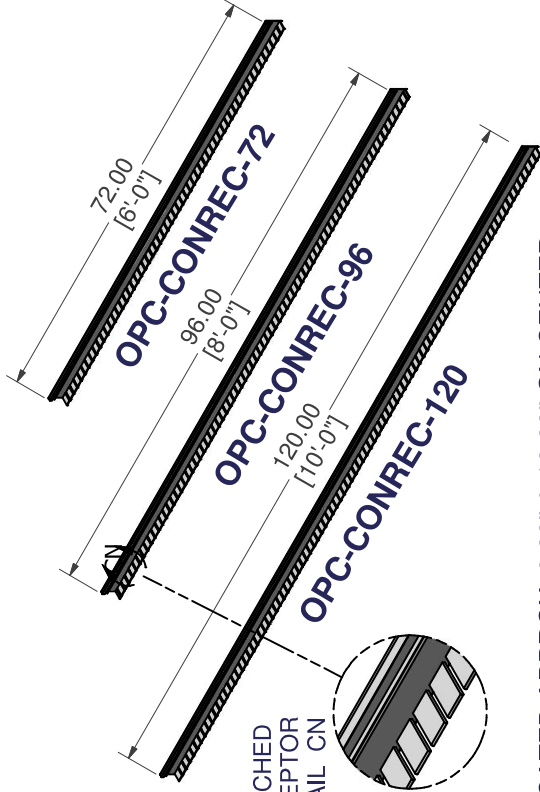

NOTCHED RECEPTOR DETAIL CN

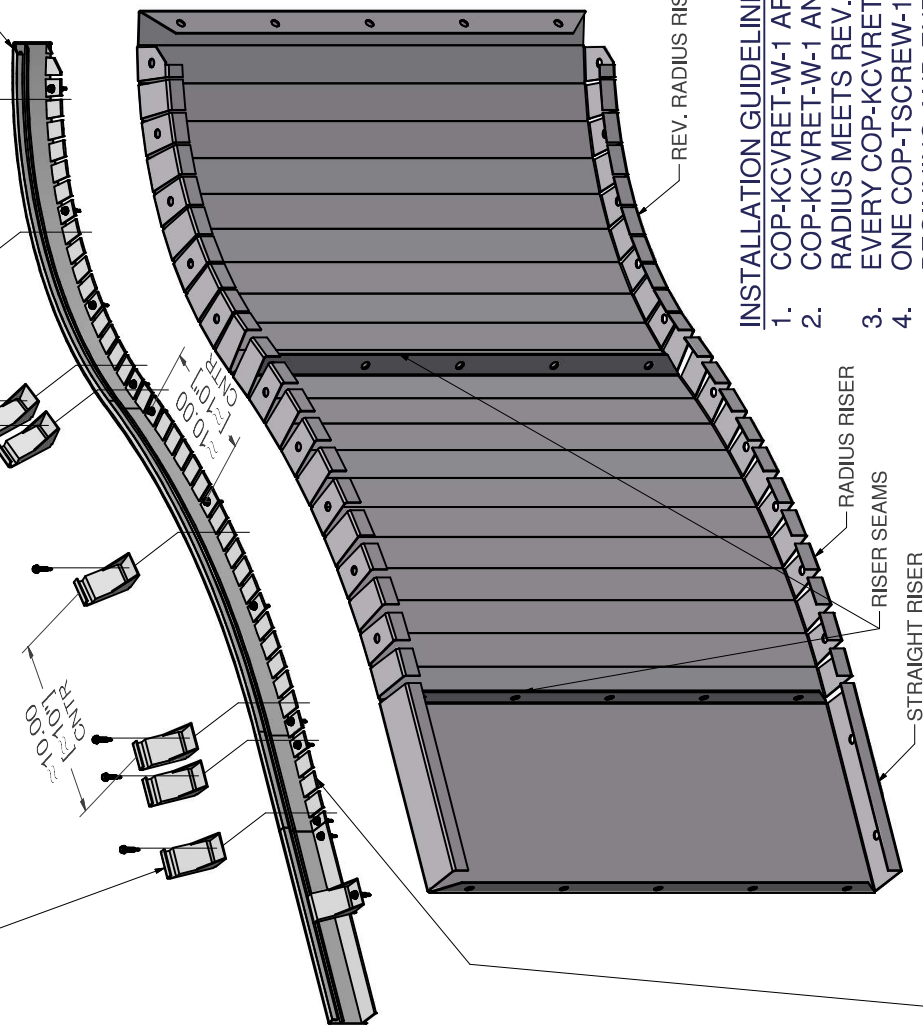
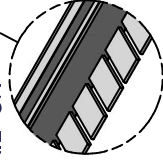

INSTALLATION GUIDELINES

1. COP-KCVRET-W-1 ARE LOCATED APPROX. 8.00" & 10.00" ON CENTER.
2. COP-KCVRET-W-1 AND COP-TSCREW-1 ARE LOCATED ON BOTH SIDES OF THE SEAM WHERE RADIUS MEETS REV. RADIUS.
3. EVERY COP-KCVRET-W-1 REQUIRES ONE COP-TSCREW-1.
4. ONE COP-TSCREW-1 IS PLACED AT EACH END OF A RISER BETWEEN 0.25"-0.5" FROM THE BEGINNING AND END.
5. COP-TSCREW-1 ARE SPACED APPROX. 8.00" TO 10.00" APART ALONG THE RECEPTOR.
6. IF A COP-TSCREW-1 FALLS ON A HOLE, THE COP-TSCREW-1 IS RELOCATED TO AVOID HOLE.
7. ONE COP-KCVRET-W-1 MUST BE LOCATED ON THE SEAM WHERE NOTCHED MEETS NON-NOTCHED CONCRETE RECEPTOR.

ALLOW AN APPROX. OF 6.00" OF OVERLAP GOING FROM RADIUS/REV. RADIUS TO A STRAIGHT RISER.

NOTCHED CONCRETE RECEPTOR FIELD INSTALLATION

PAVE#-RADIUS CONCRETE RECEPTOR

WEIGHT:	52.49 lbmass
TOLERANCES EXCEPT AS NOTED	
0/0 0.0 0.00 0.000 0'	
±1/8 ±0.25 ±0.0625 ±0.03125 ±1/2"	

MACHINE TIME: N/A

FILE/DIRECTORY:

C:\Vault\FTWDesign\CUSTOM STEPS\ESC-11000-11999\ESC-11271.idw



MATERIAL:

DRAWN BY: SUS

DATE: 10/1/2020

SHEET: 21 OF 21

NOTES: